

New Construction Work for:

# Hillcrest Commons

Fort Wayne Housing Authority, Managing Member  
George Guy, Executive Director, FWHA  
7315 Hanna Street, Fort Wayne, IN 46816

Work to be performed at the following locations:

711 East Tillman Road, Fort Wayne, IN 46816

February 7, 2024  
ADDENDUM 1 - March 25, 2024  
ADDENDUM 2 - April 1, 2024  
ADDENDUM 3 - April 16, 2024  
**REVISION 4 - July 19, 2024**



221 W. Baker St.,  
Fort Wayne, IN  
46802  
260.422.7994

[www.martin-riley.com](http://www.martin-riley.com)

SECTION 000105  
CERTIFICATIONS PAGE

**PROJECT:**

HILLCREST COMMONS  
711 EAST TILLMAN ROAD  
FORT WAYNE, INDIANA 46816



**OWNER:**

GEORGE GUY  
FORT WAYNE HOUSING AUTHORITY, MANAGING MEMBER  
7315 SOUTH HANNA STREET  
FORT WAYNE, IN 46816



**ARCHITECT:**

MARTINRILEY ARCHITECTS|ENGINEERS  
221 WEST BAKER STREET  
FORT WAYNE, IN 46802  
PHONE: 260.422.799  
WWW.MARTIN-RILEY.COM



**ELECTRICAL ENGINEERING:**

MARTINRILEY ARCHITECTS|ENGINEERS  
221 WEST BAKER STREET  
FORT WAYNE, IN 46802  
PHONE: 260.422.7994  
WWW.MARTIN-RILEY.COM

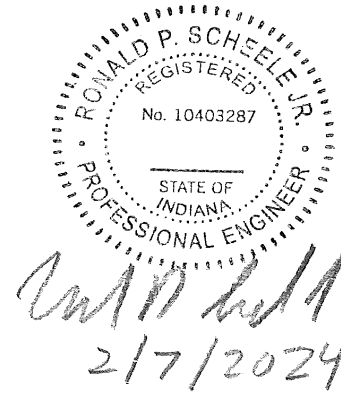

**MECHANICAL ENGINEERING:**

MARTINRILEY ARCHITECTS|ENGINEERS  
221 WEST BAKER STREET  
FORT WAYNE, IN 46802  
PHONE: 260.422.7994  
WWW.MARTIN-RILEY.COM



**CIVIL ENGINEERING:**

MARTINRILEY ARCHITECTS|ENGINEERS  
221 WEST BAKER STREET  
FORT WAYNE, IN 46802  
PHONE: 260.422.7994  
WWW.MARTIN-RILEY.COM

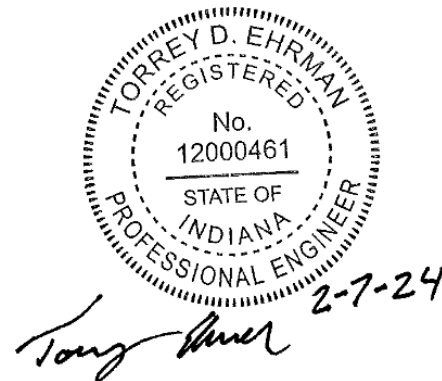

**STRUCTURAL ENGINEERING:**

MARTINRILEY ARCHITECTS|ENGINEERS  
221 WEST BAKER STREET  
FORT WAYNE, IN 46802  
PHONE: 260.422.7994  
WWW.MARTIN-RILEY.COM

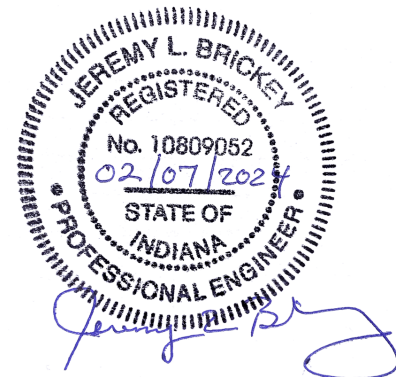

COMMISSION NUMBER: F23066  
DATE OF ISSUE: FEBRUARY 7, 2024

END OF CERTIFICATIONS PAGE

**SECTION 000110  
TABLE OF CONTENTS**

**PROCUREMENT AND CONTRACTING REQUIREMENTS**

**DIVISION 00 -- PROCUREMENT AND CONTRACTING REQUIREMENTS**

- 000101 - Project Title Page
- 000105 - Certifications Page
- 000110 - Table of Contents
- 005000 - Contracting Forms and Supplements
- 005200 - Agreement Form
- 007200 - General Conditions
- 007300 - Supplementary Conditions

**SPECIFICATIONS**

**DIVISION 01 -- GENERAL REQUIREMENTS**

- 012000 - Price and Payment Procedures
- 012300 - Alternates
- 013000 - Administrative Requirements
- 014000 - Quality Requirements
- 015000 - Temporary Facilities and Controls
- 015713 - Temporary Erosion and Sediment Control
- 016000 - Product Requirements
- 016116 - Volatile Organic Compound (VOC) Content Restrictions
- 017000 - Execution and Closeout Requirements
- 017800 - Closeout Submittals

**DIVISION 02 -- EXISTING CONDITIONS**

- 024100 – Demolition

**DIVISION 03 -- CONCRETE**

- 033000 - Cast-in-Place Concrete

**DIVISION 04 -- MASONRY**

- 042000 - Unit Masonry

**DIVISION 05 – METALS**

- 055000 – Metal Fabrications



## **DIVISION 06 -- WOOD, PLASTICS, AND COMPOSITES**

- 061000 - Rough Carpentry
- 061600.16 - Sheathing
- 061753 - Shop-Fabricated Wood Trusses
- 062000 - Finish Carpentry
- 066600 - Cellular PVC Fabrications
- 068316 - Fiberglass Reinforced Paneling

## **DIVISION 07 -- THERMAL AND MOISTURE PROTECTION**

- 071010 - General Roofing Considerations
- 072100 - Thermal Insulation
- 072600 - Vapor Barrier
- 074213.23 - Metal Composite Material Wall Panels
- 074616 - Aluminum Siding
- 074646 - Fiber Cement Siding
- 075400 - Thermoplastic Membrane Roofing
- 076200 - Sheet Metal Flashing and Trim
- 077100 - Roof Specialties
- 078400 - Firestopping
- 079200 - Joint Sealants

## **DIVISION 08 -- OPENINGS**

- 081113 - Hollow Metal Doors and Frames
- 081416 - Flush Wood Doors
- 084313 - Aluminum Framed Storefronts
- 085413 - Fiberglass Windows
- 087100 - Door Hardware
- 088000 - Glazing
- 088300 - Mirrors

## **DIVISION 09 -- FINISHES**

- 092116 - Gypsum Board Assemblies
- 096500 - Resilient Flooring
- 096813 - Tile Carpeting
- 099113 - Exterior Painting
- 099123 - Interior Painting

## **DIVISION 10 -- SPECIALTIES**

- 101400 - Signage
- 102600 - Wall and Door Protection
- 105500 - Postal Specialties

105723 - Closet and Utility Shelving

**DIVISION 11 -- EQUIPMENT**

113013 - Residential Appliances

**DIVISION 12 -- FURNISHINGS**

122113 - Horizontal Louver Blinds

123530 - Residential Casework

123600 - Countertops

**DIVISION 14 -- CONVEYING EQUIPMENT**

142123 - Electric Traction Passenger Elevator

**DIVISION 22 -- PLUMBING**

220516 - Expansion Fittings and Loops for Plumbing Piping

220529 - Hangers and Supports for Plumbing Piping and Equipment

220716 - Plumbing Equipment Insulation

220719 - Plumbing Piping Insulation

221005 - Plumbing Piping

221006 - Plumbing Piping Specialties

221429 - Sump Pumps

223000 - Plumbing Equipment

224000 - Plumbing Fixtures

**DIVISION 23 -- HEATING, VENTILATING, AND AIR-CONDITIONING (HVAC)**

230529 - Hangers and Supports for HVAC Piping and Equipment

230593 - Testing, Adjusting, and Balancing for HVAC

230713 - Duct Insulation

230716 - HVAC Equipment Insulation

230719 - HVAC Piping Insulation

232300 - Refrigerant Piping

233100 - HVAC Ducts and Casings

233423 - HVAC Power Ventilators

233700 - Air Outlets and Inlets

238126.13 - Small-Capacity Split-System Air Conditioners

238200 - Convection Heating and Cooling Units

**DIVISION 26 -- ELECTRICAL**

260519 - Low-Voltage Electrical Power Conductors and Cables

260526 - Grounding and Bonding for Electrical Systems

260529 - Hangers and Supports for Electrical Systems

260533.13 - Conduit for Electrical Systems  
260533.16 - Boxes for Electrical Systems  
260553 - Identification for Electrical Systems  
260583 - Wiring Connections  
260923 - Lighting Control Devices  
262416 - Panelboards  
262726 - Wiring Devices - Lutron  
265100 - Interior Lighting  
265600 - Exterior Lighting

**DIVISION 27 -- COMMUNICATIONS**

271000 – Structured Cabling

**DIVISION 28 -- ELECTRONIC SAFETY AND SECURITY**

282000 - Video Surveillance  
284600 - Fire Detection and Alarm

**DIVISION 31 -- EARTHWORK**

311000 - Site Clearing  
312200 - Grading  
312316 - Excavation  
312323 - Fill

**DIVISION 32 -- EXTERIOR IMPROVEMENTS**

321216 - Asphalt Paving  
321313 - Concrete Paving  
321623 - Sidewalks  
329219 - Seeding

**DIVISION 33 -- UTILITIES**

330561 - Concrete Manholes  
331416 - Site Water Utility Distribution Piping  
333113 - Site Sanitary Sewerage Gravity Piping  
334211 - Stormwater Gravity Piping

**END OF SECTION**

**SECTION 002213  
SUPPLEMENTARY INSTRUCTIONS TO BIDDERS**

**GENERAL**

**AIA DOCUMENT A701, "INSTRUCTIONS TO BIDDERS - CURRENT EDITION", ARTICLES 1 THROUGH 8, AS PUBLISHED BY THE AMERICAN INSTITUTE OF ARCHITECTS, 1735 NEW YORK AVENUE, N.W., WASHINGTON, D.C. 20006 ARE HEREBY, EXCEPT AS MAY BE INCONSISTENT HEREWITH, MADE PART OF THESE BIDDING DOCUMENTS. THESE INSTRUCTIONS TO BIDDERS APPLY EQUALLY TO AND ARE PART OF ALL BIDDING DOCUMENTS BETWEEN THE OWNER AND EACH SEPARATE CONTRACTOR FOR THE WORK UNDER THIS PROJECT.**

**SUPPLEMENTARY INSTRUCTIONS TO BIDDERS:**

**THE FOLLOWING SUPPLEMENTS MODIFY, CHANGE, DELETE FROM OR ADD TO THE "INSTRUCTIONS TO BIDDERS - CURRENT EDITION", AIA DOCUMENT A701. WHERE ANY ARTICLE OF THE INSTRUCTIONS TO BIDDERS IS MODIFIED OR ANY PARAGRAPH, SUBPARAGRAPH OR CLAUSE THEREOF IS MODIFIED OR DELETED BY THESE SUPPLEMENTS, THE UNALTERED PROVISIONS OF THAT ARTICLE, PARAGRAPH, SUBPARAGRAPH, OR CLAUSE SHALL REMAIN IN EFFECT.**

**ARTICLE 1 DEFINITIONS**

**1.6, REVISE THE PARAGRAPH TO READ AS FOLLOWS:**

1.6 An Alternate Bid (or Alternate) is an amount stated in the Bid to be added to or deducted from the amount of the Base Bid if the corresponding change in the Work, as described in the Bidding Documents, is accepted. Alternates are identified in the Contract Documents.

**1.6.1, ADD THE FOLLOWING NEW SUBPARAGRAPH:**

1.6.1 A Voluntary Alternate Bid (or Voluntary Alternate) is an amount proposed by the Bidder as alternative materials, products, or equipment not described in the Bidding Documents or otherwise approved as a substitution as identified under paragraph 3.3 Substitutions. Bids proposed in this manner are to be clearly identified as amounts to be added to, deducted from, or in lieu of the Base Bid or Alternate Bids described in the Bidding Documents. Voluntary Alternates shall be subject to the criteria of paragraph 3.3. Substitutions, before it will be considered or accepted. The Architect's decision of acceptance or non-acceptance of a proposed Voluntary Alternate shall be final.

**1.10, ADD THE FOLLOWING PARAGRAPH:**

1.10 The Owner is Fort Wayne Housing Authority, 7315 Hanna Street, Fort Wayne, Indiana, 54812.

**1.11, ADD THE FOLLOWING PARAGRAPH:**

1.11 The Architect is:  
MartinRiley architects|engineers  
221 West Baker Street; Fort Wayne, Indiana 46802  
Phone: (260) 422-7994

**ARTICLE 2 BIDDER'S REPRESENTATIONS**

**2.1.7, ADD THE FOLLOWING PARAGRAPH:**

2.1.7 No Bidder, after the award of the Contract, shall be allowed any extra compensation for reasons of their failure to inform themselves fully, prior to bidding, of all requirements of the Contract Documents, drawings, specifications and circumstances of the building site.

**2.1.8, ADD THE FOLLOWING PARAGRAPH:**

2.1.8 Bidders represent that at the time Bids are submitted for consideration, they have no questions regarding ambiguity or omissions and are submitting Bids that will result in a complete project.

## **ARTICLE 3 BIDDING DOCUMENTS**

### **3.1.1.1, ADD THE FOLLOWING SUBPARAGRAPH:**

3.1.1.1 Bidding documents may be obtained from the Architect in PDF format.

### **3.2.1.1, ADD THE FOLLOWING SUBPARAGRAPH:**

3.2.1.1 In the event of an inconsistency between the Drawings and the Specifications or within either Document that is not clarified by addenda, the better quality or greater quantity of Work shall be provided in accordance with the Architect's interpretation.

### **3.2.4, ADD THE FOLLOWING NEW SUBPARAGRAPH:**

3.2.4 Questions for this project shall be directed to:

Project Manager: Paul Konwinski

Phone: (260) 422-7994

email: pkonwinski@martin-riley.com

1. Structural Engineer: Jeremy Brickey

Phone: (260) 422-7994

email: jbrickey@martin-riley.com

2. Mechanical Engineer: Jeff Neumann

Phone: (260) 422-7994

3. Electrical Engineer: Ron Scheele

Phone: (260) 422-7994

email: rscheele@martin-riley.com

4. Civil Engineer: Torrey Ehrman

Phone: (260) 422-7994

1) email: tehrman@martin-riley.com

5. When unable to reach specific contact person, address questions to the Project Manager.

### **3.3.1.1, ADD THE FOLLOWING SUBPARAGRAPH:**

3.3.1.1 Where specific materials, trade names, or models of certain manufacturers are specified, it is done to establish a basis of durability, efficiency, appearance and simplification of maintenance, and not for the purpose of limiting competition. If a bidder wishes to use a different product in the bid to be submitted, then that product must be submitted for approval following the submittal procedures defined elsewhere within this specification. The decision of the Architect and Owner shall be final.

### **3.3.2, ADD THE FOLLOWING AFTER "ARCHITECT'S" IN THE LAST LINE:**

"...and Owner's..."

## **ARTICLE 4 BIDDING PROCEDURES**

### **4.1.2.1, ADD THE FOLLOWING SUBPARAGRAPH:**

4.1.2.1 Failure to bid requested alternates, unit prices or fill in any blanks will be considered justification for rejection of the bid.

### **4.1.8, ADD THE FOLLOWING NEW PARAGRAPH:**

4.1.8 Proposals will be "STIPULATED SUM" for the projects as listed in Division 1, GENERAL REQUIREMENTS and in the Proposal Form Supplement.

### **4.3.5, ADD THE FOLLOWING NEW SUBPARAGRAPH:**

4.3.5 Deliver copies of the bid and any other documents required in duplicate on or before the time and at the location specified.

## **ARTICLE 5 CONSIDERATION OF BIDS**

### **5.1.2, ADD THE FOLLOWING PARAGRAPH**

5.1.2 The Owner reserves the right to waive any and all formalities.

**5.2, MODIFY THE FIRST SENTENCE TO READ:**

The Owner reserves the right to reject any or all Bids and is not obligated to accept the lowest or any combination of Bids.

**ARTICLE 7 PERFORMANCE BOND AND PAYMENT BOND**

**7.1.1, MODIFY THE FIRST SENTENCE TO READ:**

7.1.1 The Bidder shall furnish bonds, i.e, Performance Bond and Payment Bond covering the faithful performance of the Contract and payment of all obligations arising thereunder, in an amount specified in the General and Supplementary Conditions of the Contract.

**END OF SECTION**

**SECTION 005000  
CONTRACTING FORMS AND SUPPLEMENTS**

**PART 1 GENERAL**

**1.01 AGREEMENT AND CONDITIONS OF THE CONTRACT**

- A. See Section 00 7300 for the Supplementary Conditions.
- B. The Agreement is based on AIA A101.
- C. The General Conditions are based on AIA A201.

**1.02 FORMS**

- A. Use the following forms for the specified purposes unless otherwise indicated elsewhere in Contract Documents.
- B. Bond Forms:
  - 1. Performance and Payment Bond Form: AIA A312.
- C. Post-Award Certificates and Other Forms:
  - 1. Schedule of Values Form: AIA G703.
  - 2. Application for Payment Forms: AIA G702 with AIA G703 (for Contractors).
- D. Clarification and Modification Forms:
  - 1. Architect's Supplemental Instructions Form: AIA G710.
  - 2. Construction Change Directive Form: AIA G714.
  - 3. Change Order Form: AIA G701.
- E. Closeout Forms:
  - 1. Certificate of Substantial Completion Form: AIA G704.

**1.03 REFERENCE STANDARDS**

- A. AIA A101 - Standard Form of Agreement Between Owner and Contractor where the basis of Payment is a Stipulated Sum; 2017.
- B. AIA A201 - General Conditions of the Contract for Construction; 2017.
- C. AIA A312 - Performance Bond and Payment Bond; 2010.
- D. AIA G701 - Change Order; 2017.
- E. AIA G702 - Application and Certificate for Payment; 1992.
- F. AIA G703 - Continuation Sheet; 1992.
- G. AIA G704 - Certificate of Substantial Completion; 2017.
- H. AIA G710 - Architect's Supplemental Instructions; 2017.
- I. AIA G714 - Construction Change Directive; 2017.

**PART 2 PRODUCTS - NOT USED**

**PART 3 EXECUTION - NOT USED**

**END OF SECTION**

**SECTION 005200  
AGREEMENT FORM**

**PART 1 GENERAL**

**1.01 FORM OF AGREEMENT**

- A. AIA Document A101, Owner-Contractor Agreement Form - Stipulated Sum, current edition, forms the basis of Contract between the Owner and Contractor.
- B. Copies of the Owner-Contractor Agreement Form - Stipulated Sum, AIA Document A101, are available from the Architect.
- C. The Insurance and Bonds Exhibit A that is part of this agreement, between the Owner and the Contractor is attached following this page.
  - 1. 100% Performance Bond
  - 2. 100% Payment Bond

**1.02 RELATED REQUIREMENTS**

- A. Section 007200 - General Conditions.
- B. Section 00 7300 - Supplementary Conditions.

**PART 2 PRODUCTS (NOT USED)**

**PART 3 EXECUTION (NOT USED)**

**END OF SECTION**



**SECTION 007200  
GENERAL CONDITIONS**

**PART 1 FORM OF GENERAL CONDITIONS**

**1.01 THE GENERAL CONDITIONS APPLICABLE TO THIS CONTRACT ARE INCORPORATED INTO THE PROJECT MANUAL BY REFERENCE, AND ARE A PART OF THE DOCUMENTS AS MUCH AS IF THEY HAD BEEN REPRINTED IN THEIR ENTIRETY.**

- A. AIA Document A201, current edition, "General Conditions of the Contract for Construction", Articles 1 through 15, as published by The American Institute of Architects, 1735 New York Avenue, N.W., Washington, D.C. 20006 are hereby, except as may be inconsistent herewith, made part of these Contract Documents.
- B. Copies of the General Conditions, AIA Document A201, are available from the Architect.

**1.02 RELATED REQUIREMENTS**

- A. Section 00 7300 - Supplementary Conditions.

**END OF SECTION**

**SECTION 007300  
SUPPLEMENTARY CONDITIONS**

**GENERAL**

**SUMMARY**

**THESE SUPPLEMENTARY CONDITIONS AMEND AND SUPPLEMENT THE "GENERAL CONDITIONS OF THE CONTRACT FOR CONSTRUCTION" AND OTHER PROVISIONS OF THE CONTRACT DOCUMENTS AS INDICATED BELOW. WHERE ANY ARTICLE OF THE GENERAL CONDITIONS IS MODIFIED OR ANY PARAGRAPH, SUBPARAGRAPH OR CLAUSE THEREOF IS MODIFIED OR DELETED BY THESE SUPPLEMENTS, THE UNALTERED PROVISIONS OF THAT ARTICLE, PARAGRAPH, SUBPARAGRAPH, OR CLAUSE SHALL REMAIN IN FULL FORCE AND EFFECT.**

**THE TERMS USED IN THESE SUPPLEMENTARY CONDITIONS THAT ARE DEFINED IN THE GENERAL CONDITIONS HAVE THE MEANINGS ASSIGNED TO THEM IN THE GENERAL CONDITIONS.**

**ARTICLE 1 GENERAL PROVISIONS**

**1.2.1, ADD THE FOLLOWING SENTENCE:**

In the case of an inconsistency between Drawings and Specifications or within either Document not clarified by addendum, the better quality or greater quantity of Work shall be provided in accordance with the Architect's interpretation.

**1.7, ADD THE FOLLOWING PARAGRAPH:**

1.7.1, The Architect may, with the concurrence of the Owner, furnish to the Contractor versions of Instruments of Service in electronic form. The Contract Documents executed or identified in accordance with Section 1.5.1 shall prevail in case of an inconsistency with subsequent versions made through electronic means involving computers.

**1.7, ADD THE FOLLOWING PARAGRAPH:**

1.7.2, The Contractor shall not transfer or reuse Instruments of Service in electronic or machine readable form without the prior written consent of the Architect.

**ARTICLE 3 CONTRACTOR**

**3.1.1, ADD THE FOLLOWING SUBPARAGRAPH:**

3.1.1.1, The Contractor should be in the business and regularly engaged in the type of construction as outlined in the Contract Documents and as specified herein for a minimum period of five (5) years and be properly licensed in the jurisdiction where the Project is constructed.

**3.2.2, ADD THE FOLLOWING SUBPARAGRAPH:**

3.2.2.1, The Contractor shall completely review the Contract Documents for errors, omissions or inconsistencies no later than 15 days prior to the commencement of Work or 3 days prior to the Pre-Construction meeting and submit written requests for clarification.

**3.4.2, ADD THE FOLLOWING SUBPARAGRAPHS:**

3.4.2.1, After receipt of notice of contract award, the Owner and the Architect will consider a formal request for the substitution of products in place of those specified.

3.4.2.2, By making requests for substitutions based on Subparagraph 3.4.2 above, the Contractor:

- .1 Represents that the Contractor has personally investigated the proposed substitute product and determined that it is equal or superior in all respects to that specified;
- .2 Represents that the Contractor will provide the same warranty for the substitution that the Contractor would for that specified
- .3 Certifies that the cost data presented is complete and includes all related costs under this Contract except the Architect's redesign costs, and waives all claims for additional costs related to the substitution which subsequently become apparent; and

.4 Will coordinate the installation of the accepted substitute, making such changes as may be required for the Work to be complete in all respects.

.5 Will be responsible for additional costs of the Architect required to redesign, or issue modified documents.

**3.6, ADD THE FOLLOWING PARAGRAPH:**

3.6.1, The Owner is Indiana Sales Tax exempt. The Owner's exemption number shall be provided to the Contractor for use for the work, subject to the Owner's limitations.

**3.9.1, CHANGE TO READ AS FOLLOWS:**

The Contractor shall employ a competent superintendent and necessary assistants who shall be in attendance at the project site during the performance of the Work until substantial completion, and for such additional time thereafter as the Architect may determine to be necessary for the expeditious completion of the Work. The Contractor shall not reassign or remove the superintendent to other projects prior to Substantial Completion. The superintendent shall represent the Contractor, and communications given to the superintendent shall be as binding as if given to the Contractor. Important communications shall be confirmed in writing. Other communications shall be similarly confirmed on written request in each case. The Contractor shall remove the superintendent if requested to do so in writing by the Owner, and shall promptly replace him with a competent person reasonably acceptable to the Owner.

**3.12.5, ADD THE FOLLOWING:**

Shop Drawings, Product Data, Samples and other similar submittals which, by their markings and notations placed on them by the Contractor, do not graphically demonstrate his/her understanding of the elements or materials inclusion into the Work shall be returned without action or further comment.

**3.13, ADD THE FOLLOWING PARAGRAPH:**

3.13.1, The Contractor shall abide by the rules of the Owner regarding the use of the premises and will confine activities to the areas designated.

**3.14, ADD THE FOLLOWING PARAGRAPH:**

3.14.3, Cutting and patching shall be done by the construction trades whose work is being cut or patched, irrespective of the Contractor responsible for or requiring the cutting and patching work.

**ARTICLE 5 SUBCONTRACTORS**

**5.2.1, CHANGE THE FIRST SENTENCE TO READ AS FOLLOWS:**

Unless otherwise stated in the Contract Documents or the bidding requirements, the Contractor, no later than 24 hours after the receipt of notice of contract award, shall furnish in writing to the Owner through the Architect the names of persons or entities (including those who are to furnish materials or equipment fabricated to a special design) proposed for each principal portion of the Work.

**5.2, ADD THE FOLLOWING NEW PARAGRAPH:**

5.2.5, Financial irresponsibility as determined by Owner and past record of failure to perform work on schedule shall be a valid reason for a reasonable objection to any such person or entity.

**ARTICLE 7 CHANGES IN THE WORK**

**7.2.1.3, ADD, THE FOLLOWING SUBPARAGRAPHS:**

7.2.1.3.1, Methods used in determining adjustments to the Contract Sum shall be as follows:

.1 15 percent overhead and profit on the net cost of Work done by the Contractor;

.2 5 percent overhead and profit on the cost of Work done by any Subcontractor;

.3 On Work deleted from the Contract, credit to the Owner shall be the Architect approved net cost plus 1/2 of the overhead and profit percentage noted above.

## **ARTICLE 9 PAYMENTS AND COMPLETION,**

### **9.2, ADD THE FOLLOWING PARAGRAPH:**

9.2.1, The Contractor's submitted schedule of values shall include base bid items, accepted alternates and all overhead and profit. These items shall be listed separately. Contract contingency amounts and/or allowances shall be listed on their own separate lines.

### **9.3.1, ADD THE FOLLOWING SENTENCES:**

The Application for Payment shall be submitted in triplicate, unless otherwise indicated in the Contract Documents. The form of Application for Payment shall be a notarized original AIA Document G702, Application and Certificate for Payment, supported by AIA Document G703, Continuation Sheet. Copies may be made of completed Documents, but use of illegal photocopies of AIA Documents shall be cause for rejection of the Application.

### **9.3.1, ADD THE FOLLOWING SUBPARAGRAPHS:**

9.3.1.3, Until final payment, the Owner shall pay 90 percent of the amount due the Contractor on account of each progress payment for Work completed and material delivered and stored at the site but not incorporated into the Work. For each Work category shown to be 50 percent or more complete in the Application for Payment, without reduction of previous retainage, the Contractor may request that no further retainage be withheld from future progress payments. If such request is approved and the manner of completion of the Work and its progress are to remain satisfactory to the Owner and the Architect, and in the absence of good and sufficient reason, the Architect will on the presentation of the Contractor of consent of surety, if any, authorize any remaining progress payments to be paid in full.

9.3.1.4, If upon Substantial Completion of the Work there are any remaining uncompleted items, the Owner shall withhold, until those items are completed, an amount equal to up to three hundred percent (300%) of the value of each item as determined by the Architect or Owner.

### **9.8.3, ADD THE FOLLOWING SUBPARAGRAPH:**

9.8.3.1, Except with the consent of the Owner, the Architect will perform no more than two (2) final observation(s) to determine whether the Work or a designated portion thereof has attained Substantial Completion in accordance with the Contract Documents. The Owner shall be entitled to deduct from the Contract Sum amounts paid to the Architect for any additional observations.

### **9.8.5, DELETE THE SECOND SENTENCE AND SUBSTITUTE WITH THE FOLLOWING:**

Upon such acceptance and consent of surety, if any, the Owner shall make payment sufficient to increase the total payments to 100 percent of the Contract Sum, less such amounts as the Architect shall determine for incomplete Work and unsettled claims.

### **9.10.1, ADD THE FOLLOWING SUBPARAGRAPH:**

9.10.1.1, Except with the consent of the Owner, the Architect will perform no more than one attempt(s) to determine whether the Work or a designated portion thereof has attained Final Completion in accordance with the Contract Documents. The Owner shall be entitled to deduct from the Contract Sum amounts paid to the Architect for any additional observations.

## **ARTICLE 10 PROTECTION OF PERSONS AND PROPERTY**

### **10.2.4, ADD THE FOLLOWING SUBPARAGRAPH:**

10.2.4.1, When use or storage of explosives or other hazardous materials or equipment or unusual methods are necessary, the Contractor shall give the Owner reasonable advance notice.

### **10.3.4, ADD THE FOLLOWING SUBPARAGRAPH:**

10.3.4.1, The Contractor warrants to the Owner and Architect that no materials containing asbestos or polychlorinated biphenyl (PCB) will be permitted in the Project or under the contract. Each contractor shall furnish to the Owner and Architect a sworn affidavit stating that materials used under this contract did not contain asbestos or polychlorinated biphenyl (PCB)

upon completion of the project.

## **ARTICLE 11 INSURANCE AND BONDS**

### **11.1.1, ADD THE FOLLOWING AFTER "COMPANIES" IN LINE 1:**

". . . companies rated A+ or A by Best Insurance Reports and . . ."

### **11.1.1, ADD THE FOLLOWING SUBPARAGRAPH**

11.1.1.1, General Liability coverages on a claims-made basis shall not be acceptable.

### **11.1.2, CHANGE THE PARAGRAPH TO READ AS FOLLOWS:**

The insurance required by subparagraph 11.1.1 shall be written for not less than limits of liability specified in the Contract Documents or required by law, whichever coverage is greater. Coverage shall be written on an occurrence basis and shall be maintained without interruption from date of commencement of the Work until date of final payment and termination of any coverage required to be maintained after final payment and, with respect to the Contractor's completed operations coverage, until the expiration of the period for correction of Work or for such other period for maintenance of completed operations coverage as specified in the Contract Documents. The insurance required shall cover, but not limited to the following:

1. Premises Operations (deleting x, c, or u exclusions).
2. Owner's and Contractors' Protective.
3. Products and Completed Operations.
4. Personal injury Liability with Employment Exclusion deleted.
5. Contractual, including specified provision for Contractor's obligation under Paragraph 3.18.
6. Owner, non-owned and hired motor vehicles.
7. Broad Form Property Damage including Completed Operations.
8. Cancellation Notice to Owner - 30 days.
9. Owner shall be named as an "Additional Insured" under Contractors Liability Policies.

### **11.1.2, ADD THE FOLLOWING SUBPARAGRAPH:**

11.1.2.1, The contractor shall maintain such insurance as will protect them from claims under Workman's Compensation Acts, other employee benefit acts, claims for damages because of bodily injury including death to their employees and all other, and claims from damage to property any or all which may arise both out of and during operations under this contract, whether such operations be by them or by any subcontractor or sub-subcontractor or anyone directly or indirectly employed by either of them. This insurance shall be written for and not less than the minimum limits of liability specified as follows:

Workers' Compensation and Employers Liability:

State: Statutory

Applicable Federal: Statutory

Liability:

\$1,000,000 Per Accident

Comprehensive or Commercial General Liability:

Bodily Injury:

\$1,000,000 Each Occurrence

\$1,000,000 Aggregate

Property Damage:

\$1,000,000 Each Occurrence

\$1,000,000 Aggregate

Comprehensive Automobile Liability (including owned, non-owned and hired vehicles):

Bodily Injury:

\$1,000,000 Each Person

\$1,000,000 Each Occurrence

Property Damage:

\$1,000,000 Each Occurrence

Umbrella Excess Liability (this amount is over Primary Insurance)

\$4,000,000 Each Occurrence

**11.1.3, ADD THE FOLLOWING SUBPARAGRAPH:**

11.1.3.1, Furnish one copy of the certificate for each copy of the Owner-Contractor Agreement. Specifically set forth evidence of all insurance required of the Contractor by this Article 11. The form of the certificate shall be ACORD Form 25-S current edition. Furnish copies of any endorsements that are subsequently issued amending coverage or limits.

**11.3.1.1, DELETE THE SUBPARAGRAPH, AND REPLACE WITH THE FOLLOWING:**

Property Insurance shall be on an all-risk policy form. Coverage under an all-risk policy shall be in an amount not less than one-hundred (100) percent of the insurable replacement value of the structure including materials, equipment and supplies of all kinds destined to become a permanent part of said structure, while on job site. All-risk coverage shall include, but not necessarily be limited to, coverage for all perils of fire (with extended coverage) and physical loss or damage including, without duplication of coverage, theft, vandalism, civil commotion, riot, malicious mischief, collapse, earthquake, flood, water damage, lightning, hail, windstorm, explosion, smoke, vehicles, aircraft, falsework, testing and startup, temporary buildings and debris removal including demolition occasioned by enforcement of any applicable legal requirements, and shall cover reasonable compensation for Architect's and Contractor's services and expenses required as a result of such insured loss. Coverage for all perils shall be subject to those limitations specified under the terms of the standard policy in effect. Loss which is covered under the all-risk property policy shall be subject to a deductible of five hundred dollars (\$10,000.00) per occurrence for the perils of theft and vandalism.

**11.3.1.3, SUBSTITUTE SUBPARAGRAPH WITH THE FOLLOWING.**

If the property insurance requires deductibles, the Contractor shall pay \$10,000.00 of the deductible per occurrence.

**11.3.1.4, SUBSTITUTE SUBPARAGRAPH WITH THE FOLLOWING.**

The Contractor shall be responsible for the coverage of materials stored off the site and the portions of work in transit.

**11.3.1, ADD THE FOLLOWING SUBPARAGRAPH:**

11.3.1.6, The Contractor shall make such provisions as necessary to replace items of his work missing by theft prior to acceptance of his work by the Owner.

**11.3.2, DELETE THE PARAGRAPH, AND REPLACE WITH THE FOLLOWING:**

The Owner shall purchase and maintain such boiler and machinery insurance as may be required by the Contract Documents or by law. This insurance shall include the interests of the Owner, the Contractor, Subcontractors and Sub-subcontractors in the work.

**11.3.9, DELETE THE THIRD SENTENCE.**

**11.3.10, DELETE PARAGRAPH, AND REPLACE WITH THE FOLLOWING:**

The Owner as fiduciary shall have power to adjust and settle a loss with the insurer unless one of the parties with interest shall object in writing within five days after of loss.

**11.4.1, DELETE PARAGRAPH, AND REPLACE WITH THE FOLLOWING:**

The Contractor shall furnish bonds covering faithful performance of the Contract and Payment of obligations arising thereunder. Bonds are to be provided by and underwritten by a bonding company that is rated A or A+ by Best Insurance Report. The cost of the bonds is to be included in the Contract Sum. The amount of each bond shall be equal to one-hundred percent (100%) of the Contract Sum.

**11.4.1, ADD THE FOLLOWING SUBPARAGRAPH:**

11.4.1.1, The Contractor shall deliver the required bonds to the Owner before the date the Agreement is entered into, or if the Work is to be commenced prior thereto in response to a letter of intent, the Contractor shall, prior to the commencement of the Work, submit evidence satisfactory to the Owner that such bonds will be furnished.

**11.4.1, ADD THE FOLLOWING SUBPARAGRAPH:**

11.4.1.2, The Contractor shall require the attorney-in-fact who executes the required bonds on behalf of the surety to affix thereto a certified and current copy of the power of attorney.

**ARTICLE 13 MISCELLANEOUS PROVISIONS**

**13.4.1, DELETE THE LAST SENTENCE, AND REPLACE WITH THE FOLLOWING:**

The Contractor shall bear all costs for tests, inspections, approvals, and performance testing as required in the Contract Documents unless otherwise noted, or where building codes or applicable laws or regulations prohibit the Owner from delegating their costs to the Contractor.

**13.5. DELETE PARAGRAPH IN ITS ENTIRETY.**

**13, ADD THE FOLLOWING PARAGRAPH AND SUBPARAGRAPHS:**

**13.6, EQUAL OPPORTUNITY**

13.6.1, The Contractor shall maintain policies of employment as follows:

13.6.1.1 The Contractor and the Contractor's Subcontractors shall not discriminate against any employee or applicant for employment because of race, religion, color, sex, or national origin. The Contractor shall take affirmative action to insure that applicants are employed, and that employees are treated during employment without regard to their race, religion, color, sex or national origin. Such action shall include, but not be limited to, the following: employment, upgrading, demotion, or transfer; recruitment or recruitment advertising; layoff or termination; rates of pay or other forms of compensation; and selection for training, including apprenticeship. The Contractor agrees to post in conspicuous places, available to employees and applicant for employment, notices setting forth the policies of nondiscrimination.

13.6.1.2 The Contractor and the Contractor's Subcontractors shall, in all solicitation or advertisements for employees placed by them or on their behalf, state that all qualified applicants will receive consideration for employment without regard to race, religion, color, sex or national origin.

**ADD THE FOLLOWING ARTICLE AND THE FOLLOWING PARAGRAPHS AND SUBPARAGRAPHS:**

**ARTICLE 16 DRAWINGS AND SPECIFICATIONS**

**16.1, Specifications:**

16.1.1, Specifications are organized into Divisions and Sections to facilitate presentation of the information in a systematic manner, based on Industry standards (CSI Masterformat). Such separation shall not operate to make the Architect an arbiter to establish limits of subcontracts between Contractor and Subcontractor, nor shall these separations in any way indicate that the Architect has established that responsibility for any portion of the work is assigned to a particular trade or subcontractor.

16.1.2 Trade, brand or manufacturer's names when specified or noted are used to establish a standard of quality, durability, appearance and efficiency. Substitutions may be made only for reasons that original materials cannot be supplied due to conditions beyond control of the Contractor, or because delivery cannot be made in time to be incorporated into progress of work.

16.1.3 Such substitutions shall be made only after bona fide quotations and delivery schedule for both original item and substitute material is ordered. Contractor shall supply for Architect's consideration samples, product data, and exact amount of credit or extra costs involved in proposed substitution if accepted.

16.1.4 Specifications are in abbreviated form and may include incomplete sentences. Omissions of words or phrases such as "The Contractor shall", "in conformity therewith", "shall be", "as noted on the drawings", and "an" are intentional. Supply omitted words or phrases by inference.

**16.2 Drawings**

16.2.1, Drawings are organized by design discipline. The Contractor and Sub-Contractors are required to review the entire set of Documents to ascertain the full extent of the work

required to complete the Project. The presentation of information and organization of the Drawings shall not serve to make the Architect an arbiter to establish limits of subcontracts between Contractor and Subcontractor, nor shall these separations in any way indicate that the Architect has established that responsibility for any portion of the work is assigned to a particular trade or subcontractor.

16.3 Manufacturers' Directions

16.3.1, All manufactured articles, materials, and equipment shall be applied, installed, connected, erected, used, cleaned and conditioned in accord with their manufacturer's printed directions unless specified otherwise. Where reference is made to manufacturer's directions, Contractor shall submit specified number of copies of such directions to Architect. Operating and Maintenance instructions for all equipment and materials shall be bound together in complete sets and three copies delivered to Architect prior to final payment.

**END OF SECTION**



**SECTION 012000  
PRICE AND PAYMENT PROCEDURES**

**PART 1 GENERAL**

**1.01 SECTION INCLUDES**

- A. Procedures for preparation and submittal of applications for progress payments.
- B. Change procedures.

**1.02 RELATED REQUIREMENTS**

- A. Section 012100 - Allowances: Payment procedures relating to allowances.
- B. Section 012200 - Unit Prices: Monetary values of unit prices; Payment and modification procedures relating to unit prices.

**1.03 SCHEDULE OF VALUES**

- A. Electronic media printout including equivalent information will be considered in lieu of standard form specified; submit draft to Architect for approval.
- B. Forms filled out by hand will not be accepted.
- C. Submit a printed schedule on AIA Form G703 - Application and Certificate for Payment Continuation Sheet. Contractor's standard form or electronic media printout will be considered.
- D. Submit Schedule of Values electronically as a PDF within 15 days after date of Owner-Contractor Agreement.
- E. Format: Utilize the Table of Contents of this Project Manual. Identify each line item with number and title of the specification Section. Identify site mobilization, bonds and insurance, and accepted alternates, contingency and or other allowances shall be listed on their own separate lines.
- F. Include in each line item, the amount of Allowances specified in this section. For unit cost Allowances, identify quantities taken from Contract Documents multiplied by the unit cost to achieve the total for the item.
- G. Correlate line items in the Schedule of Values with other required administrative forms and schedules, including Submittals Schedule and Application for Payment forms with Continuation Sheets.
- H. Sub-schedules: Where the Work is separated into phases requiring separately phased payments, provide sub-schedules showing values correlated with each phase of payment.
- I. Revise schedule to list approved Change Orders, with each Application For Payment.
- J. Include separately from each line item, a direct proportional amount of Contractor's overhead and profit.
- K. Revise schedule to list approved Change Orders, with each Application For Payment.
- L. Provide breakdown of the Contract Sum in enough detail to facilitate continued evaluation of Applications for Payment and progress reports. Coordinate with the Project Manual table of contents. Provide several line items for principal subcontract amounts, where appropriate. Divide all sections in two lines, one for materials and one for labor for that portion of the work.
- M. Round amounts to nearest whole dollar; total shall equal the Contract Sum.
- N. Provide a separate line item in the Schedule of Values for each part of the Work where Applications for Payment may include materials or equipment purchased or fabricated and stored, but not yet installed.
- O. Provide separate line items in the Schedule of Values for initial cost of materials, for each subsequent stage of completion, and for total installed value of that part of the Work.
- P. Allowances: Provide a separate line item in the Schedule of Values for each allowance. Show line-item value of unit-cost allowances, as a product of the unit cost, multiplied by measured quantity. Use information indicated in the Contract Documents to determine quantities.

- Q. Each item in the Schedule of Values and Applications for Payment shall be complete. Include total cost and proportionate share of general overhead and profit for each item.
  - 1. Temporary facilities and other major cost items that are not direct cost of actual work-in-place may be shown either as separate line items in the Schedule of Values or distributed as general overhead expense, at Contractor's Option.
- R. Schedule Updating: Update and resubmit the Schedule of Values before the next Applications for Payment when Change Orders or Construction Change Directives result in a change in the Contract Sum.

#### **1.04 APPLICATIONS FOR PROGRESS PAYMENTS**

- A. Payment Period: Submit at intervals stipulated in the Agreement.
- B. Electronic media printout including equivalent information will be considered in lieu of standard form specified; submit sample to Architect for approval.
- C. Forms filled out by hand will not be accepted.
- D. Present required information in typewritten form.
- E. Form: AIA G702 Application and Certificate for Payment and AIA G703 - Continuation Sheet including continuation sheets when required.
  - 1. Execute Application on ORIGINAL AIA Documents. Completed (filled out) Documents may be copied for submission. Use of illegal photocopies of AIA Documents will be cause for rejection of Application, and possible delay in payment.
- F. Each Application for Payment shall be consistent with previous applications and payments as certified by Architect and paid for by Owner.
  - 1. Initial Application for Payment, Application for Payment at time of Substantial Completion, and final Application for Payment involve additional requirements.
- G. Payment Application Times: The date for each progress payment is indicated in the Agreement between Owner and Contractor. The period of construction Work covered by each Application for Payment is the period indicated in the Agreement.
- H. Application Preparation: Complete every entry on form. Notarize and execute by a person authorized to sign legal documents on behalf of Contractor. Architect will return incomplete applications without action.
  - 1. Entries shall match data on the Schedule of Values and Contractors Construction Schedule. Use updated schedules if revisions were made.
  - 2. Include amounts of Unit Prices, Change Orders and Construction Change Directives issued before last day of construction period covered by application.
- I. Waivers of Mechanic's Lien: With each Application for Payment, submit waivers of mechanic's lien from every entity who is lawfully entitled to file a mechanic's lien arising out of the Contract and related to the Work covered by the payment.
  - 1. Submit partial waivers on each item for amount requested, before deduction for retainage, on each item.
  - 2. When an application shows completion of an item, submit final or full waivers.
  - 3. Owner reserves the right to designate which entities involved in the Work must submit waivers.
  - 4. Waiver Delays: Submit each Application for Payment with Contractor's Waiver of mechanic's lien for construction period covered by the application.
    - a. Submit final Application for Payment with or preceded by final waivers from every entity involved with performance of the Work covered by the application who is lawfully entitled to a lien.
- J. Initial Application for Payment: Administrative actions and submittals that must precede or coincide with submittal of first Application for Payment include the following:
  - 1. List of subcontractors
  - 2. Schedule of Values
  - 3. Contractor's Construction Schedule (preliminary if not final)
  - 4. Submittals Schedule (preliminary if not final)

5. List of Contractor's staff assignments
  6. Copies of building permits
  7. Copies of authorizations and licenses from authorities having jurisdiction for performance of the work
  8. Certificates of insurance and insurance policies
  9. Performance and payment bonds
  10. Data needed to acquire Owner's insurance
- K. For each item, provide a column for listing each of the following:
1. Item Number.
  2. Description of work.
  3. Scheduled Values.
  4. Previous Applications.
  5. Work in Place and Stored Materials under this Application.
  6. Authorized Change Orders.
  7. Total Completed and Stored to Date of Application.
  8. Percentage of Completion.
  9. Balance to Finish.
  10. Retainage.
- L. Execute certification by signature of authorized officer.
- M. Use data from approved Schedule of Values. Provide dollar value in each column for each line item for portion of work performed and for stored Products.
- N. List each authorized Change Order as a separate line item, listing Change Order number and dollar amount as for an original item of Work.
- O. When Architect requires substantiating information, submit data justifying dollar amounts in question. Provide one copy of data with cover letter for each copy of submittal. Show application number and date, and line item by number and description.
- P. Execute certification by signature of authorized officer.
- Q. Submit one electronic copy of each Application for Payment.

#### **1.05 MODIFICATION PROCEDURES**

- A. For minor changes not involving an adjustment to the Contract Price or Contract Time, Architect will issue instructions directly to Contractor.
- B. Architect will advise of minor changes in the Work not involving an adjustment to Contract Sum or Contract Time as authorized by the Conditions of the Contract by issuing supplemental instructions on AIA Form G710.
- C. For other required changes, Architect will issue a document signed by Owner instructing Contractor to proceed with the change, for subsequent inclusion in a Change Order.
  1. The document will describe the required changes and will designate method of determining any change in Contract Sum or Contract Time.
  2. Promptly execute the change.
- D. For changes for which advance pricing is desired, Architect will issue a document that includes a detailed description of a proposed change with supplementary or revised drawings and specifications, a change in Contract Time for executing the change with a stipulation of any overtime work required and the period of time during which the requested price will be considered valid. Contractor shall prepare and submit a fixed price quotation within seven days.
- E. Contractor may propose a change by submitting a request for change to Architect, describing the proposed change and its full effect on the work, with a statement describing the reason for the change, and the effect on the Contract Sum and Contract Time with full documentation and a statement describing the effect on work by separate or other contractors. Document any requested substitutions in accordance with Section 01 6000.

- F. Computation of Change in Contract Amount: As specified in the Agreement and Conditions of the Contract.
  - 1. For change requested by Architect for work falling under a fixed price contract, the amount will be based on Contractor's price quotation.
  - 2. For change requested by Contractor, the amount will be based on the Contractor's request for a Change Order as approved by Architect.
  - 3. For pre-determined unit prices and quantities, the amount will be based on the fixed unit prices.
- G. Substantiation of Costs: Provide full information required for evaluation.
  - 1. On request, provide the following data:
    - a. Quantities of products, labor, and equipment.
    - b. Taxes, insurance, and bonds.
    - c. Overhead and profit.
    - d. Justification for any change in Contract Time.
    - e. Credit for deletions from Contract, similarly documented.
  - 2. Support each claim for additional costs with additional information:
    - a. Origin and date of claim.
    - b. Dates and times work was performed, and by whom.
    - c. Time records and wage rates paid.
    - d. Invoices and receipts for products, equipment, and subcontracts, similarly documented.
  - 3. For Time and Material work, submit itemized account and supporting data after completion of change, within time limits indicated in the Conditions of the Contract.
- H. Execution of Change Orders: Architect will issue Change Orders for signatures of parties as provided in the Conditions of the Contract.
- I. After execution of Change Order, promptly revise Schedule of Values and Application for Payment forms to record each authorized Change Order as a separate line item and adjust the Contract Sum.
- J. Promptly revise progress schedules to reflect any change in Contract Time, revise sub-schedules to adjust times for other items of work affected by the change, and resubmit.
- K. Promptly enter changes in Project Record Documents.

**1.06 APPLICATION FOR FINAL PAYMENT**

- A. Prepare Application for Final Payment as specified for progress payments, identifying total adjusted Contract Sum, previous payments, and sum remaining due.
- B. Application for Final Payment will not be considered until the following have been accomplished:
  - 1. All closeout procedures specified in Section 017000.
  - 2. Insurance certificates for products and completed operations where required and proof that taxes, fees and similar obligations were paid.
  - 3. Updated final statement, accounting for final changes to the Contract Sum.
  - 4. AIA Document G706, " Contractor's Affidavit of Payment of Debts and Claims."
  - 5. AIA Document G706A, " Contractor's Affidavit of Release of Liens."
  - 6. AIA Document G707, " Consent of Surety to Final Payment."
  - 7. Evidence that claims have been settled.

**PART 2 PRODUCTS - NOT USED**

**PART 3 EXECUTION - NOT USED**

**END OF SECTION**

**SECTION 012300  
ALTERNATES**

**PART 1 GENERAL**

**1.01 SECTION INCLUDES**

- A. Description of Alternates.
- B. Procedures for pricing Alternates.

**1.02 RELATED REQUIREMENTS**

- A. Document 002113 - Instructions to Bidders: Instructions for preparation of pricing for Alternates.
- B. Document 004323 - Alternates Form: List of Alternates as supplement to Bid Form.

**1.03 ACCEPTANCE OF ALTERNATES**

- A. Alternates quoted on Bid Forms will be reviewed and accepted or rejected at Owner's option. Accepted Alternates will be identified in the Owner-Contractor Agreement.
- B. Coordinate related work and modify surrounding work to integrate the Work of each Alternate.

**1.04 SCHEDULE OF ALTERNATES**

- A. Alternate No. 01 - Provide the additive cost to provide Metal Clad Composite Wall Panels in lieu of Fiber Cement Siding:
  - 1. Base Bid Item: Section 07 4646 Fiber Cement Siding and Sheet number A520 including Drawings.
  - 2. Alternate Item: Section 07 4213.23 Metal Composite Material Wall Panels and Sheet number A503 and A520 including Drawings.

**PART 2 PRODUCTS - NOT USED**

**PART 3 EXECUTION - NOT USED**

**END OF SECTION**

**SECTION 013000  
ADMINISTRATIVE REQUIREMENTS**

**PART 1 GENERAL**

**1.01 SECTION INCLUDES**

- A. Electronic document submittal service.
- B. Preconstruction meeting.
- C. Site mobilization meeting.
- D. Progress meetings.
- E. Construction progress schedule.
- F. Submittals for review, information, and project closeout.
- G. Number of copies of submittals.
- H. Submittal procedures.

**1.02 RELATED REQUIREMENTS**

- A. Section 017000 - Execution and Closeout Requirements: Additional coordination requirements.
- B. Section 017800 - Closeout Submittals: Project record documents; operation and maintenance data; warranties and bonds.

**PART 2 PRODUCTS - NOT USED**

**PART 3 EXECUTION**

**3.01 ELECTRONIC DOCUMENT SUBMITTAL**

- A. All documents transmitted for purposes of administration of the contract are to be in electronic (PDF) format that provides electronic stamping and signatures.
  - 1. Besides submittals for review, information, and closeout, this procedure applies to Requests for Interpretation (RFIs), progress documentation, contract modification documents (e.g. supplementary instructions, change proposals, change orders), applications for payment, field reports and meeting minutes, Contractor's correction punchlist, and any other document any participant wishes to make part of the project record.
  - 2. Contractor and Architect are required to use this process.
  - 3. It is Contractor's responsibility to submit documents in allowable PDF format.
  - 4. Users need an email address, Internet access, and PDF review software that includes ability to mark up and apply electronic stamps (such as Adobe Acrobat, [www.adobe.com](http://www.adobe.com), or Bluebeam PDF Revu, [www.bluebeam.com](http://www.bluebeam.com))
  - 5. Paper document transmittals will not be reviewed; emailed electronic documents will not be reviewed.
  - 6. All other specified submittal and document transmission procedures apply, except that electronic document requirements do not apply to samples or color selection charts.
  - 7. PROCORE and similar programs shall be utilized as a means of communication or document transfer between Architect, Owner, and/or Contractor.

**3.02 PRECONSTRUCTION MEETING**

- A. Architect will schedule and administer meeting after Notice of Award.
- B. Attendance Required:
  - 1. Owner.
  - 2. Architect.
  - 3. Contractor.
- C. Agenda:
  - 1. Execution of Owner-Contractor Agreement.
  - 2. Submission of executed bonds and insurance certificates.
  - 3. Distribution of Contract Documents.

4. Submission of list of subcontractors, list of products, schedule of values, and progress schedule.
  5. Designation of personnel representing the parties to Contract and Architect.
  6. Procedures and processing of field decisions, submittals, substitutions, applications for payments, proposal request, Change Orders, and Contract closeout procedures.
  7. Scheduling.
- D. Record minutes and distribute copies within three days after meeting to participants, with one copy to Architect, Owner, participants, and those affected by decisions made.

### **3.03 SITE MOBILIZATION MEETING**

- A. Schedule meeting at the Project site prior to Contractor occupancy.
- B. Attendance Required:
1. Contractor.
  2. Owner.
  3. Architect.
  4. Contractor's superintendent.
  5. Major subcontractors.
- C. Agenda:
1. Use of premises by Owner and Contractor.
  2. Owner's requirements and occupancy prior to completion.
  3. Construction facilities and controls provided by Owner.
  4. Temporary utilities provided by Owner.
  5. Survey and building layout.
  6. Security and housekeeping procedures.
  7. Schedules.
  8. Application for payment procedures.
  9. Procedures for testing.
  10. Procedures for maintaining record documents.
  11. Requirements for start-up of equipment.
  12. Inspection and acceptance of equipment put into service during construction period.
- D. Record minutes and distribute copies within three days after meeting to participants, with one copy to Architect, Owner, participants, and those affected by decisions made.

### **3.04 PROGRESS MEETINGS**

- A. Schedule and administer meetings throughout progress of the work at maximum twice monthly intervals.
- B. Make arrangements for meetings, prepare agenda with copies for participants, preside at meetings.
- C. Attendance Required:
1. Contractor.
  2. Owner.
  3. Architect.
  4. Contractor's superintendent.
  5. Major subcontractors.
- D. Agenda:
1. Review minutes of previous meetings.
  2. Review of work progress.
  3. Field observations, problems, and decisions.
  4. Identification of problems that impede, or will impede, planned progress.
  5. Review of submittals schedule and status of submittals.
  6. Maintenance of progress schedule.
  7. Corrective measures to regain projected schedules.
  8. Planned progress during succeeding work period.

9. Maintenance of quality and work standards.
  10. Effect of proposed changes on progress schedule and coordination.
  11. Other business relating to work.
- E. Record minutes and distribute electronically via email within two days after meeting to participants, with one copy to Architect, Owner, participants, and those affected by decisions made.

### **3.05 CONSTRUCTION PROGRESS SCHEDULE**

- A. Within 10 days after date of the Agreement, submit preliminary schedule defining planned operations for the first 60 days of work, with a general outline for remainder of work.
- B. If preliminary schedule requires revision after review, submit revised schedule within 10 days.
- C. Within 20 days after review of preliminary schedule, submit draft of proposed complete schedule for review.
  1. Include written certification that major contractors have reviewed and accepted proposed schedule.
- D. Within 10 days after joint review, submit complete schedule.
- E. Submit updated schedule with each Application for Payment.

### **3.06 SUBMITTALS FOR REVIEW**

- A. When the following are specified in individual sections, submit them for review:
  1. Product data.
  2. Shop drawings.
  3. Samples for selection.
    - a. Accurate, physical color charts will be submitted. No computer graphics will be allowed.
  4. Samples for verification.
    - a. Contractor shall submit actual samples/color chips for review as requested by Architect when matching existing materials.
- B. Submit to Architect for review for the limited purpose of checking for compliance with information given and the design concept expressed in Contract Documents.
- C. Samples will be reviewed for aesthetic, color, or finish selection.
- D. After review, provide copies and distribute in accordance with SUBMITTAL PROCEDURES article below and for record documents purposes described in Section 017800 - Closeout Submittals.
- E. PROCORE and similar programs shall not be utilized as a means of communication or document transfer between Architect, Owner, and/or Contractor.

### **3.07 SUBMITTALS FOR INFORMATION**

- A. When the following are specified in individual sections, submit them for information:
  1. Design data.
  2. Certificates.
  3. Test reports.
  4. Inspection reports.
  5. Manufacturer's instructions.
  6. Manufacturer's field reports.
  7. Other types indicated.
- B. Submit for Architect's knowledge as contract administrator or for Owner. No action will be taken.

### **3.08 SUBMITTALS FOR PROJECT CLOSEOUT**

- A. Submit Correction Punch List for Substantial Completion.
- B. Submit Final Correction Punch List for Substantial Completion.



- C. When the following are specified in individual sections, submit them at project closeout in compliance with requirements of Section 017800 - Closeout Submittals:
  - 1. Project record documents.
  - 2. Operation and maintenance data.
  - 3. Warranties.
  - 4. Bonds.
  - 5. Other types as indicated.
- D. Submit for Owner's benefit during and after project completion.

### 3.09 NUMBER OF COPIES OF SUBMITTALS

- A. Electronic Documents: Submit one electronic copy in PDF format; an electronically-marked up file will be returned. Create PDFs at native size and right-side up; illegible files will be rejected.
- B. Samples: Submit the number specified in individual specification sections; one of which will be retained by Architect.
  - 1. After review, produce duplicates.
  - 2. Retained samples will not be returned to Contractor unless specifically so stated.

### 3.10 SUBMITTAL PROCEDURES

- A. General Requirements:
- B. Shop Drawing Procedures:
  - 1. Prepare accurate, drawn-to-scale, original shop drawing documentation by interpreting Contract Documents and coordinating related work.
  - 2. Generic, non-project-specific information submitted as shop drawings do not meet the requirements for shop drawings.
- C. Transmit each submittal with approved form.
- D. Contractor shall be responsible for submitting all documents in electronic (PDF) format and transmitted via email.
  - 1. Provide electronic stamping and signatures.
  - 2. Beside submittal for review, information and closeout, this procedure applies to requests for information (RFI's), progress documentation, field reports and meeting minutes.
  - 3. Files shall be limited to 10 MB.
  - 4. File naming convention
    - a. The extension should be .pdf for Acrobat files.
    - b. The file name should be in the form of Division Number and Document Title.
      - 1) Example: 08 1113 Hollow Metal Doors and Frames
  - 5. No security features shall be enabled.
  - 6. Submittals containing information for more than one specification section shall have all sections identified on the transmittal according to the above numbering and name format.
- E. Sequentially number the transmittal form. Revise submittals with original number and a sequential alphabetic suffix.
- F. Identify Project, Contractor, Subcontractor or supplier; pertinent drawing and detail number, and specification section number, as appropriate on each copy.
- G. Apply Contractor's stamp, **signed or initialed** certifying that review, approval, verification of Products required, field dimensions, adjacent construction Work, and coordination of information is in accordance with the requirements of the Work and Contract Documents.
  - 1. Submittals not reviewed by general contractor will be rejected and returned without review.
- H. Deliver submittals to Architect at the following email address.
  - 1. bhall@martin-riley.com
- I. Schedule submittals to expedite the Project, and coordinate submission of related items.
- J. For each submittal for review, allow 45 days excluding delivery time to and from the Contractor.

1. The review period will not be shortened for failure of the Contractor to anticipate construction schedule conflicts.
- K. Identify variations from Contract Documents and Product or system limitations that may be detrimental to successful performance of the completed Work.
- L. Provide space for Contractor and Architect review stamps.
- M. When revised for resubmission, identify all changes made since previous submission.
- N. Distribute reviewed submittals as appropriate. Instruct parties to promptly report any inability to comply with requirements.
- O. Submittals not requested will not be recognized or processed.
- P. Shop Drawings, Product Data, Samples and similar submittals are not Contract Documents. Their purpose is to demonstrate the way by which the Contractor proposes to conform to the information given and the design concept expressed in the Contract Documents for those portions of the Work for which the Contract Documents require submittals. Informational submittals upon which the Architect is not expected to take responsive action may be so identified in the Contract Documents. Submittals that are not required by the Contract Documents may be returned by the Architect without action.
- Q. The Contractor shall review for compliance with the Contract Documents, approve and submit to the Architect Shop Drawings, Product Data, Samples and similar submittals required by the Contract Documents in accordance with the submittal schedule approved by the Architect or, in the absence of an approved submittal schedule, with reasonable promptness and in such sequence as to cause no delay in the Work or in the activities of the Owner or of separate contractors.
- R. By submitting Shop Drawings, Product Data, Samples and similar submittals, the Contractor represents to the Owner and Architect that the Contractor has:
  1. Reviewed and approved them.
  2. Determined and verified materials, field measurements and field construction criteria related thereto, or will do so.
  3. Checked and coordinated the information contained within such submittals with the requirements of the Work and of the Contract Documents.
- S. The Contractor shall perform no portion of the Work for which the Contract Documents require submittal and review of Shop Drawings, Product Data, Samples or similar submittals until the respective submittal has been approved by the Architect.
- T. The Work shall be in accordance with approved submittals except that the Contractor shall not be relieved of responsibility for deviations from requirements of the Contract Documents by the Architect's approval of Shop Drawings, Product Data, Samples or similar submittals unless the Contractor has specifically informed the Architect in writing of such deviation at the time of submittal and:
  1. The Architect has given written approval to the specific deviation as a minor change in the Work.
  2. A Change Order or Construction Change Directive has been issued authorizing the deviation. The Contractor shall not be relieved of responsibility for errors or omissions in Shop Drawings, Product Data, Samples or similar submittals by the Architect's approval thereof.
- U. The Contractor shall direct specific attention, in writing or on resubmitted Shop Drawings, Product Data, Samples or similar submittals, to revisions other than those requested by the Architect on previous submittals. In the absence of such written notice, the Architect's approval of a resubmission shall not apply to such revisions.

**END OF SECTION**

**SECTION 014000  
QUALITY REQUIREMENTS**

**PART 1 GENERAL**

**1.01 SECTION INCLUDES**

- A. Submittals.
- B. Quality assurance.
- C. Testing and inspection agencies and services.
- D. Control of installation.
- E. Manufacturers' field services.
- F. Defect Assessment.

**1.02 RELATED REQUIREMENTS**

- A. Section 013000 - Administrative Requirements: Submittal procedures.
- B. Section 014219 - Reference Standards.
- C. Section 016000 - Product Requirements: Requirements for material and product quality.

**1.03 REFERENCE STANDARDS**

- A. ASTM C1021 - Standard Practice for Laboratories Engaged in Testing of Building Sealants; 2008 (Reapproved 2019).
- B. ASTM C1077 - Standard Practice for Agencies Testing Concrete and Concrete Aggregates for Use in Construction and Criteria for Testing Agency Evaluation; 2017.
- C. ASTM C1093 - Standard Practice for Accreditation of Testing Agencies for Masonry; 2022.
- D. ASTM D3740 - Standard Practice for Minimum Requirements for Agencies Engaged in Testing and/or Inspection of Soil and Rock as Used in Engineering Design and Construction; 2019.
- E. ASTM E329 - Standard Specification for Agencies Engaged in Construction Inspection, Testing, or Special Inspection; 2021.
- F. ASTM E543 - Standard Specification for Agencies Performing Nondestructive Testing; 2021.
- G. IAS AC89 - Accreditation Criteria for Testing Laboratories; 2021.

**1.04 SUBMITTALS**

- A. See Section 013000 - Administrative Requirements, for submittal procedures.
- B. Test Reports: After each test/inspection, promptly submit two copies of report to Architect and to Contractor.
  - 1. Include:
    - a. Date issued.
    - b. Project title and number.
    - c. Name of inspector.
    - d. Date and time of sampling or inspection.
    - e. Identification of product and specifications section.
    - f. Location in the Project.
    - g. Type of test/inspection.
    - h. Date of test/inspection.
    - i. Results of test/inspection.
    - j. Compliance with Contract Documents.
    - k. When requested by Architect, provide interpretation of results.
  - 2. Test report submittals are for Architect's knowledge as contract administrator for the limited purpose of assessing compliance with information given and the design concept expressed in the Contract Documents, or for Owner's information.
- C. Certificates: When specified in individual specification sections, submit certification by the manufacturer and Contractor or installation/application subcontractor to Architect, in quantities

specified for Product Data.

1. Indicate material or product complies with or exceeds specified requirements. Submit supporting reference data, affidavits, and certifications as appropriate.
- D. Manufacturer's Instructions: When specified in individual specification sections, submit printed instructions for delivery, storage, assembly, installation, start-up, adjusting, and finishing, for the Owner's information. Indicate special procedures, perimeter conditions requiring special attention, and special environmental criteria required for application or installation.
- E. Erection Drawings: Submit drawings for Architect's benefit as contract administrator or for Owner.
1. Submit for information for the limited purpose of assessing compliance with information given and the design concept expressed in the Contract Documents.

#### **1.05 QUALITY ASSURANCE**

- A. Testing Agency Qualifications:
1. Prior to start of work, submit agency name, address, and telephone number, and names of full time registered Engineer and responsible officer.

#### **1.06 TESTING AND INSPECTION AGENCIES AND SERVICES**

- A. Contractor shall employ and pay for services of an independent testing agency to perform specified testing.
- B. Employment of agency in no way relieves Contractor of obligation to perform Work in accordance with requirements of Contract Documents.
- C. Contractor Employed Agency:
1. Testing agency: Comply with requirements of ASTM E329, ASTM E543, ASTM C1021, ASTM C1077, ASTM C1093, and ASTM D3740.
  2. Testing Equipment: Calibrated at reasonable intervals either by NIST or using an NIST established Measurement Assurance Program, under a laboratory measurement quality assurance program.

### **PART 2 PRODUCTS - NOT USED**

### **PART 3 EXECUTION**

#### **3.01 CONTROL OF INSTALLATION**

- A. Monitor quality control over suppliers, manufacturers, products, services, site conditions, and workmanship, to produce work of specified quality.
- B. Comply with manufacturers' instructions, including each step in sequence.
- C. Should manufacturers' instructions conflict with Contract Documents, request clarification from Architect before proceeding.
- D. Comply with specified standards as minimum quality for the work except where more stringent tolerances, codes, or specified requirements indicate higher standards or more precise workmanship.
- E. Have work performed by persons qualified to produce required and specified quality.
- F. Verify that field measurements are as indicated on shop drawings or as instructed by the manufacturer.
- G. Secure products in place with positive anchorage devices designed and sized to withstand stresses, vibration, physical distortion, and disfigurement.

#### **3.02 TESTING AND INSPECTION**

- A. Testing Agency Duties:
1. Provide qualified personnel at site. Cooperate with Architect and Contractor in performance of services.
  2. Perform specified sampling and testing of products in accordance with specified standards.
  3. Ascertain compliance of materials and mixes with requirements of Contract Documents.

4. Promptly notify Architect and Contractor of observed irregularities or non-compliance of Work or products.
  5. Perform additional tests and inspections required by Architect.
  6. Submit reports of all tests/inspections specified.
- B. Limits on Testing/Inspection Agency Authority:
1. Agency may not release, revoke, alter, or enlarge on requirements of Contract Documents.
  2. Agency may not approve or accept any portion of the Work.
  3. Agency may not assume any duties of Contractor.
  4. Agency has no authority to stop the Work.
- C. Contractor Responsibilities:
1. Deliver to agency at designated location, adequate samples of materials proposed to be used that require testing, along with proposed mix designs.
  2. Cooperate with laboratory personnel, and provide access to the Work and to manufacturers' facilities.
  3. Provide incidental labor and facilities:
    - a. To provide access to Work to be tested/inspected.
    - b. To obtain and handle samples at the site or at source of Products to be tested/inspected.
    - c. To facilitate tests/inspections.
    - d. To provide storage and curing of test samples.
  4. Notify Architect and laboratory 24 hours prior to expected time for operations requiring testing/inspection services.
  5. Employ services of an independent qualified testing laboratory and pay for additional samples, tests, and inspections required by Contractor beyond specified requirements.
  6. Arrange with Owner's agency and pay for additional samples, tests, and inspections required by Contractor beyond specified requirements.
- D. Re-testing required because of non-compliance with specified requirements shall be performed by the same agency on instructions by Architect.
- E. Additional tests and re-testing required because of non-compliance with specified requirements shall be paid for by Contractor.
- F. Test two additional for each test that does not comply.

### **3.03 MANUFACTURERS' FIELD SERVICES**

- A. When specified in individual specification sections, require material or product suppliers or manufacturers to provide qualified staff personnel to observe site conditions, conditions of surfaces and installation, quality of workmanship, start-up of equipment, test, adjust, and balance equipment as applicable, and to initiate instructions when necessary.
- B. Report observations and site decisions or instructions given to applicators or installers that are supplemental or contrary to manufacturers' written instructions.

### **3.04 DEFECT ASSESSMENT**

- A. Replace Work or portions of the Work not complying with specified requirements.
- B. If, in the opinion of Architect, it is not practical to remove and replace the work, Architect will direct an appropriate remedy or adjust payment.

**END OF SECTION**

**SECTION 015000  
TEMPORARY FACILITIES AND CONTROLS**

**PART 1 GENERAL**

**1.01 SECTION INCLUDES**

- A. Temporary utilities.
- B. Temporary sanitary facilities.
- C. Temporary Controls: Barriers, enclosures, and fencing.
- D. Security requirements.
- E. Vehicular access and parking.
- F. Waste removal facilities and services.
- G. Temporary Fire Protection.

**1.02 TEMPORARY UTILITIES**

- A. Existing facilities may not be used without the expressed written consent of the owner with regard to the specific area or building and the purpose for which the contractor wishes to use the building or area.
- B. New permanent facilities may not be used.
- C. Use trigger-operated nozzles for water hoses, to avoid waste of water.

**1.03 TEMPORARY SANITARY FACILITIES**

- A. Provide and maintain required facilities and enclosures. Provide at time of project mobilization.
- B. Provide temporary toilets, wash facilities, and drinking water for use of construction personnel. Comply with authorities having jurisdiction for type, number, location, operation, and maintenance of fixtures and facilities. Provide toilet tissue, paper towels and similar disposable materials for each facility.
- C. Toilets: Provide self-contained, single occupant chemical, or aerated recirculation type toilet units. Toilet units must be properly vented, fully enclosed with glass-fiber-reinforced polyester shell or similar non-absorbent material. Shield toilets to ensure privacy. Use of pit-type toilets will not be permitted.
- D. Wash Facilities: Install wash facilities supplied with potable water at convenient locations for personnel involved in handling materials that require wash-up. Dispose of drainage properly. Supply cleaning compounds.
- E. Drinking-Water Facilities: Provide containerized, tap-dispenser, bottled drinking-water units.
- F. Maintain daily in clean and sanitary condition.

**1.04 BARRIERS**

- A. Provide barriers to prevent unauthorized entry to construction areas, to prevent access to areas that could be hazardous to workers or the public, to allow for owner's use of site and to protect existing facilities and adjacent properties from damage from construction operations and demolition.
- B. Provide protection for plants and lawns designated to remain. Replace damaged plants.
- C. Protect non-owned vehicular traffic, stored materials, site, and structures from damage.
- D. Warning Signs and Lights: Comply with standards and code requirements for erection of barricades. Paint appropriate warning signs to inform personnel and the public of the hazard being protected against. Where needed provide lighting, including flashing lights.

**1.05 FENCING**

- A. Construction: Commercial grade chain link fence.
- B. Provide 6 foot (1.8 m) high fence around construction staging area; equip with vehicular and pedestrian gates with locks.

## **1.06 SECURITY**

- A. Provide security and facilities to protect Work, existing facilities, and Owner's operations from unauthorized entry, vandalism, or theft.

## **1.07 VEHICULAR ACCESS AND PARKING**

- A. Coordinate access and haul routes with governing authorities and Owner.
- B. Provide and maintain access to fire hydrants, free of obstructions.
- C. Provide means of removing mud from vehicle wheels before entering streets.
- D. Provide temporary parking areas to accommodate construction personnel. When site space is not adequate, provide additional off-site parking.

## **1.08 WASTE REMOVAL**

- A. Provide waste removal facilities and services as required to maintain the site in clean and orderly condition.
- B. Provide containers with lids. Remove trash from site periodically.
- C. If materials to be recycled or re-used on the project must be stored on-site, provide suitable non-combustible containers; locate containers holding flammable material outside the structure unless otherwise approved by the authorities having jurisdiction.

## **1.09 TEMPORARY FIRE PROTECTION**

- A. Temporary Fire Protection: Until roofing operations are completed, supply temporary fire-protection. Install and maintain fire extinguishers of types needed to protect against controllable fire losses. Comply with NFPA 10 and 241.
  - 1. Locate fire extinguishers where convenient and effective for their intended purpose, but not less than one extinguisher on roof, at or near each access area. Maintain unobstructed access to fire extinguisher.
  - 2. Store combustible materials in containers in fire-safe locations.
  - 3. Prohibit smoking in hazardous fire-exposure areas.
  - 4. Provide supervision of welding operations, combustion-type temporary heating units, and similar sources of fire ignition.

## **1.10 REMOVAL OF UTILITIES, FACILITIES, AND CONTROLS**

- A. Remove temporary utilities, equipment, facilities, materials, prior to Date of Substantial Completion inspection.
- B. Remove underground installations to a minimum depth of 2 feet (600 mm). Grade site as indicated.
- C. Clean and repair damage caused by installation or use of temporary work.
- D. Restore existing facilities used during construction to original condition.
- E. Remove all temporary project signage erected during construction and clean and repair damage from same filling holes and repairing landscaping to match surrounding area.

## **PART 2 PRODUCTS**

### **2.01 MATERIALS**

- A. Tarpaulins: Waterproof, Fire-resistant, UL-labeled tarpaulins with flame-spread rating of 15 or less, are to be used for temporary protection of roofing materials on site. Manufacturers plastic shrink wrap will not be acceptable. For interior protection provide translucent, nylon-reinforced, laminated polyethylene or polyvinyl chloride, fire-retardant tarpaulins.
- B. Equipment: Provide equipment suitable for its use intended. Equipment is to be undamaged and in serviceable condition.
  - 1. Water hoses: Standard 3/4-inch (19 mm), heavy-duty, abrasion-resistant, flexible rubber hoses 100 feet (30m) long. Provide adjustable shutoff nozzles at hose discharge.
  - 2. Electrical Outlets: Properly configured, NEMA-polarized outlets. Provide outlets equipped with ground-fault circuit interrupters, reset button, and pilot light for connection of power

tools and equipment.

3. Electrical Power Cords: Grounded extension cords. Use hard-service cords where exposed to abrasion and traffic.
4. Fire Extinguishers: Hand carried, portable, UL-rated. Class A fire extinguishers for temporary offices and similar spaces. In other locations, provide hand-carried, portable, UL-rated, Class ABC, dry-chemical extinguishers or combination of extinguishers of NFPA-recommended classes for the exposures.
  - a. Comply with NFPA 10 and NFPA 241 for classification, extinguishing agent, and size required by location and class of fire exposure.

### **PART 3 EXECUTION**

#### **3.01 CONDITIONS OF USE**

- A. Locate facilities where they will service the project adequately and result in minimum interference with performance of the Work. Relocate and modify facilities as required.
- B. Keep temporary facilities clean and neat in appearance. Operate safely and efficiently. Relocate as the Work progressed. Do not overload facilities or permit them to interfere with progress. Take necessary fire-prevention measures. Do not allow hazardous, dangerous, or unsanitary conditions, or public nuisances to develop or persist on-site.

**END OF SECTION**



**SECTION 015713  
TEMPORARY EROSION AND SEDIMENT CONTROL**

**PART 1 GENERAL**

**1.01 SECTION INCLUDES**

- A. Prevention of erosion due to construction activities.
- B. Prevention of sedimentation of waterways, open drainage ways, and storm and sanitary sewers due to construction activities.
- C. Restoration of areas eroded due to insufficient preventive measures.
- D. Compensation of Owner for fines levied by authorities having jurisdiction due to non-compliance by Contractor.

**1.02 RELATED REQUIREMENTS**

- A. Section 312200 - Grading: Temporary and permanent grade changes for erosion control.

**1.03 REFERENCE STANDARDS**

**1.04 SUBMITTALS**

- A. See Section 013000 - Administrative Requirements, for submittal procedures.
- B. Certificate: Mill certificate for silt fence fabric attesting that fabric and factory seams comply with specified requirements, signed by legally authorized official of manufacturer; indicate actual minimum average roll values; identify fabric by roll identification numbers.

**PART 2 PRODUCTS**

**2.01 MATERIALS**

- A. Mulch: Use one of the following:
  - 1. Erosion control matting or netting.
- B. Grass Seed For Temporary Cover: Select a species appropriate to climate, planting season, and intended purpose. If same area will later be planted with permanent vegetation, do not use species known to be excessively competitive or prone to volunteer in subsequent seasons.
- C. Bale Stakes: One of the following, minimum 3 feet (1 m) long:
  - 1. Steel U- or T-section, with minimum mass of 1.33 pound per linear foot (1.98 kg per linear m).
  - 2. Wood, 2 by 2 inches (50 by 50 mm) in cross section.
- D. Silt Fence Fabric: Polypropylene geotextile resistant to common soil chemicals, mildew, and insects; non-biodegradable; in longest lengths possible; fabric including seams with the following minimum average roll lengths:
  - 1. Average Opening Size: 30 U.S. Std. Sieve (0.600 mm), maximum, when tested in accordance with ASTM D4751.
  - 2. Permittivity:  $0.05 \text{ sec}^{-1}$ , minimum, when tested in accordance with ASTM D4491/D4491M.
  - 3. Ultraviolet Resistance: Retaining at least 70 percent of tensile strength, when tested in accordance with ASTM D4355/D4355M after 500 hours exposure.
  - 4. Tensile Strength: 100 pounds-force (450 N), minimum, in cross-machine direction; 124 pounds-force (550 N), minimum, in machine direction; when tested in accordance with ASTM D4632/D4632M.
  - 5. Elongation: 15 to 30 percent, when tested in accordance with ASTM D4632/D4632M.
  - 6. Tear Strength: 55 pounds-force (245 N), minimum, when tested in accordance with ASTM D4533/D4533M.
  - 7. Color: Manufacturer's standard, with embedment and fastener lines preprinted.
  - 8. Manufacturers:
    - a. TenCate: [www.tencate.com/#sle](http://www.tencate.com/#sle).
    - b. North American Green: [www.nagreen.com/#sle](http://www.nagreen.com/#sle).
    - c. Propex Geosynthetics: [www.geotextile.com/#sle](http://www.geotextile.com/#sle).

- d. Substitutions: See Section 016000 - Product Requirements.
- E. Silt Fence Posts: One of the following, minimum 5 feet (1500 mm) long:

**END OF SECTION**

**SECTION 016000  
PRODUCT REQUIREMENTS**

**PART 1 GENERAL**

**1.01 SECTION INCLUDES**

- A. General product requirements.
- B. Transportation, handling, storage and protection.
- C. Product option requirements.
- D. Substitution limitations.
- E. Maintenance materials, including extra materials, spare parts, tools, and software.

**1.02 RELATED REQUIREMENTS**

- A. Section 016116 - Volatile Organic Compound (VOC) Content Restrictions: Requirements for VOC-restricted product categories.

**1.03 SUBMITTALS**

- A. Product Data Submittals: Submit manufacturer's standard published data. Mark each copy to identify applicable products, models, options, and other data. Supplement manufacturers' standard data to provide information specific to this Project.
- B. Shop Drawing Submittals: Prepared specifically for this Project; indicate utility and electrical characteristics, utility connection requirements, and location of utility outlets for service for functional equipment and appliances.
- C. Sample Submittals: Illustrate functional and aesthetic characteristics of the product, with integral parts and attachment devices. Coordinate sample submittals for interfacing work.
  - 1. For selection from standard finishes, submit samples of the full range of the manufacturer's standard colors, textures, and patterns.
- D. Indicate utility and electrical characteristics, utility connection requirements, and location of utility outlets for service for functional equipment and appliances.

**PART 2 PRODUCTS**

**2.01 NEW PRODUCTS**

- A. Provide new products unless specifically required or permitted by Contract Documents.
- B. DO NOT USE products having any of the following characteristics:
  - 1. Made using or containing CFC's or HCFC's.
  - 2. Made of wood from newly cut old growth timber.
  - 3. Containing lead, cadmium, asbestos, or PCB's.
- C. Where all other criteria are met, Contractor shall give preference to products that:
  - 1. If used on interior, have lower emissions, as defined in Section 016116.
  - 2. If wet-applied, have lower VOC content, as defined in Section 016116.
  - 3. Are extracted, harvested, and/or manufactured closer to the location of the project.
  - 4. Are made of recycled materials.
  - 5. Have a published GreenScreen Chemical Hazard Analysis.

**2.02 PRODUCT OPTIONS**

- A. Products Specified by Reference Standards or by Description Only: Use any product meeting those standards or description.
- B. Products Specified by Naming One or More Manufacturers: Use a product of one of the manufacturers named and meeting specifications, no options or substitutions allowed.
- C. Products Specified by Naming One or More Manufacturers with a Provision for Substitutions: Submit a request for substitution for any manufacturer not named.
- D. Products specified as "Basis of Design": The product has been selected as an example and standard of the performance, appearance, or function desired, or for one or more other

reasons. The product named is used as the basis of comparison of other products which may be proposed or submitted for review. In some cases, other details or construction assemblies are based on the characteristics of the product named. Products named in addition to the Basis of Design product must still comply with other technical criteria and requirements listed.

### **2.03 MAINTENANCE MATERIALS**

- A. Furnish extra materials, spare parts, tools, and software of types and in quantities specified in individual specification sections.
- B. Deliver to Project site; obtain receipt prior to final payment.

## **PART 3 EXECUTION**

### **3.01 SUBSTITUTION PROCEDURES**

- A. Document each request with complete data substantiating compliance of proposed substitution with Contract Documents.
- B. A request for substitution constitutes a representation that the submitter:
  - 1. Has investigated proposed product and determined that it meets or exceeds the quality level of the specified product.
  - 2. Agrees to provide the same warranty for the substitution as for the specified product.
  - 3. Agrees to coordinate installation and make changes to other Work that may be required for the Work to be complete with no additional cost to Owner.
  - 4. Waives claims for additional costs or time extension that may subsequently become apparent.

### **3.02 TRANSPORTATION AND HANDLING**

- A. Package products for shipment in manner to prevent damage; for equipment, package to avoid loss of factory calibration.
- B. If special precautions are required, attach instructions prominently and legibly on outside of packaging.
- C. Coordinate schedule of product delivery to designated prepared areas in order to minimize site storage time and potential damage to stored materials.
- D. Transport and handle products in accordance with manufacturer's instructions.
- E. Transport materials in covered trucks to prevent contamination of product and littering of surrounding areas.
- F. Promptly inspect shipments to ensure that products comply with requirements, quantities are correct, and products are undamaged.
- G. Provide equipment and personnel to handle products by methods to prevent soiling, disfigurement, or damage, and to minimize handling.
- H. Arrange for the return of packing materials, such as wood pallets, where economically feasible.

### **3.03 STORAGE AND PROTECTION**

- A. Designate receiving/storage areas for incoming products so that they are delivered according to installation schedule and placed convenient to work area in order to minimize waste due to excessive materials handling and misapplication.
- B. Store and protect products in accordance with manufacturers' instructions.
- C. Store with seals and labels intact and legible.
- D. Store sensitive products in weathertight, climate-controlled enclosures in an environment favorable to product.
- E. For exterior storage of fabricated products, place on sloped supports above ground.
- F. Protect products from damage or deterioration due to construction operations, weather, precipitation, humidity, temperature, sunlight and ultraviolet light, dirt, dust, and other contaminants.
- G. Comply with manufacturer's warranty conditions, if any.

- H. Cover products subject to deterioration with impervious sheet covering. Provide ventilation to prevent condensation and degradation of products.
- I. Prevent contact with material that may cause corrosion, discoloration, or staining.
- J. Provide equipment and personnel to store products by methods to prevent soiling, disfigurement, or damage.
- K. Arrange storage of products to permit access for inspection. Periodically inspect to verify products are undamaged and are maintained in acceptable condition.

**END OF SECTION**

**SECTION 016116  
VOLATILE ORGANIC COMPOUND (VOC) CONTENT RESTRICTIONS**

**PART 1 GENERAL**

**1.01 SECTION INCLUDES**

- A. Requirements for Indoor-Emissions-Restricted products.
- B. Requirements for VOC-Content-Restricted products.
- C. VOC restrictions for product categories listed below under "DEFINITIONS."
- D. All products of each category that are installed in the project must comply; Owner's project goals do not allow for partial compliance.

**1.02 RELATED REQUIREMENTS**

- A. Section 013000 - Administrative Requirements: Submittal procedures.
- B. Section 016000 - Product Requirements: Fundamental product requirements, substitutions and product options, delivery, storage, and handling.
- C. Section 079200 - Joint Sealants: Emissions-compliant sealants.

**1.03 DEFINITIONS**

- A. Indoor-Emissions-Restricted Products: All products in the following product categories, whether specified or not:
- B. VOC-Content-Restricted Products: All products in the following product categories, whether specified or not:
  - 1. Exterior and interior paints and coatings applied on site.
  - 2. Exterior and interior adhesives and sealants applied on site, including flooring adhesives.
  - 3. Wet-applied waterproofing.
- C. VOC-Restricted Products: All products of each of the following categories when installed or applied on-site in the building interior:
  - 1. Adhesives, sealants, and sealer coatings.
  - 2. Carpet.
  - 3. Carpet tile.
  - 4. Resilient floor coverings.
  - 5. Wood flooring.
  - 6. Paints and coatings.
  - 7. Insulation.
  - 8. Gypsum board.
  - 9. Acoustical ceilings and panels.
  - 10. Cabinet work.
- D. Interior of Building: Anywhere inside the exterior weather barrier.
- E. Adhesives: All gunnable, trowelable, liquid-applied, and aerosol adhesives, whether specified or not; including flooring adhesives, resilient base adhesives, and pipe jointing adhesives.
- F. Sealants: All gunnable, trowelable, and liquid-applied joint sealants and sealant primers, whether specified or not; including firestopping sealants and duct joint sealers.
- G. Inherently Non-Emitting Materials: Products composed wholly of minerals or metals, unless they include organic-based surface coatings, binders, or sealants; and specifically the following:
  - 1. Concrete.
  - 2. Clay brick.
  - 3. Metals that are plated, anodized, or powder-coated.
  - 4. Glass.
  - 5. Ceramics.
  - 6. Solid wood flooring that is unfinished and untreated.

#### 1.04 REFERENCE STANDARDS

- A. 40 CFR 59, Subpart D - National Volatile Organic Compound Emission Standards for Architectural Coatings; U.S. Environmental Protection Agency; current edition.
- B. ASTM D3960 - Standard Practice for Determining Volatile Organic Compound (VOC) Content of Paints and Related Coatings; 2005 (Reapproved 2018).
- C. CARB (SCM) - Suggested Control Measure for Architectural Coatings; California Air Resources Board; 2020.
- D. CRI (GLP) - Green Label Plus Testing Program - Certified Products; Current Edition.
- E. GreenSeal GS-36 - Standard for Adhesives for Commercial Use; 2013.
- F. SCAQMD 1113 - Architectural Coatings; 1977, with Amendment (2016).
- G. SCAQMD 1168 - Adhesive and Sealant Applications; 1989, with Amendment (2022).

#### 1.05 SUBMITTALS

- A. See Section 013000 - Administrative Requirements, for submittal procedures.
- B. Evidence of Compliance: Submit for each different product in each applicable category.
- C. Product Data: For each VOC-restricted product used in the project, submit evidence of compliance.

### PART 2 PRODUCTS

#### 2.01 MATERIALS

- A. All Products: Comply with the most stringent of federal, State, and local requirements, or these specifications.
- B. VOC-Content-Restricted Products: VOC content not greater than required by the following:
  - 1. Adhesives, Including Flooring Adhesives: SCAQMD 1168 Rule.
  - 2. Joint Sealants: SCAQMD 1168 Rule.
  - 3. Paints and Coatings: Each color; most stringent of the following:
    - a. 40 CFR 59, Subpart D.
    - b. SCAQMD 1113 Rule.
    - c. CARB (SCM).
  - 4. Wet-Applied Roofing and Waterproofing: Comply with requirements for paints and coatings.
- C. Adhesives and Joint Sealants: Provide only products having volatile organic compound (VOC) content not greater than required by South Coast Air Quality Management District Rule No.1168.
  - 1. Evidence of Compliance: Acceptable types of evidence are:
    - a. Report of laboratory testing performed in accordance with requirements.
- D. Aerosol Adhesives: Provide only products having volatile organic compound (VOC) content not greater than required by GreenSeal GS-36.
  - 1. Evidence of Compliance: Acceptable types of evidence are:
    - a. Current GreenSeal Certification.
- E. Paints and Coatings:
  - 1. Provide coatings that comply with the most stringent requirements specified in the following:
    - a. 40 CFR 59, Subpart D--National Volatile Organic Compound Emission Standards for Architectural Coatings.
    - b. Architectural coatings VOC limits of state in which the project is located.
  - 2. Determination of VOC Content: Testing and calculation in accordance with 40 CFR 59, Subpart D (EPA Method 24), exclusive of colorants added to a tint base and water added at project site; or other method acceptable to authorities having jurisdiction.
  - 3. Evidence of Compliance: Acceptable types of evidence are:
    - a. Report of laboratory testing performed in accordance with requirements.

- F. Carpet Tile and Adhesive: Provide products having VOC content not greater than that required for CRI Green Label Plus certification.
  - 1. Evidence of Compliance: Acceptable types of evidence are:
    - a. Current Green Label Plus Certification.
    - b. Report of laboratory testing performed in accordance with requirements.
- G. Carpet Tile and Adhesive: Provide products having VOC content as specified in Section 09 6813.

**PART 3 EXECUTION**

**3.01 FIELD QUALITY CONTROL**

- A. Owner reserves the right to reject non-compliant products, whether installed or not, and require their removal and replacement with compliant products at no extra cost to Owner.
- B. Additional costs to restore indoor air quality due to installation of non-compliant products will be borne by Contractor.

**END OF SECTION**



**SECTION 017000  
EXECUTION AND CLOSEOUT REQUIREMENTS**

**PART 1 GENERAL**

**1.01 SECTION INCLUDES**

- A. Examination, preparation, and general installation procedures.
- B. Requirements for alterations work, including selective demolition, except removal, disposal, and/or remediation of hazardous materials and toxic substances.
- C. Pre-installation meetings.
- D. Cutting and patching.
- E. Surveying for laying out the work.
- F. Cleaning and protection.
- G. Starting of systems and equipment.
- H. Demonstration and instruction of Owner personnel.
- I. Closeout procedures, including Contractor's Correction Punch List, except payment procedures.
- J. General requirements for maintenance service.

**1.02 RELATED REQUIREMENTS**

- A. Section 013000 - Administrative Requirements: Submittals procedures, Electronic document submittal service.
- B. Section 014000 - Quality Requirements: Testing and inspection procedures.
- C. Section 017800 - Closeout Submittals: Project record documents, operation and maintenance data, warranties, and bonds.
- D. Section 078400 - Firestopping.

**1.03 SUBMITTALS**

- A. See Section 013000 - Administrative Requirements, for submittal procedures.
- B. Cutting and Patching: Submit written request in advance of cutting or alteration that affects:
  - 1. Structural integrity of any element of Project.
    - a. Do not cut and patch structural elements in a manner that could change their load supporting capacity or load deflection ratio.
  - 2. Integrity of weather exposed or moisture resistant element.
  - 3. Efficiency, maintenance, or safety of any operational element.
    - a. Do not cut and patch operating elements and related components in a manner that results in reducing their capacity to perform as intended or that results in increased maintenance or decreased operational life or safety.
  - 4. Visual qualities of sight exposed elements.
    - a. Visual Requirements: Do not cut and patch construction in a manner that results in visual evidence of cutting and patching. Do not cut and patch construction exposed on the exterior or in occupied spaces in a manner that would, in the Architect's opinion, reduce the building's aesthetic qualities. Remove and replace construction that has been cut and patched in a visually unsatisfactory manner.
  - 5. Work of Owner or separate Contractor.
  - 6. Include in request:
    - a. Identification of Project.
    - b. Location and description of affected work.
    - c. Necessity for cutting or alteration.
    - d. Description of proposed work and products to be used.
    - e. Effect on work of Owner or separate Contractor.
    - f. Written permission of affected separate Contractor.

- g. Date and time work will be executed.
- C. Obtain approval of cutting and patching proposal before cutting and patching. Approval does not waive right to later require removal and replacement of unsatisfactory work.
- D. Project Record Documents: Accurately record actual locations of capped and active utilities.

#### **1.04 QUALIFICATIONS**

- A. For surveying work, employ a land surveyor registered in Wisconsin and acceptable to Architect. Submit evidence of surveyor's Errors and Omissions insurance coverage in the form of an Insurance Certificate. Employ only individual(s) trained and experienced in collecting and recording accurate data relevant to ongoing construction activities,
- B. For field engineering, employ a professional engineer of the discipline required for specific service on Project, licensed in Wisconsin. Employ only individual(s) trained and experienced in establishing and maintaining horizontal and vertical control points necessary for laying out construction work on project of similar size, scope and/or complexity.
- C. For design of temporary shoring and bracing, employ a Professional Engineer experienced in design of this type of work and licensed in the State of Wisconsin.

#### **1.05 PROJECT CONDITIONS**

- A. Grade site to drain. Maintain excavations free of water. Provide, operate, and maintain pumping equipment.
- B. Protect site from puddling or running water. Provide water barriers as required to protect site from soil erosion. Comply with Section 31 2500 Erosion Control.
- C. Ventilate enclosed areas to assist cure of materials, to dissipate humidity, and to prevent accumulation of dust, fumes, vapors, or gases.
- D. Dust Control: Execute work by methods to minimize raising dust from construction operations. Provide positive means to prevent air-borne dust from dispersing into atmosphere and over adjacent property.
- E. Erosion and Sediment Control: Plan and execute work by methods to control surface drainage from cuts and fills, from borrow and waste disposal areas. Prevent erosion and sedimentation.
  - 1. Comply with applicable local and State ordinances and codes.
  - 2. Develop and submit to authorities having jurisdiction written erosion control plan, if applicable.
  - 3. Minimize amount of bare soil exposed at one time.
- F. Pollution Control: Provide methods, means, and facilities to prevent contamination of soil, water, and atmosphere from discharge of noxious, toxic substances, and pollutants produced by construction operations. Comply with federal, state, and local regulations.

#### **1.06 COORDINATION**

- A. Coordinate scheduling, submittals, and work of the various sections of the Project Manual to ensure efficient and orderly sequence of installation of interdependent construction elements, with provisions for accommodating items installed later.
- B. Notify affected utility companies and comply with their requirements.
- C. Verify that utility requirements and characteristics of new operating equipment are compatible with building utilities. Coordinate work of various sections having interdependent responsibilities for installing, connecting to, and placing in service, such equipment.
- D. Coordinate space requirements, supports, and installation of mechanical and electrical work that are indicated diagrammatically on drawings. Follow routing indicated for pipes, ducts, and conduit, as closely as practicable; place runs parallel with lines of building. Utilize spaces efficiently to maximize accessibility for other installations, for maintenance, and for repairs.
- E. In finished areas except as otherwise indicated, conceal pipes, ducts, and wiring within the construction. Coordinate locations of fixtures and outlets with finish elements.
- F. Coordinate completion and clean-up of work of separate sections.

- G. After Owner occupancy of premises, coordinate access to site for correction of defective work and work not in accordance with Contract Documents, to minimize disruption of Owner's activities.

## **PART 2 PRODUCTS**

### **2.01 PATCHING MATERIALS**

- A. New Materials: As specified in product sections; match existing products and work for patching and extending work.
- B. Type and Quality of Existing Products: Determine by inspecting and testing products where necessary, referring to existing work as a standard.
- C. Product Substitution: For any proposed change in materials, submit request for substitution described in Section 016000 - Product Requirements.

## **PART 3 EXECUTION**

### **3.01 EXAMINATION**

- A. Verify that existing site conditions and substrate surfaces are acceptable for subsequent work. Start of work means acceptance of existing conditions.
- B. Verify that existing substrate is capable of structural support or attachment of new work being applied or attached.
- C. Examine and verify specific conditions described in individual specification sections.
- D. Take field measurements before confirming product orders or beginning fabrication, to minimize waste due to over-ordering or misfabrication.
- E. Verify that utility services are available, of the correct characteristics, and in the correct locations.
- F. Prior to Cutting: Examine existing conditions prior to commencing work, including elements subject to damage or movement during cutting and patching. After uncovering existing work, assess conditions affecting performance of work. Beginning of cutting or patching means acceptance of existing conditions.

### **3.02 PREPARATION**

- A. Clean substrate surfaces prior to applying next material or substance.
- B. Seal cracks or openings of substrate prior to applying next material or substance.
- C. Apply manufacturer required or recommended substrate primer, sealer, or conditioner prior to applying any new material or substance in contact or bond.

### **3.03 PREINSTALLATION MEETINGS**

- A. When required in individual specification sections, convene a preinstallation meeting at the site prior to commencing work of the section.
- B. Require attendance of parties directly affecting, or affected by, work of the specific section.
- C. Notify Architect seven days in advance of meeting date.
- D. Prepare agenda and preside at meeting:
  - 1. Review conditions of examination, preparation and installation procedures.
  - 2. Review coordination with related work.
- E. Record minutes and distribute copies within two days after meeting to participants, with two copies to Architect, Owner, participants, and those affected by decisions made.

### **3.04 LAYING OUT THE WORK**

- A. Verify locations of survey control points prior to starting work.
- B. Promptly notify Architect of any discrepancies discovered.
- C. Contractor shall locate and protect survey control and reference points.
- D. Control datum for survey is that indicated on drawings.

- E. Protect survey control points prior to starting site work; preserve permanent reference points during construction.
- F. Replace dislocated survey control points based on original survey control. Make no changes without prior written notice to Architect.
- G. Utilize recognized engineering survey practices.
- H. Establish elevations, lines and levels. Locate and lay out by instrumentation and similar appropriate means:
  1. Site improvements including pavements; stakes for grading, fill and topsoil placement; utility locations, slopes, and invert elevations.
  2. Grid or axis for structures.
  3. Building foundation, column locations, ground floor elevations.
- I. Periodically verify layouts by same means.
- J. Maintain a complete and accurate log of control and survey work as it progresses.

### **3.05 GENERAL INSTALLATION REQUIREMENTS**

- A. Install products as specified in individual sections, in accordance with manufacturer's instructions and recommendations, and so as to avoid waste due to necessity for replacement.
- B. Make vertical elements plumb and horizontal elements level, unless otherwise indicated.
- C. Install equipment and fittings plumb and level, neatly aligned with adjacent vertical and horizontal lines, unless otherwise indicated.
- D. Make consistent texture on surfaces, with seamless transitions, unless otherwise indicated.
- E. Make neat transitions between different surfaces, maintaining texture and appearance.

### **3.06 ALTERATIONS**

- A. Drawings showing existing construction and utilities are based on the best information available. Do not rely on drawings for locations of existing site improvements.
  1. Verify that construction and utility arrangements are as indicated.
  2. Report discrepancies to Architect before disturbing existing installation.
  3. Beginning of alterations work constitutes acceptance of existing conditions.
- B. Maintain weatherproof exterior building enclosure except for interruptions required for replacement or modifications; take care to prevent water and humidity damage.
  1. Where openings in exterior enclosure exist, provide construction to make exterior enclosure weatherproof.
  2. Insulate existing ducts or pipes that are exposed to outdoor ambient temperatures by alterations work.
- C. Remove existing work as indicated and as required to accomplish new work.
  1. Remove rotted wood, corroded metals, and deteriorated masonry and concrete; replace with new construction specified.
  2. Remove items indicated on drawings.
  3. Relocate items indicated on drawings.
  4. Where new surface finishes are to be applied to existing work, perform removals, patch, and prepare existing surfaces as required to receive new finish; remove existing finish if necessary for successful application of new finish.
  5. Where new surface finishes are not specified or indicated, patch holes and damaged surfaces to match adjacent finished surfaces as closely as possible.
- D. Services (Including but not limited to HVAC, Plumbing, Electrical, and Telecommunications): Remove, relocate, and extend existing systems to accommodate new construction.
  1. Maintain existing active systems that are to remain in operation; maintain access to equipment and operational components; if necessary, modify installation to allow access or provide access panel.
  2. Where existing systems or equipment are not active and Contract Documents require reactivation, put back into operational condition; repair supply, distribution, and equipment

- as required.
- 3. Verify that abandoned services serve only abandoned facilities.
- 4. Remove abandoned pipe, ducts, conduits, and equipment , including those above accessible ceilings; remove back to source of supply where possible, otherwise cap stub and tag with identification; patch holes left by removal using materials specified for new construction.
- E. Protect existing work to remain.
  - 1. Prevent movement of structure; provide shoring and bracing if necessary.
  - 2. Perform cutting to accomplish removals neatly and as specified for cutting new work.
  - 3. Repair adjacent construction and finishes damaged during removal work.
- F. Adapt existing work to fit new work: Make as neat and smooth transition as possible.
  - 1. When existing finished surfaces are cut so that a smooth transition with new work is not possible, terminate existing surface along a straight line at a natural line of division and make recommendation to Architect.
- G. Patching: Where the existing surface is not indicated to be refinished, patch to match the surface finish that existed prior to cutting. Where the surface is indicated to be refinished, patch so that the substrate is ready for the new finish.
- H. Refinish existing surfaces as indicated:
  - 1. Where rooms or spaces are indicated to be refinished, refinish all visible existing surfaces to remain to the specified condition for each material, with a neat transition to adjacent finishes.
  - 2. If mechanical or electrical work is exposed accidentally during the work, re-cover and refinish to match.
- I. Clean existing systems and equipment.
- J. Remove demolition debris and abandoned items from alterations areas and dispose of off-site; do not burn or bury.
- K. Do not begin new construction in alterations areas before demolition is complete.
- L. Comply with all other applicable requirements of this section.

### **3.07 CUTTING AND PATCHING**

- A. Whenever possible, execute the work by methods that avoid cutting or patching.
- B. See Alterations article above for additional requirements.
- C. Perform whatever cutting and patching is necessary to:
  - 1. Complete the work.
  - 2. Fit products together to integrate with other work.
  - 3. Provide openings for penetration of mechanical, electrical, and other services.
  - 4. Match work that has been cut to adjacent work.
  - 5. Repair areas adjacent to cuts to required condition.
  - 6. Repair new work damaged by subsequent work.
  - 7. Remove samples of installed work for testing when requested.
  - 8. Remove and replace defective and non-complying work.
- D. Execute cutting and patching including excavation and fill to complete the work, to uncover work in order to install improperly sequenced work, to remove and replace defective or non-conforming work, to remove samples of installed work for testing when requested, to provide openings in the work for penetration of mechanical and electrical work, to execute patching to complement adjacent work, and to fit products together to integrate with other work.
- E. Execute work by methods that avoid damage to other work and that will provide appropriate surfaces to receive patching and finishing. In existing work, minimize damage and restore to original condition.
- F. Employ original installer to perform cutting for weather exposed and moisture resistant elements, and sight exposed surfaces.

- G. Cut rigid materials using masonry saw or core drill. Pneumatic tools not allowed without prior approval.
- H. Restore work with new products in accordance with requirements of Contract Documents.
- I. Fit work air tight to pipes, sleeves, ducts, conduit, and other penetrations through surfaces.
- J. At penetrations of fire rated walls, partitions, ceiling, or floor construction, completely seal voids with fire rated material in accordance with Section 078400, to full thickness of the penetrated element.
- K. Patching:
  - 1. Finish patched surfaces to match finish that existed prior to patching. On continuous surfaces, refinish to nearest intersection or natural break. For an assembly, refinish entire unit.
  - 2. Match color, texture, and appearance.
  - 3. Repair patched surfaces that are damaged, lifted, discolored, or showing other imperfections due to patching work. If defects are due to condition of substrate, repair substrate prior to repairing finish.
- L. Refinish surfaces to match adjacent finish. For continuous surfaces, refinish to nearest intersection or natural break. For an assembly, refinish entire unit.
- M. Make neat transitions. Patch work to match adjacent work in texture and appearance. Where new work abuts or aligns with existing, perform a smooth and even transition.
- N. Patch or replace surfaces that are damaged, lifted, discolored, or showing other imperfections due to patching work. Repair substrate prior to patching finish. Finish patches to produce uniform finish and texture over entire area. When finish cannot be matched, refinish entire surface to nearest intersections.

### **3.08 PROGRESS CLEANING**

- A. Maintain areas free of waste materials, debris, and rubbish. Maintain site in a clean and orderly condition.
- B. Remove debris and rubbish from pipe chases, plenums, attics, crawl spaces, and other closed or remote spaces, prior to enclosing the space.
- C. Broom and vacuum clean interior areas prior to start of surface finishing, and continue cleaning to eliminate dust.
- D. Collect and remove waste materials, debris, and trash/rubbish from site periodically and dispose off-site; do not burn or bury.

### **3.09 PROTECTION OF INSTALLED WORK**

- A. Protect installed work from damage by construction operations.
- B. Provide special protection where specified in individual specification sections.
- C. Provide temporary and removable protection for installed products. Control activity in immediate work area to prevent damage.
- D. Provide protective coverings at walls, projections, jambs, sills, and soffits of openings.
- E. Protect finished floors, stairs, and other surfaces from traffic, dirt, wear, damage, or movement of heavy objects, by protecting with durable sheet materials.
- F. Protect work from spilled liquids. If work is exposed to spilled liquids, immediately remove protective coverings, dry out work, and replace protective coverings.
- G. Prohibit traffic or storage upon waterproofed or roofed surfaces. If traffic or activity is necessary, obtain recommendations for protection from waterproofing or roofing material manufacturer.
- H. Prohibit traffic from landscaped areas.
- I. Remove protective coverings when no longer needed; reuse or recycle coverings if possible.

### **3.10 SYSTEM STARTUP**

- A. Coordinate schedule for start-up of various equipment and systems.
- B. Notify Architect and Owner seven days prior to start-up of each item.
- C. Verify that each piece of equipment or system has been checked for proper lubrication, drive rotation, belt tension, control sequence, and for conditions that may cause damage.
- D. Verify tests, meter readings, and specified electrical characteristics agree with those required by the equipment or system manufacturer.
- E. Verify that wiring and support components for equipment are complete and tested.
- F. Execute start-up under supervision of applicable Contractor personnel and manufacturer's representative in accordance with manufacturers' instructions.
- G. When specified in individual specification Sections, require manufacturer to provide authorized representative to be present at site to inspect, check, and approve equipment or system installation prior to start-up, and to supervise placing equipment or system in operation.
- H. Submit a written report that equipment or system has been properly installed and is functioning correctly.

### **3.11 DEMONSTRATION AND INSTRUCTION**

- A. Demonstrate start-up, operation, control, adjustment, trouble-shooting, servicing, maintenance, and shutdown of each item of equipment at scheduled time, at equipment location.
- B. For equipment or systems requiring seasonal operation, perform demonstration for other season within twelve months.
- C. Provide a qualified manufacturer's representative who is knowledgeable about the Project to perform demonstration and instruction of Owner's personnel.
- D. The amount of time required for instruction on each item of equipment and system is that specified in individual sections.

### **3.12 ADJUSTING**

- A. Adjust operating products and equipment to ensure smooth and unhindered operation.
- B. Testing, adjusting, and balancing HVAC systems: See Section 230593 - Testing, Adjusting, and Balancing for HVAC.

### **3.13 FINAL CLEANING**

- A. Use cleaning materials that are nonhazardous.
- B. Clean interior and exterior glass, surfaces exposed to view; remove temporary labels, stains and foreign substances, polish transparent and glossy surfaces, vacuum carpeted and soft surfaces.
- C. Remove all labels that are not permanent. Do not paint or otherwise cover fire test labels or nameplates on mechanical and electrical equipment.
- D. Clean equipment and fixtures to a sanitary condition with cleaning materials appropriate to the surface and material being cleaned.
- E. Clean filters of operating equipment.
- F. Clean debris from roofs, gutters, downspouts, scuppers, overflow drains, area drains, and drainage systems.
- G. Clean site; sweep paved areas, rake clean landscaped surfaces.
- H. Remove waste, surplus materials, trash/rubbish, and construction facilities from the site; dispose of in legal manner; do not burn or bury.

### **3.14 CLOSEOUT PROCEDURES**

- A. Make submittals that are required by governing or other authorities.
  - 1. Provide copies to Architect.

- B. Accompany Project Coordinator on preliminary inspection to determine items to be listed for completion or correction in the Contractor's Correction Punch List for Contractor's Notice of Substantial Completion.
- C. Notify Architect when work is considered ready for Substantial Completion.
  - 1. Preliminary Procedures: Before requesting final verification for determining date of Substantial Completion, complete the following. List items below that are incomplete in request.
    - a. Prepare a list of items to be completed and corrected (punch list), the value of items on the list, and reasons why the Work is not complete.
    - b. Deliver tools, spare parts, extra materials, and similar items to location designated by Owner. Label with manufacturer's name and model number where applicable.
    - c. Terminate and remove temporary facilities from Project site, along with mockups, construction tools, and similar elements.
  - 2. Inspection: Submit a written request for inspection for Substantial Completion. On receipt of request, Architect will either proceed with inspection or notify Contractor of unfulfilled requirements. Architect will prepare the Certificate of Substantial Completion after inspection or will notify Contractor of items, either on Contractor's list or additional items identified by Architect, that must be completed or corrected before certificate will be issued.
    - a. Re-inspection: Request re-inspection when the Work identified in previous inspections as incomplete is completed or corrected.
    - b. Results of completed inspection will form the basis of requirements for Final Completion.
- D. Submit written certification containing Contractor's Correction Punch List, that Contract Documents have been reviewed, work has been inspected, and that work is complete in accordance with Contract Documents and ready for Architect's Substantial Completion inspection.
- E. Conduct Substantial Completion inspection and create Final Correction Punch List containing Architect's and Contractor's comprehensive list of items identified to be completed or corrected and submit to Architect.
- F. Correct items of work listed in Final Correction Punch List and comply with requirements for access to Owner-occupied areas.
- G. Notify Architect when work is considered finally complete and ready for Architect's Substantial Completion final inspection.
  - 1. Preliminary Procedures: Before requesting final verification of compliance for determining date of Final Completion, complete the following:
    - a. Submit a final Application for Payment according to Division 1 Section "Payment Procedures."
    - b. Submit certified copy of Architect's Substantial Completion inspection list of items to be completed or corrected (punch list), endorsed and dated by Architect. The certified copy of the list shall state that each item has been completed or otherwise resolved for acceptance.
    - c. Submit evidence of final, continuing insurance coverage complying with insurance requirements.
    - d. Submit a statement, accounting for changes to the Contract Sum.
    - e. Submit consent of surety to final payment.
    - f. Submit waivers of liens from subcontractors and material suppliers.
    - g. Submit record drawings, maintenance manuals, final project photographs, damage or settlement surveys, property surveys and similar final record information.
    - h. Submit sworn affidavit stating that no material containing asbestos or polychlorinated biphenyl (PCB) were used or installed under this project.
    - i. Complete final cleanup requirements, including touchup painting.
- H. Complete items of work determined by Architect listed in executed Certificate of Substantial Completion.



### **3.15 MAINTENANCE**

- A. Provide service and maintenance of components indicated in specification sections.
- B. Maintenance Period: As indicated in specification sections or, if not indicated, not less than one year from the Date of Substantial Completion or the length of the specified warranty, whichever is longer.
- C. Furnish service and maintenance of components indicated in specification sections during the warranty period.
- D. Examine system components at a frequency consistent with reliable operation. Clean, adjust, and lubricate as required.
- E. Include systematic examination, adjustment, and lubrication of components. Repair or replace parts whenever required. Use parts produced by the manufacturer of the original component.
- F. Maintenance service shall not be assigned or transferred to any agent or subcontractor without prior written consent of the Owner.

**END OF SECTION**

**SECTION 017800  
CLOSEOUT SUBMITTALS**

**PART 1 GENERAL**

**1.01 SECTION INCLUDES**

- A. Project record documents.
- B. Closeout Release Documents.
- C. Operation and maintenance data.
- D. Warranties and bonds.

**1.02 RELATED REQUIREMENTS**

- A. Section 013000 - Administrative Requirements: Submittals procedures, shop drawings, product data, and samples.
- B. Section 017000 - Execution and Closeout Requirements: Contract closeout procedures.
- C. Individual Product Sections: Specific requirements for operation and maintenance data.
- D. Individual Product Sections: Warranties required for specific products or Work.

**1.03 SUBMITTALS**

- A. Project Record Documents: Submit documents to Architect with claim for final Application for Payment.
  - 1. Submit one copy of completed documents 15 days prior to final inspection. This copy will be reviewed and returned after final inspection, with Architect comments. Revise content of all document sets as required prior to final submission.
  - 2. Final Submission: Submit one full size set of revised final documents in final form within 10 days after final inspection.
    - a. Submit one electronic set in the form of pdf documents.
- B. Closeout Release Documents:
  - 1. Asbestos and or polychlorinated biphenyl (PCB) Affidavit. Each contractor shall furnish to the Owner and Architect a sworn affidavit stating that materials used under this contract did not contain asbestos or polychlorinated biphenyl (PCB).
- C. Operation and Maintenance Data:
  - 1. Submit digital PDF copies of preliminary draft or proposed formats and outlines of contents before start of Work. Architect will review draft and return one copy with comments.
  - 2. For equipment, or component parts of equipment put into service during construction and operated by Owner, submit completed documents within ten days after acceptance.
  - 3. Submit one copy of completed documents 15 days prior to final inspection. This copy will be reviewed and returned after final inspection, with Architect comments. Revise content of all document sets as required prior to final submission.
  - 4. Submit one (1) digital and two (2) hard copy sets of revised final documents in final form within 10 days after final inspection.
- D. Warranties and Bonds:
  - 1. For equipment or component parts of equipment put into service during construction with Owner's permission, submit documents within 10 days after acceptance.
  - 2. Make other submittals within 10 days after Date of Substantial Completion, prior to final Application for Payment.
  - 3. For items of Work for which acceptance is delayed beyond Date of Substantial Completion, submit within 10 days after acceptance, listing the date of acceptance as the beginning of the warranty period.

## **PART 2 PRODUCTS - NOT USED**

## **PART 3 EXECUTION**

### **3.01 PROJECT RECORD DOCUMENTS**

- A. Maintain on site one set of the following record documents; record actual revisions to the Work:
  - 1. Drawings.
  - 2. Specifications.
  - 3. Addenda.
  - 4. Change Orders and other modifications to the Contract.
  - 5. Reviewed shop drawings, product data, and samples.
  - 6. Manufacturer's instruction for assembly, installation, and adjusting.
- B. Ensure entries are complete and accurate, enabling future reference by Owner.
- C. Store record documents separate from documents used for construction.
- D. Record information concurrent with construction progress.
- E. Specifications: Legibly mark and record at each product section description of actual products installed, including the following:
  - 1. Changes made by Addenda and modifications.
- F. Record Drawings and Shop Drawings: Legibly mark each item to record actual construction including:
  - 1. Field changes of dimension and detail.
  - 2. Details not on original Contract drawings.

### **3.02 OPERATION AND MAINTENANCE DATA**

- A. Source Data: For each product or system, list names, addresses and telephone numbers of Subcontractors and suppliers, including local source of supplies and replacement parts.
- B. Product Data: Mark each sheet to clearly identify specific products and component parts, and data applicable to installation. Delete inapplicable information.
- C. Drawings: Supplement product data to illustrate relations of component parts of equipment and systems, to show control and flow diagrams. Do not use Project Record Documents as maintenance drawings.
- D. Typed Text: As required to supplement product data. Provide logical sequence of instructions for each procedure, incorporating manufacturer's instructions.

### **3.03 OPERATION AND MAINTENANCE DATA FOR MATERIALS AND FINISHES**

- A. For Each Product, Applied Material, and Finish:
- B. Instructions for Care and Maintenance: Manufacturer's recommendations for cleaning agents and methods, precautions against detrimental cleaning agents and methods, and recommended schedule for cleaning and maintenance.
- C. Where additional instructions are required, beyond the manufacturer's standard printed instructions, have instructions prepared by personnel experienced in the operation and maintenance of the specific products.

### **3.04 OPERATION AND MAINTENANCE DATA FOR EQUIPMENT AND SYSTEMS**

- A. For Each Item of Equipment and Each System:
  - 1. Description of unit or system, and component parts.
  - 2. Identify function, normal operating characteristics, and limiting conditions.
  - 3. Include performance curves, with engineering data and tests.
  - 4. Complete nomenclature and model number of replaceable parts.
- B. Where additional instructions are required, beyond the manufacturer's standard printed instructions, have instructions prepared by personnel experienced in the operation and maintenance of the specific products.

- C. Panelboard Circuit Directories: Provide electrical service characteristics, controls, and communications; typed.
- D. Operating Procedures: Include start-up, break-in, and routine normal operating instructions and sequences. Include regulation, control, stopping, shut-down, and emergency instructions. Include summer, winter, and any special operating instructions.
- E. Maintenance Requirements: Include routine procedures and guide for preventative maintenance and trouble shooting; disassembly, repair, and reassembly instructions; and alignment, adjusting, balancing, and checking instructions.
- F. Provide servicing and lubrication schedule, and list of lubricants required.
- G. Include manufacturer's printed operation and maintenance instructions.
- H. Include sequence of operation by controls manufacturer.
- I. Provide original manufacturer's parts list, illustrations, assembly drawings, and diagrams required for maintenance.
- J. Provide control diagrams by controls manufacturer as installed.
- K. Provide charts of valve tag numbers, with location and function of each valve, keyed to flow and control diagrams.
- L. Provide list of original manufacturer's spare parts, current prices, and recommended quantities to be maintained in storage.
- M. Include test and balancing reports.
- N. Additional Requirements: As specified in individual product specification sections.

### **3.05 ASSEMBLY OF OPERATION AND MAINTENANCE MANUALS**

- A. Assemble operation and maintenance data into durable manuals for Owner's personnel use, with data arranged in the same sequence as, and identified by, the specification sections.
- B. Where systems involve more than one specification section, provide separate tabbed divider for each system.
- C. Prepare instructions and data by personnel experienced in maintenance and operation of described products.
- D. Prepare data in the form of an instructional manual.
- E. Binders: Commercial quality, 8-1/2 by 11 inch (216 by 280 mm) three D side ring binders with durable plastic covers; 2 inch (50 mm) maximum ring size. When multiple binders are used, correlate data into related consistent groupings.
- F. Cover: Identify each binder with typed or printed title OPERATION AND MAINTENANCE INSTRUCTIONS; identify title of Project; identify subject matter of contents.
- G. Project Directory: Title and address of Project; names, addresses, and telephone numbers of Architect, Consultants, Contractor and subcontractors, with names of responsible parties.
- H. Tables of Contents: List every item separated by a divider, using the same identification as on the divider tab; where multiple volumes are required, include all volumes Tables of Contents in each volume, with the current volume clearly identified.
- I. Dividers: Provide tabbed dividers for each separate product and system; identify the contents on the divider tab; immediately following the divider tab include a description of product and major component parts of equipment.
- J. Text: Manufacturer's printed data, or typewritten data on 24 pound paper.
- K. Drawings: Provide with reinforced punched binder tab. Bind in with text; fold larger drawings to size of text pages.

### **3.06 WARRANTIES AND BONDS**

- A. Obtain warranties and bonds, executed in duplicate by responsible Subcontractors, suppliers, and manufacturers, within 10 days after completion of the applicable item of work. Except for

items put into use with Owner's permission, leave date of beginning of time of warranty until Date of Substantial completion is determined.

- B. Verify that documents are in proper form, contain full information, and are notarized.
- C. Co-execute submittals when required.
- D. Retain warranties and bonds until time specified for submittal.

**END OF SECTION**

## **SECTION 024100 DEMOLITION**

### **PART 1 GENERAL**

#### **1.01 SECTION INCLUDES**

- A. Selective demolition of built site elements.
- B. Selective demolition of building elements for alteration purposes.

#### **1.02 REFERENCE STANDARDS**

- A. 29 CFR 1926 - Safety and Health Regulations for Construction; Current Edition.

#### **1.03 QUALITY ASSURANCE**

- A. The Contractor shall comply with all municipal, county, state and federal ordinances regarding the disposal or rubble, scrap metal, and refuse.
- B. Accomplish all demolition work so there is no injury to any persons and no damage to adjacent structures or property. All demolition methods shall be in full compliance with municipal, county, state, and federal ordinances. Demolition work shall comply with the requirements of the Occupational Safety & Health Administration (OSHA)
- C. Demolition procedures shall be developed by the Contractor. The procedures shall provide for safe conduct of the work, protection of property which is to remain undisturbed, including the installation of dust barriers at occupied areas of buildings, and coordination with other work in progress. The procedures shall include a detailed description of the methods and equipment to be used for each operation and sequence of operations.

#### **1.04 CARE OF EXISTING STRUCTURES AND PROPERTY**

- A. All poles, fences, signs, mailboxes, sewer, gas, water, or other pipes, wires, conduits, culverts, inlets, manholes, buildings, structures and property in the proximity or any excavation shall be supported and protected from damage by the Contractor during construction.
- B. Wherever sewer, gas, water or other pipes or conduits cross the excavation, the Contractor shall support said pipes and conduits without damage to them and without interrupting their use during the progress of the Work. The manner of supporting such pipes, ect., shall be subject to review by the engineer.
- C. All property shall be thoroughly cleaned of all surplus materials, earth and rubbish placed thereon by the Contractor.

#### **1.05 EXISTING UNDERGROUND STRUCTURES**

- A. The plans show the location of utilities based upon the best available information, however, the Engineer does not accept any responsibility for the accuracy of this information nor does he guarantee that all utilities within the work area are shown.
- B. The Contractor shall notify the appropriate utility companies prior to the start of demolition.
  - 1. The Contractor shall coordinate all utility companies locating of any existing underground utilities and structures within the site limits.
  - 2. The Contractor, prior to the start of demolition, shall verify the location of any existing underground utilities and structures within the site limits. It is the Contractor's responsibility to make any and all exploratory investigation which may be necessary to verify or locate the utility pipe, wires, structures and appurtenances of others. The Contractor shall notify the Engineer of any conflicts between the location called for in the information furnished and the actual location of any existing underground utilities or structures. Any conflicts found shall be recorded as directed by the Engineer.

### **PART 2 PRODUCTS**

#### **2.01 MATERIALS**

- A. Fill Material: As specified in Section 312323 - Fill.
- B. Materials used in the replacement or repair of existing work to remain shall be equal to the materials used in the existing work when it was new.

- C. Temporary materials such as barricades, fencing and other items shall conform to the requirements of other sections of these Specifications.

### **PART 3 EXECUTION**

#### **3.01 SCOPE**

- A. Scope of work as indicated on drawings.
- B. Remove other items indicated, for salvage, relocation, and recycling.
- C. Fill excavations, open pits, and holes in ground areas generated as result of removals, using specified fill; compact fill as specified in Section 312200.

#### **3.02 PAVEMENT AND WALKS**

- A. Use methods to remove pavement, sidewalks, curbs and gutters that will assure breaks at pavement, sidewalks, curbs and gutters not removed are along straight lines. The faces of the remaining pavement, sidewalk, curb and gutter faces shall be approximately vertical.
- B. Completely remove pavement, sidewalks, curbs and gutters which are indicated on the Drawings to be removed.

#### **3.03 UTILITIES AND PIPING**

- A. Completely remove other piping, conduit and wiring which are designated to be removed or demolished.
- B. Underground piping, conduit and wiring which are to be abandoned and do not interfere with new work may be left in place, unless otherwise shown on the Drawings. Plug cut ends of underground piping to be abandoned. Do not leave abandoned branches of piping and wiring "live." Isolate abandoned branches by closing branch valve at main or by disconnecting branch at main. Plug active branch at isolating valve or point of disconnection.
- C. Properly disconnect and plug utility services to structures which are completely demolished.

#### **3.04 BACKFILL**

- A. Backfill excavations beneath new structures, buildings, piping and other new work as specified in section 31 2000, Earthwork for Site.
- B. Backfill excavations, which will not be beneath new structures, buildings, piping or other new work as specified in this paragraph.
  - 1. Backfill excavations more than three feet deep or more than five cubic yards in volume as specified in Section 31 2000, Earthwork for Site.

#### **3.05 GENERAL PROCEDURES AND PROJECT CONDITIONS**

- A. Comply with other requirements specified in Section 017000.
- B. Comply with applicable codes and regulations for demolition operations and safety of adjacent structures and the public.
  - 1. Obtain required permits.
  - 2. Comply with applicable requirements of NFPA 241.
  - 3. Use of explosives is not permitted.
  - 4. Take precautions to prevent catastrophic or uncontrolled collapse of structures to be removed; do not allow worker or public access within range of potential collapse of unstable structures.
  - 5. Provide, erect, and maintain temporary barriers and security devices.
  - 6. Use physical barriers to prevent access to areas that could be hazardous to workers or the public.
  - 7. Conduct operations to minimize effects on and interference with adjacent structures and occupants.
  - 8. Do not close or obstruct roadways or sidewalks without permit.
  - 9. Conduct operations to minimize obstruction of public and private entrances and exits; do not obstruct required exits at any time; protect persons using entrances and exits from removal operations.

- 10. Obtain written permission from owners of adjacent properties when demolition equipment will traverse, infringe upon or limit access to their property.
- C. Do not begin removal until receipt of notification to proceed from Owner.
- D. Do not begin removal until built elements to be salvaged or relocated have been removed.
- E. Protect existing structures and other elements that are not to be removed.
  - 1. Provide bracing and shoring.
  - 2. Prevent movement or settlement of adjacent structures.
  - 3. Stop work immediately if adjacent structures appear to be in danger.
- F. If hazardous materials are discovered during removal operations, stop work and notify Architect and Owner; hazardous materials include regulated asbestos containing materials, lead, PCB's, and mercury.
- G. Perform demolition in a manner that maximizes salvage and recycling of materials.
  - 1. Dismantle existing construction and separate materials.
  - 2. Set aside reusable, recyclable, and salvageable materials; store and deliver to collection point or point of reuse.
- H. Partial Removal of Paving and Curbs: Neatly saw cut at right angle to surface.

### **3.06 EXISTING UTILITIES**

- A. Coordinate work with utility companies; notify before starting work and comply with their requirements; obtain required permits.
- B. Protect existing utilities to remain from damage.
- C. Do not disrupt public utilities without permit from authority having jurisdiction.
- D. Locate and mark utilities to remain; mark using highly visible tags or flags, with identification of utility type; protect from damage due to subsequent construction, using substantial barricades if necessary.
- E. Remove exposed piping, valves, meters, equipment, supports, and foundations of disconnected and abandoned utilities.
- F. Prepare building demolition areas by disconnecting and capping utilities outside the demolition zone; identify and mark utilities to be subsequently reconnected, in same manner as other utilities to remain.

### **3.07 SELECTIVE DEMOLITION FOR ALTERATIONS**

- A. Drawings showing existing construction and utilities are based on casual field observation and existing record documents only.
  - 1. Report discrepancies to Architect before disturbing existing installation.
  - 2. Beginning of demolition work constitutes acceptance of existing conditions that would be apparent upon examination prior to starting demolition.
- B. Remove existing work as indicated and as required to accomplish new work.
  - 1. Remove items indicated on drawings.
- C. Protect existing work to remain.
  - 1. Prevent movement of structure; provide shoring and bracing if necessary.
  - 2. Perform cutting to accomplish removals neatly and as specified for cutting new work.
  - 3. Repair adjacent construction and finishes damaged during removal work.
  - 4. Patch as specified for patching new work.

### **3.08 DEBRIS AND WASTE REMOVAL**

- A. Remove debris, junk, and trash from site.
- B. Leave site in clean condition, ready for subsequent work.
- C. Clean up spillage and wind-blown debris from public and private lands.

**END OF SECTION**



**SECTION 033000  
CAST-IN-PLACE CONCRETE**

**PART 1 GENERAL**

**1.01 SECTION INCLUDES**

- A. Concrete formwork.
- B. Concrete reinforcement.
- C. Joint devices associated with concrete work.
- D. Miscellaneous concrete elements, including equipment pads, equipment pits, light pole bases, flagpole bases, thrust blocks, and manholes.
- E. Concrete curing.

**1.02 REFERENCE STANDARDS**

- A. ACI 117 - Specification for Tolerances for Concrete Construction and Materials; 2010 (Reapproved 2015).
- B. ACI 211.1 - Selecting Proportions for Normal-Density and High Density-Concrete - Guide; 2022.
- C. ACI 301 - Specifications for Concrete Construction; 2020.
- D. ACI 304R - Guide for Measuring, Mixing, Transporting, and Placing Concrete; 2000 (Reapproved 2009).
- E. ACI 305R - Guide to Hot Weather Concreting; 2020.
- F. ACI 308R - Guide to External Curing of Concrete; 2016.
- G. ACI 318 - Building Code Requirements for Structural Concrete; 2019 (Reapproved 2022).
- H. ACI 347R - Guide to Formwork for Concrete; 2014 (Reapproved 2021).
- I. ASTM A1064/A1064M - Standard Specification for Carbon-Steel Wire and Welded Wire Reinforcement, Plain and Deformed, for Concrete; 2022.
- J. ASTM C39/C39M - Standard Test Method for Compressive Strength of Cylindrical Concrete Specimens; 2023.
- K. ASTM C94/C94M - Standard Specification for Ready-Mixed Concrete; 2023.
- L. ASTM C109/C109M - Standard Test Method for Compressive Strength of Hydraulic Cement Mortars (Using 2-in. or [50 mm] Cube Specimens); 2021.
- M. ASTM C150/C150M - Standard Specification for Portland Cement; 2022.
- N. ASTM C171 - Standard Specification for Sheet Materials for Curing Concrete; 2020.
- O. ASTM C173/C173M - Standard Test Method for Air Content of Freshly Mixed Concrete by the Volumetric Method; 2023.
- P. ASTM C260/C260M - Standard Specification for Air-Entraining Admixtures for Concrete; 2010a (Reapproved 2016).
- Q. ASTM C1059/C1059M - Standard Specification for Latex Agents for Bonding Fresh to Hardened Concrete; 2021.
- R. ASTM E1155 - Standard Test Method for Determining FF Floor Flatness and FL Floor Levelness Numbers; 2020.

**1.03 SUBMITTALS**

- A. Mix Design: Submit proposed concrete mix design.
  - 1. Indicate proposed mix design complies with requirements of ACI 301, Section 4 - Concrete Mixtures.
  - 2. Indicate proposed mix design complies with requirements of ACI 318, Chapter 5 - Concrete Quality, Mixing and Placing.
- B. Test Reports: Submit report for each test or series of tests specified.

- C. Manufacturer's Installation Instructions: For concrete accessories, indicate installation procedures and interface required with adjacent construction.

#### **1.04 QUALITY ASSURANCE**

- A. Perform work of this section in accordance with ACI 301 and ACI 318.
- B. Follow recommendations of ACI 305R when concreting during hot weather.
- C. Follow recommendations of ACI 306R when concreting during cold weather.

#### **1.05 WARRANTY**

- A. See Section 017800 - Closeout Submittals for additional warranty requirements.

### **PART 2 PRODUCTS**

#### **2.01 FORMWORK**

- A. Formwork Design and Construction: Comply with guidelines of ACI 347R to provide formwork that will produce concrete complying with tolerances of ACI 117.
- B. Form Materials: Contractor's choice of standard products with sufficient strength to withstand hydrostatic head without distortion in excess of permitted tolerances.
  - 1. Form Facing for Exposed Finish Concrete: Contractor's choice of materials that will provide smooth, stain-free final appearance.
  - 2. Earth Cuts: Do not use earth cuts as forms for vertical surfaces. Natural rock formations that maintain a stable vertical edge may be used as side forms.
  - 3. Form Coating: Release agent that will not adversely affect concrete or interfere with application of coatings.

#### **2.02 REINFORCEMENT MATERIALS**

- A. Reinforcing Steel: ASTM A615/A615M, Grade 60 (60,000 psi) (420 MPa).
  - 1. Type: Deformed billet-steel bars.
  - 2. Finish: Unfinished, unless otherwise indicated.
- B. Reinforcement Accessories:
  - 1. Tie Wire: Annealed, minimum 16 gauge, 0.0508 inch (1.29 mm).
  - 2. Chairs, Bolsters, Bar Supports, Spacers: Sized and shaped for adequate support of reinforcement during concrete placement.
  - 3. Provide stainless steel, galvanized, plastic, or plastic coated steel components for placement within 1-1/2 inches (38 mm) of weathering surfaces.

#### **2.03 CONCRETE MATERIALS**

- A. Cement: ASTM C150/C150M, Type I - Normal Portland type.
  - 1. Acquire cement for entire project from same source.
- B. Fine and Coarse Aggregates: ASTM C33/C33M.

#### **2.04 ADMIXTURES**

- A. Do not use chemicals that will result in soluble chloride ions in excess of 0.1 percent by weight of cement.
- B. Air Entrainment Admixture: ASTM C260/C260M.

#### **2.05 ACCESSORY MATERIALS**

- A. Non-Shrink Cementitious Grout: Premixed compound consisting of non-metallic aggregate, cement, water reducing and plasticizing agents.

#### **2.06 BONDING AND JOINTING PRODUCTS**

- A. Latex Bonding Agent: Non-redispersable acrylic latex, complying with ASTM C1059/C1059M, Type II.
- B. Slab Isolation Joint Filler: 1/2 inch (13 mm) thick, height equal to slab thickness, with removable top section that will form 1/2 inch (13 mm) deep sealant pocket after removal.

## **2.07 CONCRETE MIX DESIGN**

- A. Proportioning Normal Weight Concrete: Comply with ACI 211.1 recommendations.
- B. Submit written report to Architect/Engineer of each proposed mix for each class of concrete at least 15 days prior to start of work. Do not begin concrete production until mixes have been reviewed by Architect/Engineer.
- C. Concrete Strength: Establish required average strength for each type of concrete on the basis of field experience or trial mixtures, as specified in ACI 301.
  - 1. For trial mixtures method, employ independent testing agency acceptable to Architect for preparing and reporting proposed mix designs.
- D. Admixtures: Add acceptable admixtures as recommended in ACI 211.1 and at rates recommended or required by manufacturer.
- E. Normal Weight Concrete, Interior Slabs on Grade: Proportion normal-weight concrete mix as follows:
  - 1. Compressive Strength, when tested in accordance with ASTM C39/C39M at 28 days: 3,000 pounds per square inch (20.7 MPa).
  - 2. Water-Cement Ratio: Maximum 40 percent by weight.
  - 3. Total Air Content: 4 percent, determined in accordance with ASTM C173/C173M.
  - 4. Maximum Slump: 3 inches (75 mm).
  - 5. Maximum Aggregate Size: 3/4 inch (19 mm).

## **2.08 MIXING**

- A. Transit Mixers: Comply with ASTM C94/C94M.
- B. Adding Water: If concrete arrives on-site with slump less than suitable for placement, do not add water that exceeds the maximum water-cement ratio or exceeds the maximum permissible slump.

## **PART 3 EXECUTION**

### **3.01 EXAMINATION**

- A. Verify lines, levels, and dimensions before proceeding with work of this section.

### **3.02 PREPARATION**

- A. Formwork: Comply with requirements of ACI 301. Design and fabricate forms to support all applied loads until concrete is cured, and for easy removal without damage to concrete.
- B. Verify that forms are clean and free of rust before applying release agent.
- C. Coordinate placement of embedded items with erection of concrete formwork and placement of form accessories.
- D. Where new concrete is to be bonded to previously placed concrete, prepare existing surface by cleaning and applying bonding agent in according to bonding agent manufacturer's instructions.
  - 1. Use latex bonding agent only for non-load-bearing applications.
- E. Interior Slabs on Grade: Install vapor retarder under interior slabs on grade. Comply with ASTM E1643. Lap joints minimum 6 inches (150 mm). Seal joints, seams and penetrations watertight with manufacturer's recommended products and follow manufacturer's written instructions. Repair damaged vapor retarder before covering.
  - 1. Vapor Retarder Over Granular Fill: Install compactible granular fill before placing vapor retarder as indicated on drawings. Do not use sand.

### **3.03 INSTALLING REINFORCEMENT AND OTHER EMBEDDED ITEMS**

- A. Comply with requirements of ACI 301. Clean reinforcement of loose rust and mill scale, and accurately position, support, and secure in place to achieve not less than minimum concrete coverage required for protection.
- B. Verify that anchors, seats, plates, reinforcement and other items to be cast into concrete are accurately placed, positioned securely, and will not interfere with concrete placement.

### **3.04 PLACING CONCRETE**

- A. Place concrete in accordance with ACI 304R.
- B. Maintain records of concrete placement. Record date, location, quantity, air temperature, and test samples taken.
- C. Ensure reinforcement, inserts, waterstops, embedded parts, and formed construction joint devices will not be disturbed during concrete placement.

### **3.05 SLAB JOINTING**

- A. Joint Filler Type: ASTM D1751 asphalt impregnated fiberboard or felt, 1/4" thick; tongue and groove profile
- B. Locate joints as indicated on drawings.
- C. Anchor joint fillers and devices to prevent movement during concrete placement.
- D. Isolation Joints: Use preformed joint filler with removable top section for joint sealant, total height equal to thickness of slab, set flush with top of slab.
- E. Saw Cut Contraction Joints: Saw cut joints before concrete begins to cool, within 4 to 12 hours after placing; use 3/16 inch (5 mm) thick blade and cut at least 1 inch (25 mm) deep but not less than one quarter (1/4) the depth of the slab.

### **3.06 CONCRETE FINISHING**

- A. Exposed Form Finish: Rub down or chip off and smooth fins or other raised areas 1/4 inch (6 mm) or more in height. Provide finish as follows:
  - 1. Smooth Rubbed Finish: Wet concrete and rub with carborundum brick or other abrasive, not more than 24 hours after form removal.

### **3.07 CURING AND PROTECTION**

- A. Comply with requirements of ACI 308R. Immediately after placement, protect concrete from premature drying, excessively hot or cold temperatures, and mechanical injury.
  - 1. Protect concrete footings from freezing.
- B. Maintain concrete with minimal moisture loss at relatively constant temperature for period necessary for hydration of cement and hardening of concrete.
  - 1. Normal concrete: Not less than three days.
- C. Surfaces Not in Contact with Forms:
  - 1. Final Curing: Begin after initial curing but before surface is dry.

### **3.08 FIELD QUALITY CONTROL**

- A. An independent testing agency will perform field quality control tests, as specified in Section 014000 - Quality Requirements.
  - 1. General Contractor to provide payment for testing procedure.
- B. Provide free access to concrete operations at project site and cooperate with appointed firm.
- C. Submit proposed mix design of each class of concrete to inspection and testing firm for review prior to commencement of concrete operations.
- D. Tests of concrete and concrete materials may be performed at any time to ensure compliance with specified requirements.

### **3.09 DEFECTIVE CONCRETE**

- A. Test Results: The testing agency shall report test results in writing to Architect and Contractor within 24 hours of test.
- B. Defective Concrete: Concrete not complying with required lines, details, dimensions, tolerances or specified requirements.
- C. Repair or replacement of defective concrete will be determined by the Project Manager. The cost of additional testing shall be borne by Contractor when defective concrete is identified.

- D. Do not patch, fill, touch-up, repair, or replace exposed concrete except upon express direction of Project Manager for each individual area.

**END OF SECTION**

**SECTION 042000  
UNIT MASONRY**

**PART 1 GENERAL**

**1.01 SECTION INCLUDES**

- A. Concrete block.
- B. Common brick.
- C. Mortar and grout.
- D. Reinforcement and anchorage.
- E. Flashings.
- F. Accessories.

**1.02 RELATED REQUIREMENTS**

- A. Section 055000 - Metal Fabrications: Loose steel lintels.
- B. Section 061000 - Rough Carpentry: Nailing strips built into masonry.
- C. Section 072100 - Thermal Insulation: Insulation for cavity spaces.
- D. Section 076200 - Sheet Metal Flashing and Trim: Through-wall masonry flashings.
- E. Section 079200 - Joint Sealants: Sealing control and expansion joints.

**1.03 REFERENCE STANDARDS**

- A. ASTM A153/A153M - Standard Specification for Zinc Coating (Hot-Dip) on Iron and Steel Hardware; 2023.
- B. ASTM A641/A641M - Standard Specification for Zinc-Coated (Galvanized) Carbon Steel Wire; 2019.
- C. ASTM A951/A951M - Standard Specification for Steel Wire for Masonry Joint Reinforcement; 2022.
- D. ASTM A1064/A1064M - Standard Specification for Carbon-Steel Wire and Welded Wire Reinforcement, Plain and Deformed, for Concrete; 2022.
- E. ASTM C90 - Standard Specification for Loadbearing Concrete Masonry Units; 2023.
- F. ASTM C91/C91M - Standard Specification for Masonry Cement; 2023.
- G. ASTM C129 - Standard Specification for Nonloadbearing Concrete Masonry Units; 2023.
- H. ASTM C144 - Standard Specification for Aggregate for Masonry Mortar; 2018.
- I. ASTM C150/C150M - Standard Specification for Portland Cement; 2022.
- J. ASTM C207 - Standard Specification for Hydrated Lime for Masonry Purposes; 2018.
- K. ASTM C216 - Standard Specification for Facing Brick (Solid Masonry Units Made from Clay or Shale); 2023.
- L. ASTM C270 - Standard Specification for Mortar for Unit Masonry; 2019a, with Editorial Revision.
- M. ASTM C404 - Standard Specification for Aggregates for Masonry Grout; 2018.
- N. ASTM C476 - Standard Specification for Grout for Masonry; 2023.
- O. ASTM C1634 - Standard Specification for Concrete Facing Brick and Other Concrete Masonry Facing Units; 2023a.
- P. ASTM E514/E514M - Standard Test Method for Water Penetration and Leakage Through Masonry; 2020.
- Q. BIA Technical Notes No. 7 - Water Penetration Resistance – Design and Detailing; 2017.
- R. BIA Technical Notes No. 13 - Ceramic Glazed Brick Exterior Walls; 2017.

- S. TMS 402/602 - Building Code Requirements and Specification for Masonry Structures; 2022, with Errata.

#### **1.04 SUBMITTALS**

- A. See Section 013000 - Administrative Requirements for submittal procedures.
- B. Product Data: Provide data for masonry units, fabricated wire reinforcement, mortar, and masonry accessories.
- C. Shop Drawings: Indicate pertinent dimensions, materials, anchorage, size and type of fasteners, and accessories for brickwork support system.
  - 1. Include calculations or selections from the manufacturer's prescriptive design tables that indicate compliance with the applicable building code and project conditions.
  - 2. Include the design engineer's stamp or seal on each sheet of shop drawings.
- D. Samples: Submit two samples of decorative block units to illustrate color, texture, and extremes of color range.
- E. Manufacturer's Qualification Statement.
- F. Installer's Qualification Statement.

#### **1.05 QUALITY ASSURANCE**

- A. Manufacturer Qualifications: Company specializing in manufacturing the type of products specified in this section with minimum five years of documented experience.
- B. Installer Qualifications: Company specializing in performing work of the type specified and with at least five years of documented experience.

#### **1.06 DELIVERY, STORAGE, AND HANDLING**

- A. Deliver, handle, and store masonry units by means that will prevent mechanical damage and contamination by other materials.

### **PART 2 PRODUCTS**

#### **2.01 CONCRETE MASONRY UNITS**

- A. Concrete Block: Comply with referenced standards and as follows:
  - 1. Size: Standard units with nominal face dimensions of 16 by 8 inches (400 by 200 mm) and nominal depth of 8 inches (200 mm).
  - 2. Load-Bearing Units: ASTM C90, normal weight.
    - a. Hollow block, as indicated.
    - b. Exposed Faces: Manufacturer's standard color and texture where indicated.
    - c. Manufacturers:
      - 1) Substitutions: See Section 016000 - Product Requirements.
  - 3. Nonloadbearing Units: ASTM C129.
    - a. Hollow block, as indicated.
    - b. Exposed Faces: Manufacturer's standard color and texture where indicated.
    - c. Manufacturers:
      - 1) Substitutions: See Section 016000 - Product Requirements.

#### **2.02 BRICK UNITS**

- A. Manufacturers:
  - 1. (Basis of Design) Yankee Hill Brick & Tile; [www.yankeehillbrick.com/](http://www.yankeehillbrick.com/).
  - 2. Belden Brick; [www.beldenbrick.com/#sle](http://www.beldenbrick.com/#sle).
  - 3. Meridian Brick LLC; Athens Architectural Series; [www.meridianbrick.com/#sle](http://www.meridianbrick.com/#sle).
  - 4. Substitutions: See section 016000 - Product Requirements.
- B. Facing Brick: ASTM C216, Type FBS Rough, Grade SW.
  - 1. Color and texture to match Architect's sample.
  - 2. Color: Metro Ironspot Velour
  - 3. Nominal size: As indicated on drawings.

4. Special shapes: Molded units as required by conditions indicated, unless standard units can be sawn to produce equivalent effect.

### **2.03 MORTAR AND GROUT MATERIALS**

- A. Masonry Cement: ASTM C91/C91M, Type N.
- B. Portland Cement: ASTM C150/C150M, Type I; color as required to produce approved color sample.
  1. Not more than 0.60 percent alkali.
- C. Hydrated Lime: ASTM C207, Type S.
- D. Mortar Aggregate: ASTM C144.
- E. Grout Aggregate: ASTM C404.
- F. Water: Clean and potable.

### **2.04 REINFORCEMENT AND ANCHORAGE**

- A. Manufacturers:
  1. Blok-Lok Limited: [www.blok-lok.com/#sle](http://www.blok-lok.com/#sle).
  2. Hohmann & Barnard, Inc; X-Seal Anchor: [www.h-b.com/#sle](http://www.h-b.com/#sle).
  3. WIRE-BOND [www.wirebond.com/#sle](http://www.wirebond.com/#sle).
  4. Substitutions: See Section 016000 - Product Requirements.
- B. Multiple Wythe Joint Reinforcement: ASTM A951/A951M.
  1. Type: Truss or ladder.
  2. Material: ASTM A1064/A1064M steel wire, mill galvanized to ASTM A641/A641M Class 3.
  - 3.
- C. Masonry Veneer Anchors: 2-piece anchors that permit differential movement between masonry veneer and structural backup, hot dip galvanized to ASTM A 153/A 153M, Class B.
  1. Anchor plates: Not less than 0.075 inch (1.91 mm) thick, designed for fastening to structural backup through sheathing by two fasteners; provide design with legs that penetrate sheathing and insulation to provide positive anchorage.
  2. Wire ties: Manufacturer's standard shape, 0.1875 inch (4.75 mm) thick.
  3. Vertical adjustment: Not less than 3-1/2 inches (89 mm).

### **2.05 FLASHINGS**

- A. Metal Flashing Materials:
  1. Prefabricated Metal Flashing: Smooth fabricated 12 oz/sq ft (3.66 kg/sq m) copper flashing for surface mounted conditions.
- B. Factory-Fabricated Flashing Corners and End Dams: Stainless steel.
  1. Manufacturers:
    - a. Hohmann & Barnard, Inc: [www.h-b.com/#sle](http://www.h-b.com/#sle).
    - b. Mortar Net Solutions; CompleteFlash: [www.mortarnet.com/#sle](http://www.mortarnet.com/#sle).
    - c. York Manufacturing, Inc: [www.yorkmfg.com/#sle](http://www.yorkmfg.com/#sle).
    - d. Substitutions: See Section 016000 - Product Requirements.
- C. Flashing Sealant/Adhesives: Silicone, polyurethane, or silyl-terminated polyether/polyurethane or other type required or recommended by flashing manufacturer; type capable of adhering to type of flashing used.
- D. Termination Bars: Stainless steel; compatible with membrane and adhesives.
  1. Manufacturers:
    - a. Hohmann & Barnard, Inc: [www.h-b.com/#sle](http://www.h-b.com/#sle).
    - b. Mortar Net Solutions; Termination Bars: [www.mortarnet.com/#sle](http://www.mortarnet.com/#sle).
    - c. York Manufacturing, Inc; Termination Bar: [www.yorkmfg.com/#sle](http://www.yorkmfg.com/#sle).
    - d. Substitutions: See Section 016000 - Product Requirements.
- E. Drip Edge: Stainless steel; angled drip with hemmed edge; compatible with membrane and adhesives.



- F. Lap Sealants and Tapes: As recommended by flashing manufacturer; compatible with membrane and adhesives.

## **2.06 ACCESSORIES**

- A. Preformed Control Joints: Rubber material. Provide with corner and tee accessories, fused joints.
- B. Joint Filler: Closed cell polyvinyl chloride; oversized 50 percent to joint width; self expanding; in maximum lengths available.
- C. Nailing Strips: Softwood lumber, preservative treated for moisture resistance, dovetail shape, sized to masonry joints.
- D. Cavity Vents:
  - 1. Type: Molded PVC grilles, insect resistant.
  - 2. Color(s): As selected by Architect from manufacturer's full range.
  - 3. Manufacturers:
    - a. Blok-Lok Limited: [www.blok-lok.com/#sle](http://www.blok-lok.com/#sle).
    - b. Mortar Net Solutions; CellVent: [www.mortarnet.com/#sle](http://www.mortarnet.com/#sle).
    - c. WIRE-BOND: [www.wirebond.com/#sle](http://www.wirebond.com/#sle).
    - d. Substitutions: See Section 016000 - Product Requirements.
- E. Drainage Fabric: Polyester or polypropylene mesh bonded to a water and vapor-permeable fabric.
- F. Cleaning Solution: Non-acidic, not harmful to masonry work or adjacent materials.

## **2.07 MORTAR AND GROUT MIXING**

- A. Mortar for Unit Masonry: ASTM C270, using the Proportion Specification.
  - 1. Masonry below grade and in contact with earth: Type S.
  - 2. Exterior, loadbearing masonry: Type N.
  - 3. Exterior, non-loadbearing masonry: Type N.
  - 4. Interior, loadbearing masonry: Type N.
  - 5. Interior, non-loadbearing masonry: Type O.
- B. Colored Mortar: Proportion selected pigments and other ingredients to match Architect's sample, without exceeding manufacturer's recommended pigment-to-cement ratio.
  - 1. Match mortar color of existing building. Collect sample from site.
- C. Grout: ASTM C476; consistency required to fill completely volumes indicated for grouting; fine grout for spaces with smallest horizontal dimension of 2 inches (50 mm) or less; coarse grout for spaces with smallest horizontal dimension greater than 2 inches (50 mm).
- D. Mixing: Use mechanical batch mixer and comply with referenced standards.

## **PART 3 EXECUTION**

### **3.01 EXAMINATION**

- A. Verify that field conditions are acceptable and are ready to receive masonry.
- B. Verify that related items provided under other sections are properly sized and located.
- C. Verify that built-in items are in proper location, and ready for roughing into masonry work.

### **3.02 PREPARATION**

- A. Direct and coordinate placement of metal anchors supplied for installation under other sections.
- B. Provide temporary bracing during installation of masonry work. Maintain in place until building structure provides permanent bracing.

### **3.03 COLD AND HOT WEATHER REQUIREMENTS**

- A. Comply with requirements of TMS 402/602 or applicable building code, whichever is more stringent.

### **3.04 COURSING**

- A. Establish lines, levels, and coursing indicated. Protect from displacement.
- B. Maintain masonry courses to uniform dimension. Form vertical and horizontal joints of uniform thickness.
- C. Concrete Masonry Units:
  - 1. Bond: Running.
  - 2. Coursing: One unit and one mortar joint to equal 8 inches (200 mm).
  - 3. Mortar Joints: Concave.
- D. Brick Units:
  - 1. Bond: Match existing.
  - 2. Coursing: Three units and three mortar joints to equal 8 inches (200 mm).
  - 3. Mortar Joints: Match existing.

### **3.05 PLACING AND BONDING**

- A. Lay solid masonry units in full bed of mortar, with full head joints, uniformly jointed with other work.
- B. Lay hollow masonry units with face shell bedding on head and bed joints.
- C. Buttering corners of joints or excessive furrowing of mortar joints is not permitted.
- D. Remove excess mortar and mortar smears as work progresses.
- E. Remove excess mortar with water repellent admixture promptly. Do not use acids, sandblasting or high pressure cleaning methods.
- F. Interlock intersections and external corners, except for units laid in stack bond.
- G. Do not shift or tap masonry units after mortar has achieved initial set. Where adjustment must be made, remove mortar and replace.
- H. Perform job site cutting of masonry units with proper tools to provide straight, clean, unchipped edges. Prevent broken masonry unit corners or edges.
- I. Cut mortar joints flush where wall tile is scheduled or resilient base is scheduled.
- J. Isolate masonry partitions from vertical structural framing members with a control joint as indicated.
- K. Isolate top joint of masonry partitions from horizontal structural framing members and slabs or decks with compressible joint filler.

### **3.06 MASONRY FLASHINGS**

- A. Whether or not specifically indicated, install masonry flashing to divert water to exterior at all locations where downward flow of water will be interrupted.
- B. Terminate flashing up 8 inches (203 mm) minimum on vertical surface of backing:
  - 1. Install vertical leg of flashing behind water-resistive barrier sheet over backing.
  - 2. Terminate vertical leg of flashing into bed joint in masonry or reglet in concrete.
  - 3. Anchor vertical leg of flashing into backing with a termination bar and sealant.
  - 4. Apply cap bead of sealant on top edge of self-adhered flashing.

### **3.07 CONTROL AND EXPANSION JOINTS**

- A. Do not continue horizontal joint reinforcement through control or expansion joints.
- B. Install preformed control joint device in continuous lengths. Seal butt and corner joints in accordance with manufacturer's instructions.

### **3.08 TOLERANCES**

- A. Maximum Variation from Alignment of Columns: 1/4 inch (6 mm).
- B. Maximum Variation From Unit to Adjacent Unit: 1/16 inch (1.6 mm).

- C. Maximum Variation from Plane of Wall: 1/4 inch in 10 ft (6 mm/3 m) and 1/2 inch in 20 ft (13 mm/6 m) or more.
- D. Maximum Variation from Plumb: 1/4 inch (6 mm) per story non-cumulative; 1/2 inch (13 mm) in two stories or more.
- E. Maximum Variation from Level Coursing: 1/8 inch in 3 ft (3 mm/m) and 1/4 inch in 10 ft (6 mm/3 m); 1/2 inch in 30 ft (13 mm/9 m).

**3.09 CLEANING**

- A. Remove excess mortar and mortar droppings.
- B. Replace defective mortar. Match adjacent work.
- C. Clean soiled surfaces with cleaning solution.
- D. Use non-metallic tools in cleaning operations.

**3.10 PROTECTION**

- A. Without damaging completed work, provide protective boards at exposed external corners that are subject to damage by construction activities.

**END OF SECTION**

**SECTION 055000  
METAL FABRICATIONS**

**PART 1 GENERAL**

**1.01 SECTION INCLUDES**

- A. Shop fabricated steel and aluminum items.
- B. Signage.

**1.02 RELATED REQUIREMENTS**

- A. Section 099113 - Exterior Painting: Paint finish.

**1.03 REFERENCE STANDARDS**

- A. AAMA 611 - Voluntary Specification for Anodized Architectural Aluminum; 2020.
- B. AAMA 2604 - Voluntary Specification, Performance Requirements and Test Procedures for High Performance Organic Coatings on Aluminum Extrusions and Panels (with Coil Coating Appendix); 2022.
- C. ASTM A36/A36M - Standard Specification for Carbon Structural Steel; 2019.
- D. ASTM A53/A53M - Standard Specification for Pipe, Steel, Black and Hot-Dipped, Zinc-Coated, Welded and Seamless; 2022.
- E. ASTM A283/A283M - Standard Specification for Low and Intermediate Tensile Strength Carbon Steel Plates; 2018.
- F. ASTM A501/A501M - Standard Specification for Hot-Formed Welded and Seamless Carbon Steel Structural Tubing; 2021.
- G. ASTM B209/B209M - Standard Specification for Aluminum and Aluminum-Alloy Sheet and Plate; 2021a.
- H. ASTM B221 - Standard Specification for Aluminum and Aluminum-Alloy Extruded Bars, Rods, Wire, Profiles, and Tubes; 2021.
- I. AWS A2.4 - Standard Symbols for Welding, Brazing, and Nondestructive Examination; 2020.
- J. AWS B2.1/B2.1M - Specification for Welding Procedure and Performance Qualification; 2021.
- K. AWS D1.1/D1.1M - Structural Welding Code - Steel; 2020, with Errata (2023).
- L. AWS D1.2/D1.2M - Structural Welding Code - Aluminum; 2014, with Errata (2020).
- M. SSPC-Paint 15 - Steel Joist Shop Primer/Metal Building Primer; 2004.

**1.04 SUBMITTALS**

- A. Shop Drawings: Indicate profiles, sizes, connection attachments, reinforcing, anchorage, size and type of fasteners, and accessories. Include erection drawings, elevations, and details where applicable.
  - 1. Indicate welded connections using standard AWS A2.4 welding symbols. Indicate net weld lengths.
  - 2. Design data: Submit drawings and supporting calculations, signed and sealed by a qualified professional structural engineer.
    - a. Include the following, as applicable:
      - 1) Design criteria.
      - 2) Engineering analysis depicting stresses and deflections.
      - 3) Member sizes and gauges.
      - 4) Details of connections.
      - 5) Bracing requirements.
- B. Welders' Qualification Statement: Welders' certificates in accordance with AWS B2.1/B2.1M and dated no more than 12 months before start of scheduled welding work.
- C. Fabricator's Qualification Statement: Provide documentation showing steel fabricator is accredited under IAS AC172.

## **1.05 QUALITY ASSURANCE**

- A. Design under direct supervision of a Professional Structural Engineer experienced in design of this work and licensed in the State in which the Project is located.
- B. Welder Qualifications: Welding processes and welding operators qualified in accordance with AWS D1.1/D1.1M and AWS D1.2/D1.2M and dated no more than 12 months before start of scheduled welding work.

## **PART 2 PRODUCTS**

### **2.01 MATERIALS - STEEL**

- A. Steel Sections: ASTM A36/A36M.
- B. Steel Tubing: ASTM A501/A501M hot-formed structural tubing.
- C. Plates: ASTM A283/A283M.
- D. Pipe: ASTM A53/A53M, Grade B Schedule 40, black finish.
- E. Mechanical Fasteners: Same material as or compatible with materials being fastened; type consistent with design and specified quality level.
- F. Welding Materials: AWS D1.1/D1.1M; type required for materials being welded.
- G. Shop and Touch-Up Primer: SSPC-Paint 15, complying with VOC limitations of authorities having jurisdiction.

### **2.02 MATERIALS - ALUMINUM**

- A. Extruded Aluminum: ASTM B221 (ASTM B221M), 6063 alloy, T6 temper.
- B. Sheet Aluminum: ASTM B209/B209M, 5052 alloy, H32 or H22 temper.

### **2.03 FABRICATION**

- A. Fit and shop assemble items in largest practical sections, for delivery to site.
- B. Fabricate items with joints tightly fitted and secured.
  - 1. Form exposed connections with hairline joints, flush and smooth, using concealed fasteners where possible. Locate joints where least conspicuous.
- C. Grind exposed joints flush and smooth with adjacent finish surface. Make exposed joints butt tight, flush, and hairline. Ease exposed edges to small uniform radius.
- D. Supply components required for anchorage of fabrications. Fabricate anchors and related components of same material and finish as fabrication, except where specifically noted otherwise.

### **2.04 FABRICATED ITEMS**

- A. Signage
  - 1. Manufacturers:
    - a. Basis of Design: Bo-mar Industries; 3838 S. Arlington Avenue, Indianapolis, IN 46203; bo-marind.com; 317-899-1240; ATTN: Adam Lee
    - b. Substitutions: See Section 016000 - Product Requirements
- B. Ledge Angles, Shelf Angles, Channels, and Plates Not Attached to Structural Framing: For support of signage; prime paint finish.

### **2.05 FINISHES - ALUMINUM**

- A. Exterior Aluminum Surfaces: high performance organic coating.
- B. High Performance Organic Coating System: AAMA 2604 multiple coat, thermally cured fluoropolymer system; color as indicated.
  - 1. Manufacturers:
    - a. Sherwin-Williams Company; POLANE Solar Reflective 2K Urethane Enamel: oem.sherwin-williams.com/#sle.
    - b. Substitutions: See Section 016000 - Product Requirements.

## **2.06 FABRICATION TOLERANCES**

- A. Squareness: 1/8 inch (3 mm) maximum difference in diagonal measurements.
- B. Maximum Offset Between Faces: 1/16 inch (1.5 mm).
- C. Maximum Misalignment of Adjacent Members: 1/16 inch (1.5 mm).
- D. Maximum Bow: 1/8 inch (3 mm) in 48 inches (1.2 m).
- E. Maximum Deviation From Plane: 1/16 inch (1.5 mm) in 48 inches (1.2 m).

## **PART 3 EXECUTION**

### **3.01 EXAMINATION**

- A. Verify that field conditions are acceptable and are ready to receive work.

### **3.02 PREPARATION**

- A. Clean and strip primed steel items to bare metal where site welding is required.
- B. Supply setting templates to the appropriate entities for steel items required to be cast into concrete or embedded in masonry.

### **3.03 INSTALLATION**

- A. Install items plumb and level, accurately fitted, free from distortion or defects.
- B. Provide for erection loads, and for sufficient temporary bracing to maintain true alignment until completion of erection and installation of permanent attachments.
- C. Perform field welding in accordance with AWS D1.1/D1.1M.
- D. Obtain approval prior to site cutting or making adjustments not scheduled.
- E. After erection, prime welds, abrasions, and surfaces not shop primed , except surfaces to be in contact with concrete.

### **3.04 TOLERANCES**

- A. Maximum Variation From Plumb: 1/4 inch (6 mm) per story, non-cumulative.
- B. Maximum Offset From True Alignment: 1/4 inch (6 mm).
- C. Maximum Out-of-Position: 1/4 inch (6 mm).

**END OF SECTION**

**SECTION 061000  
ROUGH CARPENTRY**

**PART 1 GENERAL**

**1.01 SECTION INCLUDES**

- A. Structural dimension lumber framing.
- B. Nonstructural dimension lumber framing.
- C. Rough opening framing for doors, windows, and roof openings.
- D. Sheathing.
- E. Subflooring.
- F. Roofing nailers.
- G. Preservative treated wood materials.
- H. Wood nailers and Curbs for roofing and items installed on roof.
- I. Miscellaneous framing and sheathing.
- J. Communications and electrical room mounting boards.
- K. Concealed wood blocking, nailers, and supports.
- L. Miscellaneous wood nailers, furring, and grounds.
- M. Wall sheathing with factory applied water-resistive and air barrier sheet.

**1.02 RELATED REQUIREMENTS**

- A. Section 033000 - Cast-in-Place Concrete: Setting anchors in concrete.
- B. Section 061753 - Shop-Fabricated Wood Trusses.
- C. Section 072500 - Weather Barriers: Air barrier over sheathing.
- D. Section 072500 - Weather Barriers: Water-resistive barrier over sheathing.
- E. Section 07 6200 - Sheet Metal Flashing and Trim: Including counterflashings, fascia and coping.
- F. Section 076200 - Sheet Metal Flashing and Trim: Sill flashings.
- G. Section 077200 - Roof Accessories: Prefabricated roof curbs.
- H. Section 092116 - Gypsum Board Assemblies: Gypsum-based sheathing.

**1.03 REFERENCE STANDARDS**

- A. ASTM A153/A153M - Standard Specification for Zinc Coating (Hot-Dip) on Iron and Steel Hardware; 2023.
- B. ASTM A653/A653M - Standard Specification for Steel Sheet, Zinc-Coated (Galvanized) or Zinc-Iron Alloy-Coated (Galvannealed) by the Hot-Dip Process; 2023.
- C. ASTM C557 - Standard Specification for Adhesives for Fastening Gypsum Wallboard to Wood Framing; 2003 (Reapproved 2017).
- D. ASTM C1177/C1177M - Standard Specification for Glass Mat Gypsum Substrate for Use as Sheathing; 2017.
- E. ASTM C1396/C1396M - Standard Specification for Gypsum Board; 2017.
- F. ASTM D3273 - Standard Test Method for Resistance to Growth of Mold on the Surface of Interior Coatings in an Environmental Chamber; 2021.
- G. ASTM D3498 - Standard Specification for Adhesives for Field-Gluing Wood Structural Panels (Plywood or Oriented Strand Board) to Wood Based Floor System Framing; 2019a.
- H. ASTM E2357 - Standard Test Method for Determining Air Leakage of Air Barrier Assemblies; 2018.

- I. ASTM E84 - Standard Test Method for Surface Burning Characteristics of Building Materials; 2023c.
- J. ASTM E136 - Standard Test Method for Assessing Combustibility of Materials Using a Vertical Tube Furnace at 750 °C; 2022.
- K. AWC (WFCM) - Wood Frame Construction Manual for One- and Two-Family Dwellings; 2018, with Errata (2019).
- L. AWPA M4 - Standard for the Care of Preservative-Treated Wood Products; 2006.
- M. AWPA U1 - Use Category System: User Specification for Treated Wood; 2023.
- N. ICC (IBC) - International Building Code; Most Recent Edition Adopted by Authority Having Jurisdiction, Including All Applicable Amendments and Supplements.
- O. ICC (IECC) - International Energy Conservation Code; Most Recent Edition Adopted by Authority Having Jurisdiction, Including All Applicable Amendments and Supplements.
- P. ICC-ES AC38 - Acceptance Criteria for Water-Resistive Barriers; 2016, with Editorial Revision (2019).
- Q. ICC-ES AC310 - Acceptance Criteria for Water-Resistive Membranes Factory-Bonded to Wood-Based Structural Sheathing, Used as Water-Resistive Barriers; 2008, with Editorial Revision (2021).
- R. PS 1 - Structural Plywood; 2023.
- S. PS 2 - Performance Standard for Wood Structural Panels; 2018.
- T. PS 20 - American Softwood Lumber Standard; 2021.
- U. SPRI RP-4 - Wind Design Standard for Ballasted Single-Ply Roofing Systems; 2002 (ANSI/SPRI RP-4).
- V. SPRI WD-1 2008 Wind Design Standard Practice for Roofing Assemblies
- W. SPRI ES-1 2011 Wind Design Standard for Edge Systems Used with Low-Slope Roofing Systems
- X. SPIB (GR) - Standard Grading Rules; 2021.
- Y. WWP A G-5 - Western Lumber Grading Rules; 2021.

#### **1.04 SUBMITTALS**

- A. See Section 013000 - Administrative Requirements for submittal procedures.
- B. Product Data: Provide technical data on insulated sheathing, wood preservative materials, and application instructions.
- C. Manufacturer's Certificate: Certify that wood products supplied for rough carpentry meet or exceed specified requirements.

#### **1.05 DELIVERY, STORAGE, AND HANDLING**

- A. General: Cover wood products to protect against moisture. Support stacked products to prevent deformation and to allow air circulation.

### **PART 2 PRODUCTS**

#### **2.01 GENERAL REQUIREMENTS**

- A. Dimension Lumber: Comply with PS 20 and requirements of specified grading agencies.
  - 1. If no species is specified, provide species graded by the agency specified; if no grading agency is specified, provide lumber graded by grading agency meeting the specified requirements.
  - 2. Grading Agency: Grading agency whose rules are approved by the Board of Review, American Lumber Standard Committee at [www.alsc.org](http://www.alsc.org), and who provides grading service for the species and grade specified; provide lumber stamped with grade mark unless otherwise indicated.



- B. Provide sustainably harvested wood; see Section 016000 - Product Requirements for requirements.
- C. Provide wood harvested within a 500 mile (805 km) radius of the project site.
- D. Lumber fabricated from recovered timber is permitted in lieu of sustainably harvested lumber, unless otherwise noted, provided it meets the specified requirements for new lumber and is free of contamination; identify source.

## 2.02 DIMENSION LUMBER FOR CONCEALED APPLICATIONS

- A. Grading Agency: Southern Pine Inspection Bureau, Inc; SPIB (GR).
- B. Sizes: Nominal sizes as indicated on drawings, S4S.
- C. Moisture Content: S-dry or MC19.
- D. Stud Framing (2 by 2 through 2 by 8 (\_\_\_\_) ):
  - 1. Species: Allowed under referenced grading rules.
  - 2. Grade: No. 2.
- E. Miscellaneous Framing, Blocking, Nailers, Grounds, and Furring:
  - 1. Lumber: S4S, No. 2 or Standard Grade.

## 2.03 STRUCTURAL PANELS

- A. Subfloor/Underlayment Combination: Oriented strand board wood structural panel; PS 2, rated Single Floor.
  - 1. Span Rating: 48.
  - 2. Edges: Tongue and groove.
  - 3. Exposure Time: Sheathing will not delaminate or require sanding due to moisture absorption from exposure to weather for up to 200 days.
  - 4. Provide fastening guide on top panel surface with separate markings indicating fastener spacing for 16 inches (406 mm), 19.2 inches (488 mm) and 24 inches (610 mm) on center, respectively.
- B. Subflooring: Structural cementitious subfloor panels.
  - 1. Size: 48 inches (1220 mm) wide nominal, by 96 inches (2440 mm) long, nominal.
  - 2. Thickness: 3/4 inch (19 mm), nominal.
  - 3. Edges: Square along width; tongue and groove along length.
  - 4. Span: 24 inches (610 mm), maximum.
  - 5. Fire Resistance: Noncombustible, when tested in accordance with ASTM E136.
  - 6. Surface Burning Characteristics: Flame spread index of 0; smoke-developed Index of 0; when tested in accordance with ASTM E84.
  - 7. Mold Resistance: Rating of 10, when tested in accordance with ASTM D3273.
- C. Wall Sheathing: Glass mat faced gypsum, ASTM C1177/C1177M, 5/8 inch Type X fire resistant (16 mm Type X fire resistant).
- D. Wall Sheathing: Oriented strand board structural wood panel with factory laminated water-resistive and air barrier layer.
  - 1. Sheathing Panel: PS 2, Exposure 1.
    - a. Size: 4 feet (1219 mm) wide by 8 feet (2438 mm) long.
    - b. Grade: Structural 1 Sheathing.
    - c. Performance Category: 7/16 PERF CAT.
    - d. Span Rating: 24/16.
    - e. Edge Profile: Square edge.
  - 2. Integral Water-Resistive and Air Barrier: Sheet material qualifying as a Grade D water resistive barrier; complying with ICC-ES AC310.
  - 3. Maximum Allowable Air Leakage of Assembly, complying with ASTM E2357:
    - a. Infiltration: 0.0072 cfm per square foot (0.037 L/s per sq m), maximum, at a pressure differential of 1.57 pounds per square foot (75 Pa).
    - b. Exfiltration: 0.0023 cfm per square foot (0.012 L/s per sq m), maximum, at a pressure differential of 1.57 pounds per square foot (75 Pa).

4. Provide fastening guide on top panel surface with separate markings indicating fastener spacing for 16 inches (406 mm) and 24 inches (610 mm) on center, respectively.
  5. Seam Tape: Manufacturer's standard pressure-sensitive, self-adhering, cold-applied, seam tape.
- E. Concealed Plywood for Roofing Applications:
1. Plywood Concealed From View But Located Within Exterior Enclosure: PS 1, C-C Plugged or better, Exterior grade.
    - a. Thickness indicated but not less than 1/2 inch nominal.

## 2.04 ACCESSORIES

- A. Fasteners and Anchors:
1. Metal and Finish: Hot-dipped galvanized steel complying with ASTM A153/A153M for high humidity and preservative-treated wood locations, unfinished steel elsewhere.
  2. Drywall Screws: Bugle head, hardened steel, power driven type, length three times thickness of sheathing.
- B. Sill Gasket on Top of Foundation Wall: 1/4 inch (6 mm) thick, plate width, closed cell plastic foam from continuous rolls.
- C. Sill Flashing: As specified in Section 076200.
- D. Subfloor Adhesives: Waterproof, air cure type, cartridge dispensed; adhesives designed for subfloor applications and complying with either ASTM C557 or ASTM D3498.
- E. Water-Resistive Barrier: As specified in Section 072500.

## 2.05 FACTORY WOOD TREATMENT

- A. Treated Lumber and Plywood: Comply with requirements of AWPA U1 - Use Category System for wood treatments determined by use categories, expected service conditions, and specific applications.
1. Preservative-Treated Wood: Provide lumber and plywood marked or stamped by an ALSC-accredited testing agency, certifying level and type of treatment in accordance with AWPA standards.
- B. Preservative Treatment:
1. Manufacturers:
    - a. Lonza Group; \_\_\_\_: [www.wolmanizedwood.com/#sle](http://www.wolmanizedwood.com/#sle).
    - b. Koppers Performance Chemicals, Inc; \_\_\_\_: [www.koppersperformancechemicals.com/#sle](http://www.koppersperformancechemicals.com/#sle).
    - c. Viance, LLC; Preserve ACQ: [www.treatedwood.com/#sle](http://www.treatedwood.com/#sle).
    - d. Substitutions: See Section 016000 - Product Requirements.
- C. Preservative Pressure Treatment of Lumber Above Grade: AWPA U1, Use Category UC3B, Commodity Specification A using waterborne preservative.
1. Kiln dry lumber after treatment to maximum moisture content of 19 percent.
    - a. Treat lumber exposed to weather.
  2. Treat lumber in contact with roofing, flashing, or waterproofing.
  3. Treat lumber in contact with masonry or concrete.
  4. Treat lumber less than 18 inches (450 mm) above grade.
    - a. Treat lumber in other locations as indicated.

## PART 3 EXECUTION

### 3.01 PREPARATION

- A. Where wood framing bears on cementitious foundations, install full width sill flashing continuous over top of foundation, lap ends of flashing minimum of 4 inches (100 mm) and seal.
- B. Install sill gasket under sill plate of framed walls bearing on foundations; puncture gasket cleanly to fit tightly around protruding anchor bolts.
- C. Coordinate installation of rough carpentry members specified in other sections.

### **3.02 INSTALLATION - GENERAL**

- A. Select material sizes to minimize waste.
- B. Reuse scrap to the greatest extent possible; clearly separate scrap for use on site as accessory components, including: shims, bracing, and blocking.
- C. Where treated wood is used on interior, provide temporary ventilation during and immediately after installation sufficient to remove indoor air contaminants.

### **3.03 FRAMING INSTALLATION**

- A. Set structural members level, plumb, and true to line. Discard pieces with defects that would lower required strength or result in unacceptable appearance of exposed members.
- B. Make provisions for temporary construction loads, and provide temporary bracing sufficient to maintain structure in true alignment and safe condition until completion of erection and installation of permanent bracing.
- C. Install structural members full length without splices unless otherwise specifically detailed.
- D. Comply with member sizes, spacing, and configurations indicated, and fastener size and spacing indicated, but not less than required by applicable codes and AWC (WFCM) Wood Frame Construction Manual.
- E. Construct double joist headers at floor and ceiling openings and under wall stud partitions that are parallel to floor joists; use metal joist hangers unless otherwise detailed.
- F. Frame wall openings with two or more studs at each jamb; support headers on cripple studs.

### **3.04 BLOCKING, NAILERS, AND SUPPORTS**

- A. Provide framing and blocking members as indicated or as required to support finishes, fixtures, specialty items, and trim.
- B. In metal stud walls, provide continuous blocking around door and window openings for anchorage of frames, securely attached to stud framing.
- C. In walls, provide blocking attached to studs as backing and support for wall-mounted items, unless item can be securely fastened to two or more studs or other method of support is explicitly indicated.
- D. Where ceiling-mounting is indicated, provide blocking and supplementary supports above ceiling, unless other method of support is explicitly indicated.
- E. Provide the following specific nonstructural framing and blocking:
  - 1. Cabinets and shelf supports.
  - 2. Wall brackets.
  - 3. Grab bars.
  - 4. Towel and bath accessories.
  - 5. Wall-mounted door stops.
  - 6. Chalkboards and marker boards.

### **3.05 ROOF-RELATED CARPENTRY**

- A. Coordinate installation of roofing carpentry with deck construction, framing of roof openings, and roofing assembly installation.
- B. Cut and fit miscellaneous carpentry accurately and securely fasten. Install members plumb and true to line and level.
- C. Install perimeter wood nailers true to line and level, with the outside edge of wood nailer aligned flush with outermost wall face. Comply with recommendations of National Roofing Contractors Association (NRCA) "Roofing and Waterproofing Manual", third edition.
- D. Install perimeter wood nailers as recommended "Low Slope membrane edge securement, except gutter, shall be designated, tested and installed for Building Code wind load requirements, and tested for resistance in accordance with ANSI/SPRI ES-1.

- E. Install wood grounds, nailers, blocking, and sleepers where shown and where required for screeding or attachment of other work as follows:
- F. Wood nailers installed at building corners (with corners being defined as the distance from the building corner that is 10% of the minimum building width or 40% of the building height at the eaves, whichever is smaller, but in case less than 3 feet) are to be installed and secured so that basic attachment is sufficient enough to resist a minimum of 200 pounds per foot force.
- G. Wood nailers installed at perimeter sections of the roof edge located between the corners, are to be installed and secured so that the basic attachment is sufficient enough to resist a minimum of 100 pounds per foot force.
- H. Blocking at all edge conditions should be a minimum thickness of 1.5 inches and be sufficient width to extend at least 1/2 inch minimum beyond the nailing flange of the roof edge flashing.
- I. Install fasteners without splitting wood blocking.
- J. Fasten wood blocking to allow for expansion at joints, unless otherwise noted.
- K. Wood blocking secured to either masonry, steel or additional wood members as follows:
  1. Masonry: when the bottom nailer is to be installed in direct contact with masonry, the nailer is to be secured with a corrosion resistant anchor bolt, countersunk into nailer and attached to nailer with a nut and washer. Anchor bolts should be a minimum 1/2 inch in diameter and spaced 4 feet c/c max. apart. If nailer is larger than 6 inches, then anchor bolts should be staggered to avoid splitting the wood. Anchors are to be bent 90 degrees at the base or have heads designed to prevent rotation and slipping out. When securing nailers to hollow block masonry at roof line, fill cores or voids in the top row with full density concrete.
  2. Steel deck: when bottom nailer is anchored directly to steel, a steel angle needs to be installed. Nailer is anchored to steel with corrosion resistant anchor bolts, minimum 1/2 inch in diameter and spaced 4 foot center to center maximum. When the deck is a minimum 22 ga steel, the angle should be secured to the deck with fasteners having a minimum 360 pound pull out rating. Fasteners for steel angle are to be installed on maximum 12 inch centers with a minimum 5/8 inch diameter washer under the screw heads.
  3. Additional Wood Blocking: when additional wood blocking is stacked onto new or existing blocking, the securement of the blocking that is being anchored too should be verified for proper securement. Additional stacked wood blocking onto existing blocking properly secured, should be fastened with corrosion resistant screws having a pull-out resistance of at least 360 pounds per fastener. Screws are to be staggered and spaced a maximum 12-inches center to center. Screws in corners are to be staggered and spaced 6-inches maximum center to center.
  4. Concrete and Gypsum Decks: Wood blocking is not to be fastened directly to concrete or gypsum decks. Wood blocking needs to be installed directly to wall structure.

### **3.06 INSTALLATION OF STRUCTURAL PANELS**

- A. Subflooring/Underlayment Combination: Glue and nail to framing; staples are not permitted.
- B. Wall Sheathing: Secure with long dimension perpendicular to wall studs, with ends over firm bearing and staggered, using nails, screws, or staples.
  1. Place water-resistive barrier horizontally over wall sheathing, weather lapping edges and ends.

### **3.07 CLEANING**

- A. Waste Disposal: See Section 017419 - Construction Waste Management and Disposal.
  1. Comply with applicable regulations.
  2. Do not burn scrap on project site.
  3. Do not burn scraps that have been pressure treated.
  4. Do not send materials treated with pentachlorophenol, CCA, or ACA to co-generation facilities or "waste-to-energy" facilities.
- B. Do not leave wood, shavings, sawdust, etc. on the ground or buried in fill.

C. Prevent sawdust and wood shavings from entering the storm drainage system.

**END OF SECTION**

**SECTION 061600.16  
SHEATHING**

**PART 1 GENERAL**

**1.01 RELATED DOCUMENTS**

- A. Drawings and general provisions of the Contract, including General and Supplementary Conditions and Division 01 Specification Sections, apply to this Section.

**1.02 SUMMARY**

- A. Section Includes:
  - 1. Combination wall sheathing, water resistive barrier and air barrier.
  - 2. Self-adhering flexible flashing.
  - 3. Liquid-applied flashing membrane.
- B. Related Requirements:
  - 1. Section 061000 "Rough Carpentry" for plywood backing panels.

**1.03 ACTION SUBMITTALS**

- A. Product Data: For each type of process and factory-fabricated product. Indicate component materials and dimensions and include construction and application details.
  - 1. For panels with integral water resistive barrier, include data on air/-moisture-infiltration protection based on testing according to referencing standards.

**1.04 QUALITY ASSURANCE**

- A. Manufacturer Qualifications: Capable of demonstrating that all wood procurement operations are conducted in accordance with procedures and policies of the Sustainable Forestry Initiative (SFI) Program.
- B. Code Compliance: Comply with requirements of the following:
  - 1. International Code Council (ICC), ICC-ESR1473.
  - 2. International Code Council (ICC), ICC-ESR1474.
  - 3. International Code Council (ICC), ICC-ESR2227.

**1.05 DELIVERY, STORAGE, AND HANDLING**

- A. Outdoor Storage. Comply with manufacturer's recommendations and as follows:
  - 1. Set panel bundles on supports to keep off ground.
  - 2. Cover panels loosely with waterproof protective material.
  - 3. Anchor covers on top of stack, but keep away from sides and bottom to assure adequate air circulation.
  - 4. When high moisture conditions exist, cut banding on panel stack to prevent edge damage.

**1.06 WARRANTY**

- A. Special Warranty: Manufacturer's standard form in which manufacturer agrees to repair or replace components of sheathing system that fail due to manufacturing defects within specified warranty period.
  - 1. Construction Period Warranty: Manufacturer shall warrant the panels and tape for weather exposure for a period of 180 days from installation.
  - 2. System Warranty Period: 30 years from date of Substantial Completion.

**PART 2 PRODUCTS**

**2.01 PERFORMANCE REQUIREMENTS**

- A. Fire-Resistance Ratings: As tested according to ASTM E 119; testing by a qualified testing agency. Identify products with appropriate markings of applicable testing agency.
  - 1. Fire-Resistance Ratings: Indicated by design designations from UL's "Fire Resistance Directory" or from the listings of another qualified testing agency.

**2.02 WOOD PANEL PRODUCTS**

- A. Oriented Strand Board: DOC PS 2-10.

- B. Thickness: As needed to comply with requirements specified, but not less than thickness indicated. Thickness shall satisfy minimum and maximum requirements for referenced performance category.
- C. Factory mark panels to indicate compliance with applicable standard.

### **2.03 COMBINATION WALL SHEATHING, AIR AND WATER-RESISTIVE BARRIER**

- A. Oriented-Strand-Board Wall Sheathing: With integral water-resistive barrier, Exposure 1 sheathing.
  - 1. Basis-of-Design Product: Subject to compliance with requirements, provide Huber Engineered Woods LLC; ZIP System® Wall Sheathing or a comparable product by one of the following:
    - a.
  - 2. Span Rating, Panel Grade and Performance Category: Not less than 24/16; Structural 1, 7/16 Performance Category.
  - 3. Edge Profile: Square edge.
  - 4. Provide fastening guide on top panel surface with pre-spaced fastening symbols for 16-inches (406 mm) and 24-inches (610 mm) on centers spacing.
  - 5. Performance Standard: DOC PS2-10 and ICC-ES ESR-1474.
  - 6. Factory laminated integral water-resistive barrier facer.
  - 7. Perm Rating of Integral Water-Resistive Barrier: 12-16 perms.
  - 8. Assembly maximum air leakage of 0.0072 cfm/sq. ft. (0.037 L/s x sq. m) infiltration and 0.0023 cfm/ sq. ft. (0.012 L/s x sq. m) exfiltration at a pressure differential of 1.57 (psf 75 Pa).
  - 9. Exposure Time: Designed to resist weather exposure for 180 days.

### **2.04 FASTENERS**

- A. General: Provide fasteners of size and type that comply with requirements specified in this article by the authority having jurisdiction, International Building Code, International Residential Code, Wood Frame Construction manual, and National Design Specification.

### **2.05 MISCELLANEOUS MATERIALS**

- A. Self-Adhering Seam and Flashing Tape: Pressure-sensitive, self-adhering, cold-applied, proprietary seam tape consisting of polyolefin film with acrylic adhesive.
  - 1. Basis-of-Design Product: Subject to compliance with requirements provide Huber Engineered Woods; ZIP System® Seam and Flashing Tape.
  - 2. Thickness: 0.012 inch (0.3 mm).
  - 3. Width: [3.75 inch (95.3 mm)] [6 inch (152.4 mm)].
  - 4. Code Compliance: Comply with requirements of authorities having jurisdiction and ICC Evaluation Service, Inc. "AC148 - Acceptance Criteria for Flexible Flashing Materials."
  - 5. International Code Council (ICC), ICC-ES ESR2227.
  - 6. American Architectural Manufacturer's Association; AAMA 711.
- B. Liquid-Applied Flashing Membrane: Gun-grade, cold-applied, silyl-terminated polyether (STPE) liquid flashing membrane compatible with sheathing/weather barrier and self-adhering seam and flashing tape, and tested as part of an assembly meeting performance requirements. Follow manufacturer's recommendation for integration with self-adhering seam and flashing tape.
  - 1. Basis-of-Design Product: Subject to compliance with requirements, provide Huber Engineered Woods; ZIP System® Liquid Flash or a comparable product.
  - 2. Hardness, Shore A, ASTM C 661: 40 to 45.
  - 3. Total Solids: 99 percent.
  - 4. Tensile Strength, ASTM D 412: 75 psi (517 kPa).
- C. Self-Adhering Flexible Flashing Tape: Pressure-sensitive, self-adhering, cold-applied, flexible flashing tape consisting of a flexible acrylic foam backing with acrylic adhesive.
  - 1. Basis-of-Design Product: Subject to compliance with requirements provide Huber Engineered Woods; ZIP System® Stretch Tape.

2. Thickness: 0.042 inch (1.067 mm).
3. Width: [6 inch (150 mm)] [10 inch (254 mm)].
4. Code Compliance: Comply with requirements of authorities having jurisdiction and ICC Evaluation Service, Inc. "AC148 - Acceptance Criteria for Flexible Flashing Materials."
5. International Association of Plumbing and Mechanical Officials (IAPMO), IAPMO ER365.
6. American Architectural Manufacturer's Association; AAMA 711.

## **PART 3 EXECUTION**

### **3.01 INSTALLATION, GENERAL**

- A. Do not use materials with defects that impair quality of sheathing or pieces that are too small to use with minimum number of joints or optimum joint arrangement.
- B. Cut panels at penetrations, edges, and other obstructions of work; fit tightly against abutting construction unless otherwise indicated.
- C. Securely attach to substrate by fastening as indicated, complying with the following:
  1. Chapter 23 in the ICC's International Building Code.
  2. Table R602.3(1), "Fastener Schedule for Structural Members," and Table R602.3(2), "Alternate Attachments," in the ICC's International Residential Code for One- and Two-Family Dwellings.
  3. ICC-ES evaluation report for fastener.
- D. Use common wire nails unless otherwise indicated. Select fasteners of size that will not fully penetrate members where opposite side will be exposed to view or will receive finish materials. Make tight connections. Install fasteners without splitting wood.
- E. Coordinate [wall] [parapet] [and] [roof] sheathing installation with flashing and joint-sealant installation so these materials are installed in sequence and manner that prevent exterior moisture from passing through completed assembly.
- F. Do not bridge building expansion joints; cut and space edges of panels to match spacing of structural support elements.
- G. Only mechanically attached and drainable EIFS and exterior insulation should be used with ZIP System wall sheathing.

### **3.02 WOOD STRUCTURAL PANEL INSTALLATION**

- A. General: Comply with applicable recommendations in APA Form No. E30, "Engineered Wood Construction Guide," for types of structural-use panels and applications indicated.
- B. Fastening Methods: Fasten panels as indicated below:
  1. Wall and Roof Sheathing:
    - a. Nail or staple to wood framing.
    - b. Screw to cold-formed metal framing.
    - c. Space panels 1/8 inch (3 mm) apart at edges and ends.
    - d. Install fasteners 3/8 inch (9.5 mm) to 1/2 inch (12.7 mm) from panel edges.
    - e. Space fasteners in compliance with requirements of authority having jurisdiction.

### **3.03 SHEATHING JOINT TREATMENT**

- A. Seal sheathing joints according to sheathing manufacturer's written instructions.
  1. Apply seam tape to joints between sheathing panels.
  2. Utilize tape gun or hard rubber roller provided by manufacturer to ensure tape is completely adhered to substrates.
  3. When using liquid-applied flashing to seal sheathing joints follow manufacturer's recommendations for sealing panel seams.

### **3.04 FLEXIBLE OR LIQUID-APPLIED FLASHING INSTALLATION**

- A. Apply tape flexible flashing or membrane where indicated to comply with manufacturer's written instructions.
  1. After flexible flashing tape has been applied, roll surfaces with a hard rubber to ensure that flashing is completely adhered to substrates.



2. Width for flexible flashing: 6 inch (154.4 mm).
  3. Apply liquid-applied flashing membrane at penetrations, gaps, and cracks to form continuous weathertight surface. Apply liquid membrane according to manufacturer's written instructions. Follow manufacturer's recommendation for integration with seam and flashing tape.
- B. Apply liquid applied flashing membrane where indicated to comply with manufacturer's written instructions.
1. After liquid applied flashing membrane has been applied, tool wet product with a plastic spreader, putty knife, or similar tool to ensure that flashing is opaque and substrate is no longer visible.
  2. Minimum Thickness for Liquid Flashing: 12 mils (0.3 mm).
  3. Apply liquid flashing membrane according to manufacturer's written instructions. Follow manufacturer's recommendations for integration with seam and flashing tape or flexible flashing tape.
- C. Apply flexible flashing tape where indicated to comply with manufacturer's written instructions.
1. After flexible flashing tape has been applied, roll surfaces with a hard rubber to ensure that flashing is completely adhered to substrates.
  2. Width of flexible flashing: 6 inches (154.4 mm) or 10 inches (254 mm).

**END OF SECTION**

**SECTION 061753  
SHOP-FABRICATED WOOD TRUSSES**

**PART 1 GENERAL**

**1.01 SECTION INCLUDES**

- A. Shop fabricated wood trusses for roof and floor framing.
- B. Bridging, bracing, and anchorage.
- C. Fire retardant treatment of wood.

**1.02 RELATED REQUIREMENTS**

- A. Section 061000 - Rough Carpentry: Installation requirements for miscellaneous framing.
- B. Section 061000 - Rough Carpentry: Material requirements for blocking, bridging, plates, and miscellaneous framing.
- C. Structural Notes in Construction Drawing Set are to take precedence over requirements within this Section.

**1.03 REFERENCE STANDARDS**

- A. ANSI/TPI 1 - National Design Standard for Metal-Plate-Connected Wood Truss Construction; 2014.
- B. TPI BCSI 1 - Building Component Safety Information Booklet: The Guide to Good Practice for Handling, Installing & Bracing of Metal Plate Connected Wood Trusses; 2018.
- C. TPI DSB-89 - Recommended Design Specification for Temporary Bracing of Metal Plate Connected Wood Trusses; 1989.

**1.04 SUBMITTALS**

- A. See Section 013000 - Administrative Requirements, for submittal procedures.
- B. Product Data: Manufacturer's data sheets on plate connectors, bearing plates, and metal bracing components.
- C. Shop Drawings: Show truss configurations, sizes, spacing, size and type of plate connectors, cambers, framed openings, bearing and anchor details, and bridging and bracing.
  - 1. Include identification of engineering software used for design.
  - 2. Provide shop drawings stamped or sealed by design engineer.

**1.05 QUALITY ASSURANCE**

- A. Designer Qualifications: Perform design by or under direct supervision of a Professional Structural Engineer experienced in design of this Work and licensed in Indiana.
- B. Truss Fabricator will be responsible for providing signed and sealed truss drawings for State of Indiana component submittal.
- C. Fabricator Qualifications: Company specializing in manufacturing the products specified in this section with minimum five years of documented experience.

**1.06 DELIVERY, STORAGE, AND HANDLING**

- A. Handle and erect trusses in accordance with TPI BCSI 1.
- B. Store trusses in vertical position resting on bearing ends.

**PART 2 PRODUCTS**

**2.01 MANUFACTURERS**

- A. Truss Plate Connectors:
  - 1. Alpine, an ITW Company: [www.alpineitw.com/#sle](http://www.alpineitw.com/#sle).
  - 2. MiTek Industries, Inc: [www.mii.com/#sle](http://www.mii.com/#sle).
  - 3. Substitutions: See Section 016000 - Product Requirements.
- B. Truss Fabricators:
  - 1. Blg C Lumber; Wood Trusses: [www.bigclumber.com/](http://www.bigclumber.com/)

2. Carter Lumber; Engineered Wood Trusses: [www.carterlumber.com/](http://www.carterlumber.com/)
3. Northern Indiana Truss Company; Wood Truss Manufacturing: [www.northernintruss.com/](http://www.northernintruss.com/)
4. Substitutions: See Section 016000 - Product Requirements.

## **2.02 TRUSSES**

- A. Wood Trusses: Designed and fabricated in accordance with ANSI/TPI 1 and TPI DSB-89 to achieve structural requirements indicated.

## **2.03 MATERIALS**

- A. Lumber:
  1. Moisture Content: Between 7 and 9 percent.
  2. Lumber fabricated from old growth timber is not permitted.
- B. Truss Bridging: Type, size and spacing recommended by truss manufacturer.

## **2.04 ACCESSORIES**

- A. Wood Blocking, Bridging, Plates, and Miscellaneous Framing: Softwood lumber, any species, construction grade, 19 percent maximum and 7 percent minimum moisture content.
- B. Fasteners: Electrogalvanized steel, type to suit application.
- C. Bearing Plates: Electrogalvanized steel.

## **PART 3 EXECUTION**

### **3.01 EXAMINATION**

- A. Verify that field measurements are as indicated.
- B. Verify that supports and openings are ready to receive trusses.

### **3.02 PREPARATION**

- A. Coordinate placement of bearing items.

### **3.03 ERECTION**

- A. Install trusses in accordance with manufacturer's instructions and TPI DSB-89 and TPI BCSI 1; maintain a copy of each TPI document on site until installation is complete.
- B. Set members level and plumb, in correct position.
- C. Install permanent bridging and bracing.

### **3.04 TOLERANCES**

- A. Framing Members: 1/2 inch (12 mm) maximum, from true position.

**END OF SECTION**

**SECTION 062000  
FINISH CARPENTRY**

**PART 1 GENERAL**

**1.01 SECTION INCLUDES**

- A. Finish carpentry items.
- B. Wood door frames, glazed frames.

**1.02 RELATED REQUIREMENTS**

**1.03 REFERENCE STANDARDS**

- A. AWI/AWMAC/WI (AWS) - Architectural Woodwork Standards, 2nd Edition; 2014, with Errata (2016).
- B. AWMAC/WI (NAAWS) - North American Architectural Woodwork Standards; 2021, with Errata.
- C. GSA CID A-A-1936 - Adhesives, Contact, Neoprene Rubber; 1996a (Validated 2013).
- D. PS 20 - American Softwood Lumber Standard; 2021.

**1.04 SUBMITTALS**

- A. See Section 013000 - Administrative Requirements for submittal procedures.
- B. Product Data:
  - 1. Provide manufacturer's product data, storage and handling instructions for factory-fabricated units.
- C. Shop Drawings: Indicate materials, component profiles, fastening methods, jointing details, and accessories.
  - 1. Provide information as required by AWI/AWMAC/WI (AWS) or AWMAC/WI (NAAWS).
- D. Samples: Submit two samples of finish plywood, 6x6 inch (\_\_\_\_x\_\_\_\_ mm) in size illustrating wood grain and specified finish.

**1.05 QUALITY ASSURANCE**

- A. Fabricator Qualifications: Company specializing in fabricating the products specified in this section with minimum five years of documented experience.

**1.06 DELIVERY, STORAGE, AND HANDLING**

- A. Deliver factory-fabricated units to project site in original packages, containers or bundles bearing brand name and identification.
- B. Store finish carpentry items under cover, elevated above grade, and in a dry, well-ventilated area not exposed to heat or sunlight.
- C. Protect from moisture damage.
- D. Handle materials and products to prevent damage to edges, ends, or surfaces.

**PART 2 PRODUCTS**

**2.01 FINISH CARPENTRY ITEMS**

- A. Quality Standard: Custom Grade, in accordance with AWI/AWMAC/WI (AWS) or AWMAC/WI (NAAWS), unless noted otherwise.
- B. Interior Woodwork Items:
  - 1. Moldings, Bases, Casings, and Miscellaneous Trim: Clear white pine; prepare for paint finish.
  - 2. Window Sills: Clear fir; prepare for transparent finish.
  - 3. Loose Shelving: Birch plywood; prepare for paint finish.

**2.02 SUSTAINABILITY CHARACTERISTICS**

- A. Provide sustainably harvested wood, certified or labeled; see Section 016000.
- B. Provide wood harvested within specified radius of project site; see Section 016000.

### **2.03 FASTENINGS**

- A. Adhesive for Purposes Other Than Laminate Installation: Suitable for the purpose; not containing formaldehyde or other volatile organic compounds.

### **2.04 ACCESSORIES**

- A. Adhesive: Type recommended by fabricator to suit application.

### **2.05 FABRICATION**

- A. Shop assemble work for delivery to site, permitting passage through building openings.
- B. When necessary to cut and fit on site, provide materials with ample allowance for cutting. Provide trim for scribing and site cutting.

## **PART 3 EXECUTION**

### **3.01 EXAMINATION**

- A. Verify adequacy of backing and support framing.

### **3.02 INSTALLATION**

- A. Install custom fabrications in accordance with AWI/AWMAC/WI (AWS) or AWMAC/WI (NAAWS) requirements for grade indicated.
- B. Set and secure materials and components in place, plumb and level.
- C. Carefully scribe work abutting other components, with maximum gaps of 1/32 inch (0.79 mm). Do not use additional overlay trim to conceal larger gaps.

### **3.03 TOLERANCES**

- A. Maximum Variation from True Position: 1/16 inch (1.6 mm).
- B. Maximum Offset from True Alignment with Abutting Materials: 1/32 inch (0.79 mm).

**END OF SECTION**

**SECTION 066600  
CELLULAR PVC FABRICATIONS**

**PART 1 GENERAL**

**1.01 SECTION INCLUDES**

- A. Cellular PVC fabrications including the following:
  - 1. Trim

**1.02 RELATED SECTIONS**

- A. Section 06 10 00 - Rough Carpentry.

**1.03 REFERENCES**

- A. ASTM International (ASTM): ASTM E84 - Standard Test Method for Surface Burning Characteristics of Building Materials.

**1.04 SUBMITTALS**

- A. Submit under provisions of Section 01 30 00 - Administrative Requirements.
- B. Product Data: Manufacturer's data sheets on each product to be used, including:
  - 1. Preparation instructions and recommendations.
  - 2. Storage and handling requirements and recommendations.
  - 3. Installation methods.
- C. Verification Samples: For each finish product specified, two samples, minimum size 6 inches (150 mm) square representing actual product, color, and patterns.

**1.05 QUALITY ASSURANCE**

- A. Installer Qualifications: Minimum 2 years experience installing similar products.

**1.06 DELIVERY, STORAGE, AND HANDLING**

- A. Deliver and store products in manufacturer's unopened packaging bearing the brand name and manufacturer's identification until ready for installation.
- B. Comply with manufacturer's recommendations. Handle materials to avoid damage.

**1.07 PROJECT CONDITIONS**

- A. Maintain environmental conditions (temperature, humidity, and ventilation) within limits recommended by manufacturer for optimum results. Do not install products under environmental conditions outside manufacturer's recommended limits.

**1.08 WARRANTY**

- A. Provide manufacturer's standard limited warranty for products, stating that components will be free from defects in material that occur as a direct result of the manufacturing process, occur under normal use and service, occur during the warranty period and result in blistering, peeling, flaking, cracking, splitting, cupping, rotting or structural defects from termites or fungal decay.
  - 1. Trim Warranty Period: 25 years.

**PART 1 PRODUCTS**

**2.01 MANUFACTURERS**

- A. AZEK Building Products, Inc., 894 Prairie Ave.; Wilmington, OH 45177; ASD Toll Free Tel: 877-ASK-AZEK; Email: request info; Web: <https://www.azek.com>; <https://timbertech.com>
- B. CertainTeed Corporation, 20 Moores Road, Malvern, Pennsylvania 19355. Tel: (800) 233-8990; Email: [salesupportgroup@certainteed.com](mailto:salesupportgroup@certainteed.com); Web: [www.certainteed.com](http://www.certainteed.com).
- C. Versatex, 400 Steel Street; Aliquippa, PA 15001; Tel: 724-857-1171; Email: [sales@verstex.com](mailto:sales@verstex.com); Web: [www.versatex.com](http://www.versatex.com)
- D. Requests for substitutions will be considered in accordance with provisions of Section 01 60 00.

**2.02 TRIM**

- A. Fire Performance Characteristics: Provide products complying with the following:

1. Flame Spread Index: Less than 25, ASTM E 84.
- B. PVC Trim: Material shall have the following characteristics:
  1. Material: Solid Cellular PVC.
  2. Finish: Smooth
  3. Color: White
  4. Trim Size, 5/4 Thickness:
    - a. 5/4 x 4 x 12 feet nominal, 1 inches x 3-1/2 inches by 12 feet actual dimension.
    - b. 5/4 x 4 x 18 feet nominal, 1 inches x 3-1/2 inches by 18 feet actual dimension.
    - c. 5/4 x 6 x 12 feet nominal, 1 inches x 5-1/2 inches by 12 feet actual dimension.
    - d. 5/4 x 6 x 18 feet nominal, 1 inches x 5-1/2 inches by 18 feet actual dimension.
    - e. 5/4 x 8 x 12 feet nominal, 1 inches x 7-1/4 inches by 12 feet actual dimension.
    - f. 5/4 x 8 x 18 feet nominal, 1 inches x 7-1/4 inches by 18 feet actual dimension.
    - g. 5/4 x 10 x 12 feet nominal, 1 inches x 9-1/4 inches by 12 feet actual dimension.
    - h. 5/4 x 10 x 18 feet nominal, 1 inches x 9-1/4 inches by 18 feet actual dimension.
    - i. 5/4 x 12 x 12 feet nominal, 1 inches x 11-1/4 inches by 12 feet actual dimension.
    - j. 5/4 x 12 x 18 feet nominal, 1 inches x 11-1/4 inches by 18 feet actual dimension.

### **2.03 ACCESSORIES**

- A. Fasteners: Stainless steel or hot-dip galvanized, with thin shank, blunt point, full round head as recommended by the manufacturer.
- B. Adhesives: a non-toxic, odorless, UV stable, water-based PVC cement.
- C. Sealants: Urethane, polyurethane or acrylic based sealants without silicone.

## **PART 1 EXECUTION**

### **3.01 EXAMINATION**

- A. Verification of Conditions: Examine areas and conditions under which Work is to be performed and identify conditions that may be detrimental to proper or timely completion.
- B. Do not proceed until unsatisfactory conditions have been corrected.

### **3.02 INSTALLATION**

- A. General: Install products in accordance with manufacturer's instructions, approved submittals, and in proper relationship with adjacent construction.
  1. Use manufacturer's recommended fasteners, not more than 2 inches from ends.
  2. Glue joints to eliminate joint separation.
  3. Allow for expansion and contraction at ends of the runs.

### **3.03 CLEANING AND PROTECTION**

- A. Protect from damage during construction operations. Promptly repair any damaged surfaces. Remove and replace work which cannot be satisfactorily repaired.
- B. Clean products, prior to Substantial Completion, using materials recommended by the manufacturer to remove stains, dirt and debris prior to final acceptance.

**END OF SECTION**

**SECTION 068316  
FIBERGLASS REINFORCED PANELING**

**PART 1 GENERAL**

**1.01 SECTION INCLUDES**

- A. Fiberglass reinforced plastic panels.
- B. Trim.

**1.02 REFERENCE STANDARDS**

- A. ASTM D5319 - Standard Specification for Glass-Fiber Reinforced Polyester Wall and Ceiling Panels; 2022.
- B. ASTM E84 - Standard Test Method for Surface Burning Characteristics of Building Materials; 2023c.

**1.03 SUBMITTALS**

- A. See Section 013000 - Administrative Requirements, for submittal procedures.
- B. Product Data: Provide data on specified products, describing physical and performance characteristics; including sizes, patterns and colors available; and installation instructions.
- C. Samples: Submit two samples illustrating material and surface design of panels.

**1.04 DELIVERY, STORAGE, AND HANDLING**

- A. Store panels flat, indoors, on a clean, dry surface. Remove packaging and allow panels to acclimate to room temperature for 48 hours prior to installation.

**PART 2 PRODUCTS**

**2.01 MANUFACTURERS**

- A. Fiberglass Reinforced Plastic Panels:
  - 1. Crane Composites, Inc: [www.cranecomposites.com/#sle](http://www.cranecomposites.com/#sle).
    - a. Product: Glasbord
  - 2. Substitutions: See Section 01 6000 - Product Requirements.

**2.02 PANEL SYSTEMS**

- A. Wall Panels:
  - 1. Panel Size: 4 by 8 feet (1.2 by 2.4 m).
  - 2. Panel Thickness: 0.09 inch (2.3 mm).
  - 3. Surface Design: Embossed.
  - 4. Color: As indicated on the drawings..
  - 5. Attachment Method: Adhesive only, with trim and sealant in joints.

**2.03 MATERIALS**

- A. Panels: Fiberglass reinforced plastic (FRP), complying with ASTM D5319.
  - 1. Surface Burning Characteristics: Maximum flame spread index of 25 and smoke developed index of 450; when system tested in accordance with ASTM E84.
- B. Trim: Stainless steel trims for corners and frame
- C. Adhesive: Type recommended by panel manufacturer.

**PART 3 EXECUTION**

**3.01 EXAMINATION**

- A. Verify existing conditions and substrate flatness before starting work.
- B. Verify that substrate conditions are ready to receive the work of this section.

**3.02 INSTALLATION - WALLS**

- A. Install panels in accordance with manufacturer's instructions.
- B. Cut and drill panels with carbide tipped saw blades, drill bits, or snips.



- C. Apply adhesive to the back side of the panel using trowel as recommended by adhesive manufacturer.
- D. Apply panels to wall with seams plumb and pattern aligned with adjoining panels.
- E. Install panels with manufacturer's recommended gap for panel field and corner joints.
- F. Place trim on panel before fastening edges, as required.
- G. Fill channels in trim with sealant before attaching to panel.
- H. Install trim with adhesive and screws or nails, as required.
- I. Seal gaps at floor, ceiling, and between panels with applicable sealant to prevent moisture intrusion.
- J. Remove excess sealant after paneling is installed and prior to curing.

**END OF SECTION**

**SECTION 071010  
GENERAL ROOFING CONSIDERATIONS**

**PART 1 GENERAL**

**1.01 SECTION INCLUDES**

- A. Information relative to different roof systems.
- B. Codes and Standards: All work to be in compliance with applicable requirements of governing authorities having jurisdiction.

**1.02 RELATED SECTIONS**

- A. Section 06 1000 - Rough Carpentry: for wood blocking and plywood.

**1.03 REFERENCES**

- A. Classification: Provide materials and methods that have been tested for application indicated for roof slopes shown and meet the following.
- B. Underwriters Laboratories Inc. (UL):
  - 1. Underwriters Laboratories Inc. (UL):
    - a. UL 790 for resistance to external fire spread for a Class "A" or "B" assembly. 2004
    - b. UL 263 for structural integrity and resistance to internal fire below the ceiling for a minimum 1 hour assembly rating and "P" suffix design identification. 2007
    - c. UL 1256 for resistance to internal fire spread below the deck. 2007

**1.04 SUBMITTALS**

- A. See Section 01300 - Administrative Requirements, for submittal procedures.
- B. Product Data: Submit manufacturer's product specifications, installation instructions and general recommendations for each principal roofing system product required. Include data substantiating that materials comply with requirements.
- C. Manufacturer's Certification: Obtain written certification from manufacturer of Flexible Sheet Roofing System (FSR) certifying that the manufacturer has reviewed the drawings and that the design meets their criteria for their guaranteed or warranted system. Provide a copy of this certification prior to start of Work.
- D. Installer Certification: Obtain written certification from manufacturer of Flexible Sheet Roofing System (FSR) certifying that Contractor is approved by manufacturer for installation of specified roofing system and that the Contractor is eligible to construct and repair any of the manufacturer's guaranteed or warranted systems. Provide copy of certification prior to start of Work.
- E. Prior to the award of Work, the Roofing Contractor shall submit, for approval by Architect, a written narrative of the Work to be accomplished and the methods and materials to execute same.
- F. Insulation Attachment Shop Drawing: Submit insulation fastening pattern at each site and each individual roof area based on design pressures indicated on roof plan. Provide the following information on a blank roof plan for each building (architect will provide blank roof plan (DWG format) upon request).
  - 1. Mechanical Attachment: Indicate fastener and plate type, size and fastener penetration depth as required for specific deck type attachment.

**1.05 QUALITY ASSURANCE**

- A. For project obtain roofing products from only one manufacturer. Provide secondary materials (and materials not available from primary roofing materials manufacturer) from sources which are recommended by manufacturer.
- B. Protect other work from spillage of roofing materials and prevent liquid materials from entering and clogging drains and conductors. Replace and restore other work, which is soiled or otherwise damaged by performance of roofing and associated work.

- C. Protection: All liquid petroleum gas equipment, man ladders and hoists shall be maintained in a safe condition. Fire extinguishers shall be posted near flammable adhesives and open flames. OSHA and other safety guidelines shall be observed for the Contractor's personnel and for the Owner's personnel.
- D. Reroofing: Remove only that portion of existing roofing (and insulation if any), which will be completely reroofed including insulation, related flashings and strippings the same day. Debris from removal operations shall be completely removed each day or confined to an approved waste container.
- E. Latent Elements: It shall be the responsibility of the Contractor to verify the presence (if any) and location of latent buried objects (e.g. electrical conduit, structural components, etc.) within an existing roofing system to be removed. Should there be any damage as a result of the Contractor removing an existing roofing system, it shall be the responsibility of the Contractor to repair the damage back to the original condition and the Owner accepts the responsibility for additional costs incurred. Any succeeding occurrences shall be the responsibility of the Contractor to repair the damage back to the original condition and the Contractor accepts the responsibility for additional costs incurred.
- F. Weather Condition Limitations: Proceed with roofing work only when existing and forecasted weather conditions will permit work to be performed in accordance with manufacturer's recommendations and warranty requirements.
- G. Installer: Shall be an "experienced" installer with successful experience in installation of roofing systems similar to those required for this project and acceptable to or licensed by manufacturer of primary roofing materials.
- H. Manufacturers with quality based contractor tier programs, provide bidders meeting only top tier requirements.
- I. Manufacturers are to provide weekly technical site visits throughout the project.

**1.06 PRE-INSTALLATION CONFERENCE**

- A. Preroofing Conference: Prior to installation of roofing and associated work, meet at project site, or other mutually agreed location, with Installer, roofing manufacturer, installers of related work, and other entities concerned with roofing performance, including (where applicable) Owner's insurer, test agencies, governing authorities, Architect, and Owner.

**1.07 SYSTEM DESIGNATION**

- A. The System Designation Chart that follows is intended as a quick reference tool for identification of different roofing systems:
- B. Flexible Sheet Roofing: I T A - FSR
  - 1. Substrate Type:
    - a. I: Insulated
  - 2. Sheet Type:
    - a. T: TPO (Thermoplastic Polyolefin)
  - 3. Attachment and/or Surfacing:
    - a. A: Adhered and Coated if Applicable

**PART 2 PRODUCTS (NOT APPLICABLE)**

**PART 3 EXECUTION (NOT APPLICABLE)**

**ROOFING CONTRACTOR'S MANUFACTURER'S CERTIFICATION**

**THE FOLLOWING IS REQUIRED FROM THE SPECIFIED ROOFING SYSTEM MANUFACTURER FOR EACH PROJECT WITH BID PACKAGE.**

Project  
Name: \_\_\_\_\_  
\_\_\_\_\_

Building's  
Name: \_\_\_\_\_  
\_\_\_\_\_  
\_\_\_\_\_

Be advised that as of this date \_\_\_\_\_,  
\_\_\_\_\_ certifies  
(name of manufacturer)

that they have reviewed the plans and specifications as prepared by MARTINRILEY, Inc.  
bearing commission number \_\_\_\_\_ and dated \_\_\_\_\_, with  
regard to the new or replacement roofing system at:

\_\_\_\_\_  
\_\_\_\_\_  
\_\_\_\_\_  
(name of building(s))

for \_\_\_\_\_  
(name of Owner)

\_\_\_\_\_ further certifies that  
(name of manufacturer)

the design meets the criteria for our guarantee or warranted system for the specified period.

\_\_\_\_\_  
(Manufacturer's Authorized Warranty Representative's Signature)

\_\_\_\_\_  
(Print or Type Name)

\_\_\_\_\_  
(Title)

Date: \_\_\_\_\_

**ROOFING CONTRACTOR'S INSTALLER'S CERTIFICATION**

**THE FOLLOWING IS REQUIRED FROM THE SPECIFIED ROOFING SYSTEM MANUFACTURER FOR EACH PROJECT WITH BID PACKAGE.**

Project  
Name: \_\_\_\_\_

Building's  
Name: \_\_\_\_\_

Be advised that as of this date \_\_\_\_\_, the following

Roofing  
Contractor \_\_\_\_\_

(contractor's name)

\_\_\_\_\_ is fully certified

(contractor's address)

to install and repair any and all roofing systems warranted and without warranty as offered by:

\_\_\_\_\_ (name of manufacturer)

\_\_\_\_\_  
(Manufacturer's Authorized Warranty Representative's Signature)

\_\_\_\_\_  
(Print or Type Name)

\_\_\_\_\_  
(Title)

Date: \_\_\_\_\_

**END OF SECTION**

**SECTION 072100  
THERMAL INSULATION**

**PART 1 GENERAL**

**1.01 SECTION INCLUDES**

- A. Board insulation and integral vapor retarder at perimeter foundation wall.
- B. Batt insulation in exterior wall construction.
- C. Batt insulation for filling perimeter window and door shim spaces and crevices in exterior wall and roof.
- D. Blown insulation for attics.

**1.02 RELATED REQUIREMENTS**

- A. Section 061000 - Rough Carpentry: Installation requirements for board insulation over steep slope roof sheathing or roof structure.

**1.03 REFERENCE STANDARDS**

- A. ASTM A653/A653M - Standard Specification for Steel Sheet, Zinc-Coated (Galvanized) or Zinc-Iron Alloy-Coated (Galvannealed) by the Hot-Dip Process; 2023.
- B. ASTM C578 - Standard Specification for Rigid, Cellular Polystyrene Thermal Insulation; 2023.
- C. ASTM C665 - Standard Specification for Mineral-Fiber Blanket Thermal Insulation for Light Frame Construction and Manufactured Housing; 2023.
- D. ASTM E84 - Standard Test Method for Surface Burning Characteristics of Building Materials; 2023c.
- E. ASTM E136 - Standard Test Method for Assessing Combustibility of Materials Using a Vertical Tube Furnace at 750 °C; 2022.
- F. NFPA 285 - Standard Fire Test Method for Evaluation of Fire Propagation Characteristics of Exterior Wall Assemblies Containing Combustible Components; 2023.

**1.04 SUBMITTALS**

- A. See Section 013000 - Administrative Requirements for submittal procedures.
- B. Product Data: Provide data on product characteristics, performance criteria, and product limitations.

**PART 2 PRODUCTS**

**2.01 APPLICATIONS**

- A. Insulation at Perimeter of Foundation: Extruded polystyrene (XPS) board.
- B. Insulation in Wood Framed Walls: Batt insulation with no vapor retarder.
- C. Insulation in Wood Framed Ceiling Structure: Blown-in insulation with no vapor retarder.
- D. Insulation Over Roof Deck: Extruded polystyrene (XPS) board.

**2.02 FOAM BOARD INSULATION MATERIALS**

- A. Extruded Polystyrene (XPS) Board Insulation: Complies with ASTM C578 with either natural skin or cut cell surfaces.
  - 1. Type and Compressive Resistance: Type IV, 25 psi (173 kPa), minimum.
  - 2. Flame Spread Index (FSI): Class A - 0 to 25, when tested in accordance with ASTM E84.
  - 3. Smoke Developed Index (SDI): 450 or less, when tested in accordance with ASTM E84.
  - 4. Type and Thermal Resistance, R-value (RSI-value): Type IV, 5.0 (0.88), minimum, per 1 inch (25.4 mm) thickness at 72 degrees F (\_\_\_\_) mean temperature.
  - 5. Complies with fire resistance requirements indicated on drawings as part of an exterior non-load-bearing exterior wall assembly when tested in accordance with NFPA 285.
  - 6. Board Size: 48 x 96 inch.
  - 7. Board Thickness: As indicated on drawings.
  - 8. Board Edges: Square.

9. Type and Water Absorption: Type XII, 0.3 percent by volume, maximum, by total immersion.
10. Products:
  - a. DuPont de Nemours, Inc; Styrofoam Brand Square Edge: [building.dupont.com/#sle](http://building.dupont.com/#sle).
  - b. Owens Corning Corporation; FOAMULAR Type \_\_\_\_ Extruded Polystyrene (XPS) Insulation: [www.ocbuildingspec.com/#sle](http://www.ocbuildingspec.com/#sle).
  - c. Substitutions: See Section 016000 - Product Requirements.

### 2.03 BATT INSULATION MATERIALS

- A. Glass Fiber Batt Insulation: Flexible preformed batt or blanket, complying with ASTM C665; friction fit.
  1. Flame Spread Index: 25 or less, when tested in accordance with ASTM E84.
  2. Smoke Developed Index: 50 or less, when tested in accordance with ASTM E84.
  3. Combustibility: Non-combustible, when tested in accordance with ASTM E136, except for facing, if any.
  4. Thermal Resistance/Thickness: As indicated on the Drawings.
  5. Facing: Unfaced.
  6. Products:
    - a. CertainTeed Corporation: [www.certainteed.com/#sle](http://www.certainteed.com/#sle).
    - b. Johns Manville: [www.jm.com/#sle](http://www.jm.com/#sle).
    - c. Owens Corning Corporation; EcoTouch PINK FIBERGLAS Insulation: [www.ocbuildingspec.com/#sle](http://www.ocbuildingspec.com/#sle).
    - d. Substitutions: See Section 016000 - Product Requirements.

### 2.04 ACCESSORIES

- A. Tape: Reinforced polyethylene film with acrylic pressure sensitive adhesive.
  1. Application: Sealing of interior circular penetrations, such as pipes or cables.
  2. Width: Are required for application.
- B. Flashing Tape: Special reinforced film with high performance adhesive.
  1. Application: Window and door opening flashing tape.
  2. Width: As required for application.
- C. Sill Plate Sealer: Closed-cell foam tape with rubberized adhesive membrane; bridges gap between foundation structure and sill plate or skirt board.
  1. Width: 6 inches (\_\_\_\_ mm).
  2. Ultraviolet (UV) and Weathering Resistance: Approved in writing by manufacturer for up to 30 days of weather exposure.
- D. Tape: Polyethylene self-adhering type, mesh reinforced, 2 inch (50 mm) wide.
- E. Insulation Fasteners: Impaling clip of unfinished steel with washer retainer and clips, to be adhered to surface to receive insulation, length to suit insulation thickness and substrate, capable of securely and rigidly fastening insulation in place.
- F. Nails or Staples: Steel wire; electroplated or galvanized; type and size to suit application.
- G. Wire Mesh: Galvanized steel, hexagonal wire mesh.
- H. Roof/Attic Insulation Baffle: Prefabricated ventilation channels for placement under roof sheathing with baffles to prevent wind-washing.
  1. Materials: Polyvinyl chloride (PVC)
  2. Roof Joist/Truss Spacing: Sized for trusses 24" C/C (field verify) length as to accommodate insulation height.
  3. Manufacturers:
    - a. Brentwood Industries, Inc.; Accuvent Original: [www.brentwoodindustries.com/#sle](http://www.brentwoodindustries.com/#sle)
    - b. Owens Corning Corporation; Raft-R-Mate: [www.ocbuildingspec.com/#sle](http://www.ocbuildingspec.com/#sle)
    - c. Substitutions: See Section 01 6000 - Product Requirements.

## **PART 3 EXECUTION**

### **3.01 EXAMINATION**

- A. Verify that substrate, adjacent materials, and insulation materials are dry and that substrates are ready to receive insulation.
- B. Verify substrate surfaces are flat, free of honeycomb, fins, irregularities, or materials or substances that may impede adhesive bond.

### **3.02 BOARD INSTALLATION AT FOUNDATION PERIMETER**

- A. Adhere a 6 inches (152 mm) wide strip of polyethylene sheet over construction, control, and expansion joints with double beads of adhesive each side of joint.
  - 1. Tape seal joints.
  - 2. Extend sheet full height of joint.
- B. Install boards per manufacturer's instructions on foundation perimeter.
  - 1. Place boards to maximize adhesive contact.
  - 2. Install in running bond pattern.
  - 3. Butt edges and ends tightly to adjacent boards and to protrusions.
- C. Cut and fit insulation tightly to protrusions or interruptions to the insulation plane.

### **3.03 BATT INSTALLATION**

- A. Install insulation and vapor retarder in accordance with manufacturer's instructions.
- B. Install in exterior wall and roof spaces without gaps or voids. Do not compress insulation.
- C. Trim insulation neatly to fit spaces. Insulate miscellaneous gaps and voids.
- D. Fit insulation tightly in cavities and tightly to exterior side of mechanical and electrical services within the plane of the insulation.
- E. Install with factory-applied vapor retarder membrane facing warm side of building spaces. Lap ends and side flanges of membrane over framing members.
- F. Staple or nail facing flanges in place at maximum 6 inches (152 mm) on center.
- G. Tape seal butt ends, lapped flanges, and tears or cuts in membrane.
- H. At metal framing, place vapor retarder on warm side of insulation; lap and seal sheet retarder joints over face of member
- I. Tape seal tears or cuts in vapor retarder.
- J. Extend vapor retarder tightly to full perimeter of adjacent window and door frames and other items interrupting the plane of the membrane; tape seal in place.

### **3.04 BLOWN-IN INSULATION**

- A. Examination
  - 1. Install insulation and ventilation baffle in accordance with ASTM C1015 and manufacturer's instructions.
  - 2. Verify that light fixtures have thermal cut-out device to restrict over-heating in soffit or ceiling spaces.
  - 3. Verify spaces are unobstructed to allow for proper placement of insulation.
- B. Ins
  - 1. Provide baffles extending from soffits to a minimum of six inches (6") above blown-in insulation.
  - 2. Provide blocking at wall extending to underside of baffle preventing blown insulation from entering soffit area.
  - 3. Blow insulation to the uniform height required to achieve R-value indicated.
- C. Cleaning
  - 1. Remove loose insulation residue.
- D. Schedules



1. Attic Spaces: Pour insulation between ceiling joists to achieve an R-value of 50.

### **3.05 PROTECTION**

- A. Do not permit installed insulation to be damaged prior to its concealment.

**END OF SECTION**

**SECTION 072600  
VAPOR BARRIER**

**PART 1 - GENERAL**

**1.01 SUMMARY**

- A. Products supplied under this section:
  - 1. Vapor barrier and installation accessories for installation under concrete slabs.
- B. Related sections:
  - 1. Section 03 3000 Cast-in-Place Concrete

**1.02 REFERENCES**

- A. American Society for Testing and Materials (ASTM):
  - 1. ASTM E 1745-11 Standard Specification for Plastic Water Vapor Retarders Used in Contact with Soil or Granular Fill Under Concrete Slabs.
  - 2. ASTM E 1643-11 Selection, Design, Installation, and Inspection of Water Vapor Retarders Used in Contact with Earth or Granular Fill Under Concrete Slabs.
- B. American Concrete Institute (ACI):
  - 1. ACI 302.2R-06 Guide for Concrete Slabs that Receive Moisture-Sensitive Flooring Materials.

**1.03 SUBMITTALS**

- A. Quality control/assurance:
  - 1. Summary of test results as per paragraph 9.3 of ASTM E 1745.
  - 2. Manufacturer's samples, literature.
  - 3. Manufacturer's installation instructions for placement, seaming and penetration repair instructions.
  - 4. All mandatory ASTM E1745 testing must be performed on a single production roll per ASTM E1745 Section 8.1.

**PART 2 - PRODUCTS**

**2.01 MATERIALS**

- A. Vapor barrier must have all of the following qualities:
  - 1. Permeance of less than 0.01 Perms [grains/(ft<sup>2</sup> - hr - inHg)] as tested in accordance with mandatory conditioning tests per ASTM E1745 Section 7.1 (7.1.1-7.1.5).
  - 2. Other performance criteria:
    - a. Strength: ASTM E 1745 Class A.
    - b. Thickness: 15 mils minimum

**2.02 B. VAPOR BARRIER PRODUCTS:**

- A. Basis of Design: Stego Industries LLC., Product: Stego Wrap Vapor Barrier (15-mil). [www.stegoindustries.com](http://www.stegoindustries.com)
- B. Reef Industries, Product: Vaporguard. [www.reefindustries.com](http://www.reefindustries.com)
- C. Sundance Inc., Product: Sundance VB 15 mil Vapor Barrier. [www.sundancepolymertech.com](http://www.sundancepolymertech.com)
- D. Substitutions: See Section 01 6000 - Product Requirements.

**2.03 ACCESSORIES**

- A. Seams:
  - 1. Stego Tape by Stego Industries LLC.
- B. Penetrations of vapor barrier:
  - 1. Stego Mastic by Stego Industries LLC.
  - 2. Stego Tape by Stego Industries LLC.
- C. Perimeter/edge seal:
  - 1. Stego Crete Claw by Stego Industries LLC.
  - 2. Stego Term Bar by Stego Industries LLC.

3. Stego Tack Tape (double sided) by Stego Industries LLC.

### **PART 3 - EXECUTION**

#### **3.01 PREPARATION**

- A. Ensure that base material is approved by Architect or Geotechnical Engineer.
  1. Level and compact base material.

#### **3.02 INSTALLATION**

- A. Install vapor barrier in accordance with manufacturer's instructions and ASTM E 1643.
  1. Unroll vapor barrier with the longest dimension parallel with the direction of the concrete placement and face laps away from the expected direction of the placement whenever possible.
  2. Extend vapor barrier over footings and grade beams to a distance acceptable to the Architect or stop at impediments such as dowels and waterstops
  3. Seal vapor barrier to slab perimeter/edge using Stego Crete Claw and remove dirt, debris, and mud from Crete Claw prior to concrete placement.
  4. Seal vapor barrier to footing/grade beam with double sided tape, termination bar, or both.
  5. Overlap joints 6 inches and seal with manufacturer's tape.
  6. Apply tape/Crete Claw to a clean and dry vapor barrier.
  7. Seal all penetrations (including pipes) per manufacturer's instructions.
  8. No penetration of the vapor barrier is allowed except for reinforcing steel and permanent utilities.
  9. Repair damaged areas by cutting patches of vapor barrier, overlapping damaged area 6 inches and taping all sides with tape.

**END OF SECTION**

**SECTION 074213.23  
METAL COMPOSITE MATERIAL WALL PANELS**

**PART 1 GENERAL**

**1.01 SECTION INCLUDES**

- A. Exterior cladding consisting of formed metal composite material (MCM) sheet, secondary supports, and anchors to structure, attached to solid backup.
- B. Matching flashing and trim.

**1.02 RELATED REQUIREMENTS**

- A. Section 072500 - Weather Barriers: Water-resistive barrier behind wall panel system.
- B. Section 076200 - Sheet Metal Flashing and Trim: Metal flashing components integrated with this wall system.
- C. Section 079200 - Joint Sealants: Sealing joints between siding and adjacent construction and fixtures.

**1.03 PRICE AND PAYMENT PROCEDURES**

- A. Alternates:
  - 1. See Section 012300 - Alternates for product alternates affecting this section.

**1.04 REFERENCE STANDARDS**

- A. AAMA 2605 - Voluntary Specification, Performance Requirements and Test Procedures for Superior Performing Organic Coatings on Aluminum Extrusions and Panels (with Coil Coating Appendix); 2022.
- B. ASTM B209/B209M - Standard Specification for Aluminum and Aluminum-Alloy Sheet and Plate; 2021a.
- C. ASTM B221 - Standard Specification for Aluminum and Aluminum-Alloy Extruded Bars, Rods, Wire, Profiles, and Tubes; 2021.
- D. ASTM B221M - Standard Specification for Aluminum and Aluminum-Alloy Extruded Bars, Rods, Wire, Profiles, and Tubes (Metric); 2021.
- E. ASTM D1781 - Standard Test Method for Climbing Drum Peel for Adhesives; 1998 (Reapproved 2021).
- F. ASTM D1929 - Standard Test Method for Determining Ignition Temperature of Plastics; 2023.
- G. ASTM E84 - Standard Test Method for Surface Burning Characteristics of Building Materials; 2023c.
- H. ASTM E330/E330M - Standard Test Method for Structural Performance of Exterior Windows, Doors, Skylights and Curtain Walls by Uniform Static Air Pressure Difference; 2014 (Reapproved 2021).
- I. NFPA 285 - Standard Fire Test Method for Evaluation of Fire Propagation Characteristics of Exterior Wall Assemblies Containing Combustible Components; 2023.

**1.05 SUBMITTALS**

- A. See Section 013000 - Administrative Requirements for submittal procedures.
- B. Product Data - MCM Sheets: Manufacturer's data sheets on each product to be used, including thickness, physical characteristics, and finish, and:
  - 1. Finish manufacturer's data sheet showing physical and performance characteristics.
  - 2. Storage and handling requirements and recommendations.
  - 3. Fabrication instructions and recommendations.
  - 4. Specimen warranty for finish, as specified herein.
- C. Product Data - Wall System: Manufacturer's data sheets on each product to be used, including:
  - 1. Physical characteristics of components shown on shop drawings.

2. Storage and handling requirements and recommendations.
  3. Installation instructions and recommendations.
  4. Specimen warranty for wall system, as specified herein.
- D. Shop Drawings: Show layout and elevations, dimensions and thickness of panels, connections, details and location of joints, sealants and gaskets, method of anchorage, support clips, exposed fasteners, number of anchors, supports, reinforcement, trim, flashings, and accessories.
1. Indicate panel numbering system.
  2. Differentiate between shop and field fabrication.
  3. Indicate substrates and adjacent work with which the wall system must be coordinated.
  4. Include large-scale details of anchorages and connecting elements.
  5. Include large-scale details or schematic, exploded or isometric diagrams to fully explain flashing at a scale of not less than 1-1/2 inches per 12 inches (1:10).
  6. Include design engineer's stamp or seal on shop drawings for attachments and anchors.
- E. Selection Samples: For each finish product specified, submit at least three sample color chips representing manufacturer's standard range of available colors and patterns.
1. Sealant Color: Color to match wall panels.
- F. Verification Samples: For each finish product specified, submit at least three samples, minimum size 12 inch (305 mm) square, and representing actual product in color and texture.
- G. Design Data: Submit structural calculations stamped by design engineer, for Architect's information and project record.
- H. Test Report: Submit test report verifying compliance with NFPA 285 for previously-tested exterior wall assembly.
- I. Testing agency's qualification statement.
- J. Maintenance Data: Care of finishes and warranty requirements.

#### **1.06 QUALITY ASSURANCE**

- A. Design Engineer's Qualifications: Design structural supports and anchorages under direct supervision of a Structural Engineer experienced in design of this type of work and licensed in the State in which the Project is located.
- B. Testing Agency Qualifications: Independent agency experienced in testing assemblies of the type required for this project and having the necessary facilities for full-size mock-up testing of the type specified.

#### **1.07 MOCK-UPS**

- A. See Section 014000 - Quality Requirements for additional requirements.
- B. Provide a mock-up for evaluation of fabrication workmanship.

#### **1.08 DELIVERY, STORAGE, AND HANDLING**

- A. See Section 017419 - Construction Waste Management and Disposal for packaging waste requirements.
- B. Deliver products in manufacturer's original, unopened, undamaged containers with identification labels intact.
  1. Protect finishes by applying heavy-duty removable plastic film during production.
  2. Package for protection against transportation damage.
  3. Provide markings to identify components consistently with drawings.
  4. Exercise care in unloading, storing, and installing panels to prevent bending, warping, twisting, and surface damage.
- C. Store products protected from exposure to harmful weather conditions and at temperature conditions recommended by manufacturer.
  1. Store in well-ventilated space out of direct sunlight.
  2. Protect from moisture and condensation with tarpaulins or other suitable weathertight covering installed to provide ventilation.

3. Store at a slope to ensure positive drainage of accumulated water.
4. Do not store in enclosed space where ambient temperature can exceed 120 degrees F (49 degrees C).
5. Avoid contact with other materials that might cause staining, denting, or other surface damage.

#### **1.09 WARRANTY**

- A. See Section 017800 - Closeout Submittals for additional warranty requirements.

### **PART 2 PRODUCTS**

#### **2.01 MANUFACTURERS**

- A. Wall Panel System Manufacturers:
  1. Engage Building Products; QuickPanel System: [www.easytrimreveals.com](http://www.easytrimreveals.com); 1-877-973-8746.
  2. Substitutions: See Section 016000 - Product Requirements.

#### **2.02 WALL PANEL SYSTEM**

- A. Wall Panel System: Metal panels, fasteners, and anchors designed to be supported by framing or other substrate provided by others; provide installed panel system capable of maintaining specified performance without defects, damage, or failure.
  1. Provide structural design by or under direct supervision of a Structural Engineer licensed in the State in which the Project is located.
  2. Provide panel jointing and weatherseal using a "wet", sealant-sealed system.
  3. Anchor panels to supporting framing without exposed fasteners.

#### **2.03 PERFORMANCE REQUIREMENTS**

- A. Thermal Movement: Provide for free and noiseless vertical and horizontal thermal movement due to expansion and contraction under material temperature range of minus 20 degrees F (minus 29 degrees C) to 180 degrees F (82 degrees C) without buckling, opening of joints, undue stress on fasteners, or other detrimental effects; allow for ambient temperature at time of fabrication, assembly, and erection procedures.
- B. Fire Performance: Use test method complying with NFPA 285.

#### **2.04 MATERIALS**

- A. Metal Composite Material (MCM) Sheet: Two sheets of aluminum sandwiching a core of extruded thermoplastic material; no foamed insulation material content.
  1. Overall Sheet Thickness: 0.118 inch (3 mm), minimum.
  2. Face Sheet Thickness: 0.019 inch (0.50 mm), minimum.
  3. Alloy: Manufacturer's standard, selected for best appearance and finish durability.
  4. Bond and Peel Strength: No adhesive failure of the bond between the core and the skin nor cohesive failure of the core itself below 22.4 inch-pound/inch (100 N-mm/mm) with no degradation in bond performance, when tested in accordance with ASTM D1781, simulating resistance to panel delamination, after 8 hours of submersion in boiling water and after 21 days of immersion in water at 70 degrees F (21 degrees C).
  5. Surface Burning Characteristics: Flame spread index of 25, maximum; smoke developed index of 450, maximum; when tested in accordance with ASTM E84.
  6. Flammability: Self-ignition temperature of 650 degrees F (343 degrees C) or greater when tested in accordance with ASTM D1929.
- B. Metal Framing Members: Include sub-girts, zee-clips, base and sill angles and channels, hat-shaped and rigid channels, and furring channels required for complete installation.
  1. Provide material strength, dimensions, configuration as required to meet applied loads and in compliance with applicable building code.
  2. Aluminum Components: ASTM B209/B209M; or ASTM B221 (ASTM B221M).

#### **2.05 FINISHES**

- A. Color/Texture: As selected by Architect from manufacturer's standard range.

## **PART 3 EXECUTION**

### **3.01 EXAMINATION**

- A. Examine dimensions, tolerances, and interfaces with other work.
  - 1. Verify that weather barrier system is properly installed; see Section 072500 for requirements.
- B. Examine substrate on-site to determine that conditions are acceptable for product installation in accordance with manufacturer's written instructions.
- C. If substrate preparation is the responsibility of another installer, notify Architect of unsatisfactory preparation before proceeding.
- D. Notify Architect in writing of conditions detrimental to proper and timely completion of work, and do not proceed with erection until unsatisfactory conditions have been corrected.

### **3.02 PREPARATION**

- A. Protect adjacent work areas and finish surfaces from damage during installation.

### **3.03 INSTALLATION**

- A. Do not install products that are defective, including warped, bowed, dented, and broken members, and members with damaged finishes.
- B. Comply with instructions and recommendations of MCM sheet manufacturer and wall system manufacturer, as well as with approved shop drawings.
- C. Install wall system securely allowing for necessary thermal and structural movement; comply with wall system manufacturer's instructions for installation of concealed fasteners.
- D. Do not handle or tool products during erection in manner that damages finish, decreases strength, or results in visual imperfection or failure in performance. Return component parts that require alteration to shop for refabrication, if possible, or for replacement with new parts.
- E. Do not form panels in field unless required by wall system manufacturer and approved by the Architect; comply with MCM sheet manufacturer's instructions and recommendations for field forming.
- F. Separate dissimilar metals; use gasket fasteners, isolation shims, or isolation tape where needed to eliminate possibility of electrolytic action between metals.
- G. Where joints are designed for field-applied sealant, seal joints completely with specified sealant.
- H. Install square, plumb, straight, and true, accurately fitted, with tight joints and intersections maintaining the following installation tolerances:
  - 1. Variation From Plane or Location: 1/2 inch in 30 feet (10 mm in 10 m) of length and up to 3/4 inch in 300 feet (20 mm in 100 m), maximum.
  - 2. Deviation of Vertical Member From True Line: 0.1 inch in 25 feet (3 mm in 9 m) run, maximum.
  - 3. Deviation of Horizontal Member From True Line: 0.1 inch in 25 feet (3 mm in 9 m) run, maximum.
  - 4. Offset From True Alignment Between Two Adjacent Members Abutting End To End, In Line: 0.03 inch (0.75 mm), maximum.
- I. Replace damaged products.

### **3.04 CLEANING**

- A. See Section 017000 - Execution and Closeout Requirements for additional requirements.
- B. Ensure weep holes and drainage channels are unobstructed and free of dirt and sealants.
- C. Remove protective film after installation of joint sealers, after cleaning of adjacent materials, and immediately prior to completion of work.
- D. Remove temporary coverings and protection of adjacent work areas.
- E. Clean installed products in accordance with manufacturer's instructions.

**3.05 PROTECTION**

- A. Protect installed panel system from damage until Date of Substantial Completion.

**END OF SECTION**



**SECTION 074616  
ALUMINUM SIDING**

**PART 1 GENERAL**

**1.01 SECTION INCLUDES**

- A. Aluminum Soffit Panels
- B. Trim, flashings, accessories, and fasteners for aluminum soffit.

**1.02 RELATED REQUIREMENTS**

- A. Section 076200 - Sheet Metal Flashing and Trim: Metal flashings and trim associated with metal siding.
- B. Section 079200 - Joint Sealants: Sealing joints between siding, adjacent construction, and fixtures.

**1.03 REFERENCE STANDARDS**

- A. AAMA 609 & 610 - Cleaning and Maintenance Guide for Architecturally Finished Aluminum (Combined Document); 2015.
- B. ASTM A653/A653M - Standard Specification for Steel Sheet, Zinc-Coated (Galvanized) or Zinc-Iron Alloy-Coated (Galvannealed) by the Hot-Dip Process; 2023.
- C. ASTM B209/B209M - Standard Specification for Aluminum and Aluminum-Alloy Sheet and Plate; 2021a.

**1.04 SUBMITTALS**

- A. See Section 013000 - Administrative Requirements for submittal procedures.
- B. Product Data: Manufacturer's data sheets on each product to be used, including:
  - 1. Preparation instructions and recommendations.
  - 2. Siding materials, underlayment, flashings, fasteners and accessories.
  - 3. Dimensions, physical properties, and typical details.
  - 4. Storage and handling requirements and recommendations.
  - 5. Installation instructions and recommendations.
- C. Samples: For each finish product specified, provide two complete sets of color chips representing manufacturer's full range of available colors and patterns, including the following:
  - 1. Siding: Two of each type; full panel width by 12 inches (305 mm) long.
- D. Manufacturer's qualification statement.
- E. Installer's qualification statement.

**1.05 QUALITY ASSURANCE**

- A. Manufacturer Qualifications: Company specializing in manufacturing products specified in this section, with not less than five years of documented experience.
- B. Installer Qualifications: Company specializing in performing work of the type specified and with at least five years of documented experience.

**1.06 DELIVERY, STORAGE, AND HANDLING**

- A. See Section 017419 - Construction Waste Management and Disposal for packaging waste requirements.
- B. Deliver and store products in manufacturer's unopened packaging bearing brand name and manufacturer's identification until ready for installation.
- C. Verify quantities and condition immediately upon receipt; remove damaged materials from site, and coordinate with manufacturer to replace with new materials meeting specified requirements.
- D. Store products off the ground, within manufacturer's temperature and environmental limits, away from moisture, protected from traffic and construction activities, and minimize on-site storage prior to installation.

## **1.07 FIELD CONDITIONS**

- A. Do not install siding when air temperature or relative humidity are outside manufacturer's limits.

## **PART 2 PRODUCTS**

### **2.01 MANUFACTURERS**

- A. Aluminum Siding Manufacturers:
  - 1. Vented Soffit: Decomesh, Soffit Venting System; [www.bestmaterials.com](http://www.bestmaterials.com).
  - 2. Non-Vented Soffit: Quality Edge, TRULINE HP Soffit System; [www.QualityEdge.com](http://www.QualityEdge.com).
  - 3. Substitutions: See Section 016000 - Product Requirements.

### **2.02 ALUMINUM SIDING**

- A. Type Non-Vented, Aluminum Soffit, TRULINE HP Double 5" Soffit - Solid
  - 1. Material: Precoated Aluminum Sheet, 0.019 inch, minimum base metal thickness
  - 2. Dimensions: 10 inch wide by 12 feet long.
  - 3. Manufacturer SKU: D5SS
  - 4. Soffit Accessories: Provide coordinating accessories made of same material as required for complete and proper installation.
    - a. F-channel trim.
    - b. J-channel trim.

### **2.03 MATERIALS**

- A. Precoated Aluminum Sheet: ASTM B209/B209M, 3105 alloy, O temper, with smooth surface texture; continuous-coil-coated on exposed surfaces with indicated finish coating, and manufacturer's standard panel back coating.

### **2.04 ACCESSORIES**

- A. Fasteners: Aluminum; nonstaining, of size and strength to securely and rigidly retain this work; prefinished to match siding finish.
- B. Flashing: Siding manufacturer's standard, factory-finished flashing accessories.
- C. Provide coordinating accessories made of same material as required for complete and proper installation whether or not specifically indicated on drawings.
  - 1. J-Channels.

### **2.05 FINISHES**

- A. Vented Soffit: Polyester Baked on Enamel
  - 1. Color: White
  - 2. Texture: Smooth
- B. Non-Vented Soffit: Q800 TuffTech
  - 1. Color: 280 White [W]
  - 2. Texture: Smooth

## **PART 3 EXECUTION**

### **3.01 EXAMINATION**

- A. Examine substrate conditions before beginning installation.
- B. Verify dimensions and acceptable substrate condition.
- C. If substrate preparation is responsibility of another installer, notify Architect of unsatisfactory conditions before proceeding.
- D. Do not proceed with installation until unacceptable conditions have been corrected.

### **3.02 PREPARATION**

- A. Surface Preparation: Prepare surfaces as recommended by manufacturer.
- B. Protect surrounding areas and adjacent surfaces during execution of this work.

### **3.03 INSTALLATION**

- A. Install aluminum soffit and accessories in accordance with manufacturer's written instructions.
- B. Attach siding using manufacturers recommended fasteners, sealants, and adhesives, allowing for thermal expansion.
- C. Exterior Soffit Vents: Install according to manufacturer's written instructions; provide vent area specified.
- D. Install joint sealants to ensure watertight conditions; see Section 079200.
- E. Where dissimilar materials are in contact, prevent galvanic action as recommended by manufacturer.

### **3.04 CLEANING**

- A. See Section 017000 - Execution and Closeout Requirements for additional requirements.
- B. Remove grease and oil films, excess joint sealer, handling marks, and other installation debris from aluminum siding, leaving siding clean and unmarked, free from dents, creases, waves, scratch marks, or other damage to material finishes.
- C. Upon completion of installation, thoroughly clean prefinished aluminum surfaces in accordance with AAMA 609 & 610.
- D. Remove excess materials and debris from project site.

### **3.05 PROTECTION**

- A. Protect installed products until completion of project.
- B. Touch-up, repair or replace damaged products before Date of Substantial Completion.

**END OF SECTION**

**SECTION 074646  
FIBER CEMENT SIDING**

**PART 1 GENERAL**

**1.01 SECTION INCLUDES**

- A. Fiber cement lap siding, panels, shingle, trim, fascia, moulding, and accessories; James Hardie HZ10 Engineered for Climate Siding and Hardie Architectural Panels.

**1.02 RELATED SECTIONS**

- A. Section 06 10 00 - Rough Carpentry.

**1.03 REFERENCES**

- A. ASTM D3359 - Standard Test Method for Measuring Adhesion by Tape Test, Tool and Tape.
- B. ASTM E136 - Standard Test Method for Behavior of Materials in a Vertical Tube Furnace at 750 degrees C.

**1.04 SUBMITTALS**

- A. Submit under provisions of Section 01 30 00 - Administrative Requirements.
- B. Product Data: Manufacturer's data sheets on each product to be used, including:
  - 1. Preparation instructions and recommendations.
  - 2. Storage and handling requirements and recommendations.
  - 3. Installation methods.
- C. Shop Drawings: Provide detailed drawings of atypical non-standard applications of cementitious siding materials which are outside the scope of the standard details and specifications provided by the manufacturer.
- D. Selection Samples: For each finish product specified, two complete sets of color chips representing manufacturer's full range of available colors and patterns.
- E. Verification Samples: For each finish product specified, two samples, minimum size 4 by 6 inches (100 by 150 mm), representing actual product, color, and patterns.

**1.05 QUALITY ASSURANCE**

- A. Installer Qualifications: Minimum of 2 years' experience with installation of similar products.
- B. Mock-Up: Provide a mock-up for evaluation of surface preparation techniques and application workmanship.
  - 1. Finish areas designated by Architect.
  - 2. Do not proceed with remaining work until workmanship, color, and sheen are approved by Architect.
  - 3. Remodel mock-up area as required to produce acceptable work.

**1.06 DELIVERY, STORAGE, AND HANDLING**

- A. Store products in manufacturer's unopened packaging until ready for installation.
- B. Store siding on edge or lay flat on a smooth level surface. Protect edges and corners from chipping. Store sheets under cover and keep dry prior to installing.
- C. Store and dispose of solvent-based materials, and materials used with solvent-based materials, in accordance with requirements of local authorities having jurisdiction.

**1.07 PROJECT CONDITIONS**

- A. Maintain environmental conditions (temperature, humidity, and ventilation) within limits recommended by manufacturer for optimum results. Do not install products under environmental conditions outside manufacturer's absolute limits.

**1.08 WARRANTY**

- A. Product Warranty: Limited, non-pro-rated product warranty.
  - 1. Hardie Architectural Panels for 30 years.
- B. Finish Warranty: Limited product warranty against manufacturing finish defects.

1. When used for its intended purpose, properly installed and maintained according to Hardie's published installation instructions, James Hardie's ColorPlus finish with ColorPlus Technology, for a period of 15 years from the date of purchase: will not peel; will not crack; and will not chip. Finish warranty includes the coverage for labor and material.

C. Workmanship Warranty: Application limited warranty for 2 years.

## **PART 2 PRODUCTS**

### **2.01 MANUFACTURERS**

- A. Acceptable Manufacturer: James Hardie Building Products, Inc., which is located at: 231 S. La Salle St. Suite 2000; Chicago, IL 60604; Toll Free Tel: 877-236-7526; Email: request info (info@jameshardie.com); Web: <https://www.jameshardiepros.com> | <https://www.jameshardie.com>
- B. Requests for approval of equal substitutions will be considered in accordance with provisions of Section 01 60 00 - Product Requirements.

### **2.02 SIDING AND TRIM**

- A. Hardie Architectural Panels as manufactured by James Hardie Building Products, Inc. A non-combustible fiber-cement panel.
  1. Product Composition: Grade II, Type A, fiber-cement sheets as defined by ASTM C1186. manufactured by the Hatschek process and cured by high pressure steam autoclaving.
  2. Code Compliance:
    - a. International Building Code (IBC).
      - 1) Section 1404.10: 2009, 2012 and 2015.
      - 2) Section 1403.10: 2018.
    - b. Wind Design:
      - 1) Manufacturer's readily available design load and exposure category tables are derived from testing in accordance with ASTM E 330.
      - 2) Wind speed design coefficient assumptions per Analytical Method in ASCE 7.
  3. Fire Characteristics:
    - a. Tested in Accordance with ASTM E136: Classified as non-combustible.
    - b. May be used in ASTM E119 fire resistance rated assemblies as listed by Warnock Hersey.
    - c. Class A Material: Per FBC 2017 and 2020, and 2018 IBC Section 803.1.1 Surface Burning Characteristics when tested in accordance with ASTM E84:
      - 1) Flame Spread Index : 0. Smoke Developed Index: 0.
  4. Type: Hardie Architectural Panels - Fine Sand 4 by 8 feet (1219 by 2438 mm).
  5. Type: Hardie Architectural Panels - Fine Sand 4 by 10 feet (1219 by 3048 mm).
  6. Type: Hardie Architectural Panels - Fine Sand 4 by 12 feet (1219 by 3658 mm).
  7. Physical Properties:
    - a. Test Method ASTM C1185: Passed.
      - 1) Dimensional Tolerances.
        - (a) Length: Plus or minus 0.5 percent or plus or minus 1/4 inch (6 mm).
        - (b) Width: Plus or minus 0.5 percent or plus or minus 1/4 inch (6 mm),
        - (c) Thickness: Plus or minus 0.04 inch (1 mm).
        - (d) Squareness: Less than 1/32 inches per ft (2.6 mm per m) of length.
        - (e) Edge Straightness: Less than 1/32 inches per ft (2.6 mm per m) of length.
      - 2) Density: Less than 83 pounds per sq ft (4 kPa).
      - 3) Water Tightness: No drop formation; Pass.
      - 4) Flexural strength:
        - (a) Wet Conditioned, psi: Greater than 1015 psi (7 MPa); Pass.
        - (b) Equilibrium Conditioned, psi: Greater than 1450 psi (10 MPa); Pass.
      - 5) Warm Water Resistance, Observations: No structural alteration; Pass.
      - 6) Heat / Rain Resistance:
        - (a) Physical Observations Mass: No structural alteration; Pass.
        - (b) Loss Percentage: Less than or equal to 3.0 percent; Pass..

- (c) Freeze/Thaw, percent strength retention: Greater than or equal to 80 percent; Pass.
  - b. Fire Characteristics:
    - 1) ASTM E84: Surface Burning Characteristics
      - (a) Flame Spread Index (FSI) Smoke: 0.
      - (b) Developed Index (SDI): 0.
      - (c) Fuel Contributed: 0.
      - (d) International Building Code: A.
    - 2) ASTM E136: Non-combustibility: Pass.
- 8. Trim Accessories:
  - a. J Trim: Aluminum extrusion to be used as a trim at abutments; soffits, masonry, windows, etc.
  - b. Low-Profile Inside Corner Trim: Aluminum extrusion to be used for inside corners.
  - c. Inside Corner Trim: Aluminum extrusion to be used for inside corners.
  - d. Low-Profile Outside Corner Trim: Aluminum extrusion to be used for outside corners.
  - e. Low Profile 45 degrees Inside Corner Trim: Aluminum extrusion to be used for bay windows.
  - f. Low Profile 45 degrees Outside Corner Trim: Aluminum extrusion to be used for bay windows.
  - g. Vertical T Trim: Aluminum extrusion to be used along vertical butt joints. For horizontal panel orientations only.
  - h. Vertical H Trim: Aluminum extrusion to be used along vertical butt joints. For horizontal panel orientations only.
  - i. Horizontal Angled T Flashing Trim: Aluminum extrusion to be used along horizontal control joints.
  - j. Horizontal Z Flashing Trim: Aluminum extrusion to be used along horizontal control joints.
  - k. Base Trim: Aluminum extrusion to be used as a base edge solution.
  - l. Base Outside Corner Trim: To be used as an outside corner connection for Base trim.
  - m. Base Inside Corner Trim: To be used as an inside corner connection for Base trim.
  - n. Base Joints: To be used to connect Base trims.

## **2.03 FASTENERS**

- A. Wood Framing Fasteners:
  - 1. Provide manufacturer recommended wood framing fasteners for each intended use.

## **2.04 FINISHES**

- A. Factory Primer: Provide factory applied universal primer.
  - 1. Primer: Factory primed by James Hardie.
  - 2. Topcoat: To be selected by Architect.

## **PART 3 EXECUTION**

### **3.01 EXAMINATION**

- A. Do not begin installation until substrates have been properly prepared.
- B. If framing preparation is the responsibility of another installer, notify Architect of unsatisfactory preparation before proceeding.
- C. Nominal 2 inch by 4 inch (51 mm by 102 mm) wood framing selected for minimal shrinkage and complying with local building codes, including the use of water-resistive barriers or vapor barriers where required. Minimum 1-1/2 inches (38 mm) face and straight, true, of uniform dimensions and properly aligned.
  - 1. Install water-resistive barriers and claddings to dry surfaces.
  - 2. Repair any punctures or tears in the water-resistive barrier prior to the installation of the siding.
  - 3. Protect siding from other trades.

- D. Minimum 20 gauge (1 mm) 3-5/8 inch (92 mm) C-Stud 16 inches maximum on center or 16 gauge (1.6 mm) 3-5/8 inches (92 mm) C-Stud 24 inches (610 mm) maximum on center metal framing complying with local building codes, including the use of water-resistive barriers and/or vapor barriers where required. Minimum 1-1/2 inches (38 mm) face and straight, true, of uniform dimensions and properly aligned.
  - 1. Install water-resistive barriers and claddings to dry surfaces.
  - 2. Repair any punctures or tears in the water-resistive barrier prior to the installation of the siding.
  - 3. Protect siding from other trades.

### **3.02 PREPARATION**

- A. Clean surfaces thoroughly prior to installation.
- B. Prepare surfaces using the methods recommended by the manufacturer for achieving the best result for the substrate under the project conditions.
- C. Install a water-resistive barrier is required in accordance with local building code requirements.
- D. The water-resistive barrier must be appropriately installed with penetration and junction flashing in accordance with local building code requirements.
- E. Install Engineered for Climate HardieWrap weather barrier in accordance with local building code requirements.
- F. Use HardieWrap Seam Tape and joint and laps.
- G. Install and HardieWrap flashing, HardieWrap Flex Flashing.

### **3.03 INSTALLATION - HARDIE ARCHITECTURAL PANELS**

- A. Install materials in strict accordance with manufacturer's installation instructions.
- B. Install over braced wood. See General Fastening Requirements. Irregularities in framing and sheathing can mirror through the finished application. Correct irregularities before installing siding.
- C. A water-resistive barrier (WRB) is required in accordance with local building code requirements. The water-resistive barrier must be appropriately installed with penetration and junction flashing in accordance with local building code requirements. James Hardie will assume no responsibility for water infiltration. James Hardie does manufacture HardieWrap Weather Barrier, a non-woven non-perforated housewrap, which complies with building code requirements.
- D. When installing horizontally, a WRB with min. 90 percent drainage efficiency shall be used.
- E. Adjacent finished grade must slope away from the building in accordance with local building codes - typically a minimum of 6 in. in the first 10 ft.
- F. Do not use Hardie Architectural Panels in Fascia or Trim applications.
- G. Do not install that product remains in contact with standing water.
- H. Installed on flat vertical wall applications only.
- I. For larger projects where the span of the wall is significant in length, the designer and/or architect should take into consideration the coefficient of thermal expansion and moisture movement of the product in their design. These values can be found in the Technical Bulletin "Expansion Characteristics of James Hardie Siding Products" at [www.jameshardie.com](http://www.jameshardie.com).
- J. James Hardie Building Products provides installation /wind load information for buildings with a maximum mean roof height of 85 feet. For information on installations above 60 feet, please contact JH technical support.
- K. Minimum standard panel design size is 12 x 16 inches ( ). Panels may be notched and cut to size to fit between windows, doors, corners, etc.

### **3.04 INSTALLATION - HARDIESOFFIT HZ10 AND VENTED PANELS**

- A. Install materials in strict accordance with manufacturer's installation instructions.

1. Panels may be installed as soffit or ceiling over wood or steel framing; 20 gauge (33 mils) minimum to 16 gauge (54 mils), complying with local building code. Install soffits to nominal 2 x 4 framing members spaced a maximum of 24 inches (610 mm) on center with the long dimension perpendicular to the rafter or joist framing.
2. Support edges by framing.
3. Install water barriers and air barriers as required by local building codes.
4. Ensure gutters have end caps. Maintain a minimum 1 inch (25 mm) gap between end caps and siding and trim.
5. Install kickout flashing at roof-wall junctions per manufacturer's instructions.
6. Additional framing may be needed to ensure proper fastening.
7. Position vent holes toward outside of eave for optimal airflow.
8. Vents can be installed into non-vented soffit.
9. Insect screen can be installed using construction adhesive.
10. Fastener Positioning: Position fasteners 3/8 inches (9.5 mm) from panel edges and no closer than 2 inches (51 mm) away from corners when using soffit greater than 12 inch (305 mm) wide and no closer than 1 inch (25 mm) away from corners when using soffit that is less than or equal to 12 inch (305 mm) wide.
11. Jointing Methods: Install panels in moderate contact at ends, provide PVC or metal jointers, battens or leave appropriate gap and caulk.
12. Drive fasteners perpendicular to siding and framing.
13. Fastener heads should fit snug against siding; no air space.

### **3.05 INSTALLATION - HARDIE HZ10 SHINGLESIDE CLADDING**

- A. Install materials in strict accordance with manufacturer's installation instructions.
- B. Substrate: Install a minimum 7/16 inch (11 mm) thick OSB wall sheathing or equivalent braced walls complying with applicable building codes.
- C. Starting: Install a minimum 1/4 inch (6 mm) thick lath starter strip at the bottom course of the wall.
- D. Maintain clearance between siding and adjacent finished grade.
- E. Apply starter course of 10 inches (254 mm) shingles or 9-1/2 inches (241 mm) lap siding overlapping the starter strip.
- F. Apply subsequent courses horizontally with a minimum 10 inch overlap at the top and a minimum 2 inch (51 mm) side lap. The bottom edge of the first two courses overlaps the starter strip.
- G. Fasten between 1/2 inch (13 mm) and 1 inch (25 mm) in from the side edge and between 8-1/2 inches (216 mm) and 9 inches (229 mm) up from the shingle bottom edge.
- H. Allow minimum vertical clearance between the edge of siding and any other material in strict accordance with the manufacturer's installation instructions.
- I. Ensure vertical joints of overlapping shingle course do not align.
- J. Wind Resistance: Where a specified level of wind resistance is required, Hardie Shingle siding is installed to substrate and secured with a minimum two fasteners described in Table No. 6, 7 and 8 in National Evaluation Service Report No. NER-405.

### **3.06 INSTALLATION - HARDIETRIM HZ10 BOARDS**

- A. Install materials in strict accordance with manufacturer's installation instructions. Install flashing around all wall openings.
- B. Fasten through trim into structural framing or code complying sheathing. Fasteners must penetrate minimum 3/4 inch (19 mm) or full thickness of sheathing. Additional fasteners may be required to ensure adequate security.
- C. Place fasteners no closer than 3/4 inch (19 mm) and no further than 2 inches (51 mm) from side edge of trim board and no closer than 1 inch (25 mm) from end. Fasten maximum 16 inches (406 mm) on center.



- D. Maintain clearance between trim and adjacent finished grade.
- E. Trim inside corner with a single board trim both side of corner.
- F. Outside Corner Board Attach Trim on both sides of corner with 16 gage corrosion resistant finish nail 1/2 inch (13 mm) from edge spaced 16 inches (406 mm) apart, weather cut each end spaced minimum 12 inches (305 mm) apart.
- G. Allow 1/8 inch gap between trim and siding.
- H. Seal gap with high quality, paint-able caulk.
- I. Shim frieze board as required to align with corner trim..
- J. Fasten through overlapping boards. Do not nail between lap joints.
- K. Overlay siding with single board of outside corner board then align second corner board to outside edge of first corner board. Do not fasten HardieTrim boards to HardieTrim boards.
- L. Shim frieze board as required to align with corner trim.
- M. Install HardieTrim Fascia boards to rafter tails or to sub fascia.

### **3.07 FINISHING**

- A. Finish unprimed siding with a minimum one coat high quality, alkali resistant primer and one coat of either, 100 percent acrylic or latex or oil based, exterior grade topcoats or two coats high quality alkali resistant 100 percent acrylic or latex, exterior grade topcoat within 90 days of installation. Follow paint manufacturer's written product recommendation and written application instructions.
- B. Finish factory primed siding with a minimum of one coat of high quality 100 percent acrylic or latex or oil based exterior grade paint within 180 days of installation. Follow paint manufacturer's written product recommendation and written application instructions.

### **3.08 PROTECTION**

- A. Protect installed products until completion of project.
- B. Touch-up, repair or replace damaged products before Substantial Completion.

**END OF SECTION**

**SECTION 075400  
THERMOPLASTIC MEMBRANE ROOFING**

**PART 1 GENERAL**

**1.01 SECTION INCLUDES**

- A. Mechanically attached system with thermoplastic roofing membrane.
- B. Insulation, flat and tapered.
- C. Cover boards.
- D. Flashings.

4

**1.02 RELATED REQUIREMENTS**

- A. Section 061000 - Rough Carpentry: Wood nailers and curbs.
- B. Section 076200 - Sheet Metal Flashing and Trim: Counterflashings and reglets.
- C. Section 077100 - Roof Specialties: Prefabricated roofing expansion joint flashing.

**1.03 REFERENCE STANDARDS**

- A. ASCE 7 - Minimum Design Loads and Associated Criteria for Buildings and Other Structures; Most Recent Edition Cited by Referring Code or Reference Standard.
- B. ASTM C1177/C1177M - Standard Specification for Glass Mat Gypsum Substrate for Use as Sheathing; 2017.
- C. ASTM C1289 - Standard Specification for Faced Rigid Cellular Polyisocyanurate Thermal Insulation Board; 2023a.
- D. ASTM D6878/D6878M - Standard Specification for Thermoplastic Polyolefin-Based Sheet Roofing; 2021.
- E. FM (AG) - FM Approval Guide; Current Edition.
- F. FM DS 1-28 - Wind Design; 2015, with Editorial Revision (2022).
- G. NRCA (RM) - The NRCA Roofing Manual; 2017.
- H. NRCA (WM) - The NRCA Waterproofing Manual; 2005.
- I. UL (DIR) - Online Certifications Directory; Current Edition.
- J. UL (FRD) - Fire Resistance Directory; Current Edition.

**1.04 ADMINISTRATIVE REQUIREMENTS**

- A. Preinstallation Meeting: Convene one week before starting work of this section.
  - 1. Review preparation and installation procedures and coordinating and scheduling required with related work.

**1.05 SUBMITTALS**

- A. See Section 013000 - Administrative Requirements for submittal procedures.
- B. Product Data: Provide data indicating membrane materials, flashing materials, insulation, surfacing, and fasteners.
- C. Manufacturer's Certificate: Certify that products meet or exceed specified requirements.
- D. Manufacturer's Installation Instructions: Indicate membrane seaming precautions and perimeter conditions requiring special attention.
- E. Manufacturer's qualification statement.
- F. Installer's qualification statement.
- G. Warranty: Submit manufacturer warranty and ensure forms have been completed in Owner's name and registered with manufacturer.

## 1.06 QUALITY ASSURANCE

- A. Manufacturer Qualifications: Company specializing in manufacturing products specified in this section with minimum three years of documented experience.
- B. Installer Qualifications: Company specializing in performing the work of this section with at least three years of documented experience and approved by manufacturer.

## 1.07 DELIVERY, STORAGE, AND HANDLING

- A. Deliver materials in manufacturer's original containers, dry and undamaged, with seals and labels intact.
- B. Store materials in weather protected environment, clear of ground and moisture.
- C. Ensure storage and staging of materials does not exceed static and dynamic load-bearing capacities of roof decking.
- D. Protect foam insulation from direct exposure to sunlight.

## 1.08 FIELD CONDITIONS

- A. Do not apply roofing membrane during unsuitable weather.
- B. Do not apply roofing membrane when ambient temperature is below 40 degrees F (5 degrees C) or above 120 degrees F (\_\_\_\_ degrees C).
- C. Do not apply roofing membrane to damp or frozen deck surface or when precipitation is expected or occurring.
- D. Do not expose materials vulnerable to water or sun damage in quantities greater than can be weatherproofed the same day.
- E. Schedule applications so that no partially completed sections of roof are left exposed at end of workday.

## 1.09 WARRANTY

- A. Roofing Contractor's Warranty: Provide roofing contractor's "Roofing Warranty" typical in form and content indicated by Midwest Roofing Contractors Association, Inc. approved guarantee form no. 2007, 2-years as indicated on form.
- B. Manufacturer's Warranty: Provide flexible sheet roofing manufacturer's standard unlimited product and contractor workmanship liability "Roofing Manufacturer's Basic Roofing Guarantee" from date of substantial completion against leaks caused by defective materials or workmanship and against normal wear and tear for the following period of time with respect to the following system designations
  - 1. ITA 30-year No Dollar Limit (NDL)

## PART 2 PRODUCTS

### 2.01 MANUFACTURERS

- A. Thermoplastic Polyolefin (TPO) Membrane Roofing Materials:
  - 1. Carlisle Roofing Systems, Inc; Sure-Weld TPO - 80mil: [www.carlisle-syntec.com/#sle](http://www.carlisle-syntec.com/#sle).
  - 2. Firestone Building Products, LLC; Ultraply TPO Platinum Membrane (80 mil): [www.firestonebpco.com/#sle](http://www.firestonebpco.com/#sle).
  - 3. Johns Manville; JM TPO - 80 Mil: [www.jm.com/#sle](http://www.jm.com/#sle).
  - 4. Substitutions: See Section 016000 - Product Requirements.
- B. Thermoplastic Polyvinyl Chloride (PVC) Membrane Roofing Materials:
  - 1. Sika Corporation Roofing; Sarnafil S 327-80: [usa.sika.com/sarnafil/#sle](http://usa.sika.com/sarnafil/#sle).
  - 2. Substitutions: See Section 016000 - Product Requirements.

### 2.02 MEMBRANE ROOFING AND ASSOCIATED MATERIALS

- A. Membrane Roofing Materials:
  - 1. PVC: Polyvinyl chloride (PVC) complying with ASTM D4434/D4434M, Type II, sheet contains reinforcing fibers or reinforcing fabrics.
    - a. Thickness: 80 mil, 0.080 inch (2 mm), minimum.

- b. The manufacturer to guarantee that the membrane thickness meets or exceeds the specified thickness when tested in accordance to ASTM D751
  - 2. TPO: Thermoplastic polyolefin (TPO) complying with ASTM D6878/D6878M, sheet contains reinforcing fabrics or scrims.
    - a. Thickness: 80 mil, 0.080 inch (2.0 mm), nominal.
    - b. Thickness over Scrim: ASTM D7636, 0.034 typical
    - c. Breaking Strength: ASTM D751 350lbf minimum, 425lbf typical
    - d. Elongation Break of Reinforcement: ASTM D751 - 15% minimum, 25% typical
    - e. Tearing Strength: ASTM D751 - 55lbf minimum, 130lbf typical
    - f. Brittleness Point: ASTM D2137, -40F max, -50F typical
    - g. Linear Dimensional Change: ASTM D1204, 6hr at 158F - +/-1% max, -0.2% typical
    - h. Puncture Resistance: FTM 101C, method 2031: 400lbf min, 450lbf typical
  - 3. Color: To be selected from manufacturer's standard colors.
- B. Seaming Materials: As recommended by membrane manufacturer.
- C. Membrane Fasteners: As recommended and approved by membrane manufacturer.
- D. Formable Flashing: Non-reinforced, flexible, heat weldable, sheet, composed of thermoplastic polyolefin polymer and ethylene-propylene rubber
  - 1. Thickness: as required by roofing manufacturer
  - 2. Bonding adhesive: as required by roofing manufacturer
  - 3. Pourable sealer: two-part polyurethane, two-color for reliable mixing; pourable sealer by the membrane manufacturer
  - 4. Seam plates: as required by the roofing manufacturer
  - 5. Termination bars: Aluminum bars with integral caulk ledge; 1.3" wide by 0.10 inch thick
  - 6. Cut edge sealant: Synthetic rubber based, for use where the membrane reinforcement is exposed
  - 7. Coated Metal Flashing and Edgings: Galvanized steel with roofing manufacturer's bonded TPO coating
  - 8. Molded Flashing Accessories: Unreinforced TPO membrane pre-molded to suite a variety of flashing details, including pipe boots, inside corners, outside corners, etc
  - 9. Water Block Seal: butyl rubber sealant for use between two surfaces, not exposed to UV
- E. Flexible Flashing Material: Same material as membrane.

### 2.03 COVER BOARDS

- A. Cover Boards: Glass-mat faced gypsum panels complying with ASTM C1177/C1177M.
  - 1. Thickness: 1/4 inch (6.4 mm), fire-resistant.
  - 2. Products:
    - a. Georgia-Pacific; DensDeck Prime with EONIC Technology:  
[www.densdeck.com/#sle](http://www.densdeck.com/#sle).
    - b. Substitutions: See Section 016000 - Product Requirements.
- B. Cover Board: Faced and with high compressive strength polyisocyanurate (ISO) insulation complying with ASTM C1289 and the following characteristics:
  - 1. Grade and Compressive Strength: Grade 1, 109psi
  - 2. Board Size: 48x48 inches
  - 3. Board Thickness: 1/2 inch minimum

### 2.04 INSULATION

- A. Polyisocyanurate Board Insulation: Rigid cellular foam, complying with Federal Specification HH-I-1972/2, ASTM D1621, ASTM C1289, C350, D1622 and E84. Type II, Class 1, cellulose felt or glass fiber mat both faces: Grade 2 and with the following characteristics
  - 1. Compressive Strength: 20psi
  - 2. Board Size: Tapered insulation 4'x4', flatstock insulation 4'x8'
  - 3. Thickness: varies
- B. Polyisocyanurate Board Insulation: Rigid cellular foam, complying with ASTM C1289, Type II, Class 1, cellulose felt or glass fiber mat both faces; Grade 1 and with the following

characteristics:

1. Thermal Resistance: R-value of 5.41 Long Term Thermal Resistance (LTTR).

## **2.05 ACCESSORIES**

- A. Insulation Fasteners: Appropriate for purpose intended and approved by roofing manufacturer.
  1. Length as required for thickness of insulation material and penetration of deck substrate with insulation plates.
- B. Membrane Adhesive: As recommended by membrane manufacturer.
- C. Surface Conditioner for Adhesives: Compatible with membrane and adhesives.
- D. Thinners and Cleaners: As recommended by adhesive manufacturer, compatible with membrane.
- E. Insulation Adhesive: As recommended by insulation manufacturer.
- F. Roofing Nails: Galvanized, hot-dipped type, size and configuration as required to suit application.
- G. Fasteners for Steel Deck (for insulation application): Galvanized steel, flouropolymer-coated steel, or nonferrous metal screws recommended by manufacturer for material to be fastened and substrate and complying with requirements of governing authorities and listing agencies.
  1. Metal Deck: 3/4" minimum penetration of bottom of metal deck/panel
- H. Sealants: As recommended by membrane manufacturer.

## **PART 3 EXECUTION**

### **3.01 EXAMINATION**

- A. Verify that surfaces and site conditions are ready to receive work.
- B. Verify deck is supported and secure.
- C. Verify deck is clean and smooth, flat, free of depressions, waves, or projections, properly sloped and suitable for installation of roof system.
- D. Verify deck surfaces are dry and free of snow or ice.
- E. Verify that roof openings, curbs, and penetrations through roof are solidly set, and cant strips are in place.

### **3.02 INSTALLATION, GENERAL**

- A. Perform work in accordance with manufacturer's instructions, NRCA (RM), and NRCA (WM) applicable requirements.
- B. Do not apply roofing membrane during cold or wet weather conditions.
- C. Do not apply roofing membrane when ambient temperature is outside the temperature range recommended by manufacturer.
- D. Do not apply roofing membrane to damp or frozen deck surface or when precipitation is expected or occurring.
- E. Do not expose materials vulnerable to water or sun damage in quantities greater than can be weatherproofed the same day.

### **3.03 INSTALLATION - INSULATION, UNDER MEMBRANE**

- A. Attachment of Insulation:
  1. Mechanically fasten insulation to deck in accordance with roofing manufacturer's instructions and FM DS 1-28 Factory Mutual requirements.
- B. Cover Boards: Mechanically fasten cover boards in accordance with roofing manufacturer's instructions and FM (AG) Factory Mutual requirements.
- C. Lay subsequent layers of insulation with joints staggered minimum 6 inches (152 mm) from joints of preceding layer.
- D. Lay boards with edges in moderate contact without forcing. Cut insulation to fit neatly to perimeter blocking and around penetrations through roof.

- E. Do not install more insulation than can be covered with membrane in same day.

### 3.04 INSTALLATION - MEMBRANE

- A. Roll out membrane, free from wrinkles or tears. Place sheet into place without stretching.

- B. ~~Shingle joints on sloped substrate in direction of drainage.~~

- C. Overlap edges and ends and seal seams by contact tape, minimum 3 inches (76 mm). Seal permanently waterproof. Apply uniform bead of sealant to joint edge.

- D. Mechanical Attachment: Install membrane and mechanical attachment devices in accordance with manufacturer's instructions.

- E. At intersections with vertical surfaces:

1. Extend membrane over cant strips and up a minimum of 4 inches (102 mm) onto vertical surfaces.

2. Secure flashing to nailing strips at 4 inches (102 mm) on center.

- F. Around roof penetrations, seal flanges and flashings with flexible flashing.

- G. Coordinate installation of roof gutters downspouts and related flashings.

### 3.05 FIELD QUALITY CONTROL

- A. Provide daily on-site attendance of roofing and insulation manufacturer's representative during installation of this work.

### 3.06 CLEANING

- A. Remove bituminous markings from finished surfaces.

- B. In areas where finished surfaces are soiled by work of this section, consult manufacturer of surfaces for cleaning advice and comply with their documented instructions.

- C. Repair or replace defaced or damaged finishes caused by work of this section.

### 3.07 PROTECTION

- A. Protect installed roofing and flashings from construction operations.

- B. Where traffic must continue over finished roof membrane, protect surfaces using durable materials.

**END OF SECTION**

**SECTION 076200  
SHEET METAL FLASHING AND TRIM**

**PART 1 GENERAL**

**1.01 SECTION INCLUDES**

- A. Fabricated sheet metal items, including flashings, counterflashings, gutters, downspouts, fascia, soffit, , and other items indicated in Schedule.
- B. Sealants for joints within sheet metal fabrications.

**1.02 RELATED REQUIREMENTS**

- A. Section 042000 - Unit Masonry: Metal flashings embedded in masonry.
- B. Section 061000 - Rough Carpentry: Wood nailers for sheet metal work.
- C. Section 06 1000 - Rough Carpentry: Wood nailers, curbs for roofing, and items installed on the roof.
- D. Section 077100 - Roof Specialties:
- E. Section 079200 - Joint Sealants:

**1.03 REFERENCE STANDARDS**

- A. AAMA 2604 - Voluntary Specification, Performance Requirements and Test Procedures for High Performance Organic Coatings on Aluminum Extrusions and Panels (with Coil Coating Appendix); 2022.
- B. ASTM A 167 - Standard Specification for Stainless and Heat-Resisting Chromium-Nickel Steel Plate, Sheet, and Strip; 1999 (Reapproved 2004).
- C. ASTM A666 - Standard Specification for Annealed or Cold-Worked Austenitic Stainless Steel Sheet, Strip, Plate, and Flat Bar; 2023.
- D. ASTM A 792/A 792M - Standard Specification for Steel Sheet, 55% Aluminum-Zinc Alloy-Coated by the Hot-Dip Process; 2006a.
- E. ASTM B32 - Standard Specification for Solder Metal; 2020.
- F. SMACNA (ASMM) - Architectural Sheet Metal Manual; 2012.
- G. ANSI/SPRI ES-1, 2011. Wind Design Standard for Edge Systems Used with Low Slope Roofing Systems;.

**1.04 SUBMITTALS**

- A. See Section 013000 - Administrative Requirements, for submittal procedures.
- B. Shop Drawings: Indicate material profile, jointing pattern, jointing details, fastening methods, flashings, terminations, and installation details.
  - 1. Provide shop drawings for those items factory or shop fabricated, showing extent of the work and all required details to describe the installation.
- C. Provide samples for those items shop fabricated or assembled including all accessories and anchors required for the coping, fascia, curb or other sheet metal items. Submit samples of entire assembly to Architect for review and approval prior to commencing shop fabrication. Submit samples with actual finish to be installed. Samples to be eighteen inches long minimum.
- D. Provide manufacturer's guarantee on the applied finishes to the various prefinished sheet metal components against oxidation, checking, peeling, fading, chalking in excess of 8 (ASTM D 523), or other deterioration of the finish for a period of five years.
- E. Edge Metal Flashings-Submit certification that edge metal is fabricated, installed and tested in compliance with ANSI/SPRI ES-1, 2011.

**1.05 QUALITY ASSURANCE**

- A. Perform work in accordance with SMACNA (ASMM) and CDA A4050 requirements and standard details, except as otherwise indicated.

- B. Fabricator and Installer Qualifications: Company specializing in sheet metal work with 5 years of documented experience.

## **1.06 DELIVERY, STORAGE, AND HANDLING**

- A. Stack material to prevent twisting, bending, and abrasion, and to provide ventilation. Slope metal sheets to ensure drainage.
- B. Prevent contact with materials that could cause discoloration or staining.

## **PART 2 PRODUCTS**

### **2.01 SHEET MATERIALS**

- A. Galvanized Steel: ASTM A-653/A 653M, with G-90/Z275, commercial quality, or G-90 (ASTM A653/A 653M), lock-forming quality, hot-dip galvanized, mill phosphatized where indicated for painting; not less than 20 gauge 0.0359 inch thick, unless otherwise indicated.
- B. Aluminum-Zinc Coated Steel Sheet (AZ): ASTM A 792, Class AZ-50 coating, Grade 40, 55% aluminum, 1.6% silicon, 44.4% zinc, 20 gauge (0.0320 inch), unless noted otherwise; ASTM A 792/A 792M, Class AZ-150 coating, Grade 275 triple spot coat average equivalent to 0.80 mils thickness both sides.
- C. Aluminum or Steel Finishes: Comply with NAAMM "Metal Finishes Manual" to produce uniformly finished products. For colored finishes (prefinished), if any, provide coating as indicated and colors as selected by Architect from manufacturer's standard colors.
  - 1. Fluoropolymer Coating (FP): Manufacturer's standard two-coat, thermocured, full-strength 70 percent "Kynar 500" coating consisting of a primer and a minimum dry film thickness of 0.9 mil and 30 percent reflective gloss when tested in accordance with ASTM D 523.
  - 2. Durability: Provide coating that has been field tested under normal range of weathering conditions for minimum of 20 years without significant peel, blister, flake, chip, crack, or check in finish; in accordance with AAMA 2604.
    - a. Color and Gloss: As selected by Architect from Manufacturer's standard colors.
- D. Stainless Steel Sheet: ASTM A 167, ASTM A 666, Type 304, soft annealed, with No. 2D finish, except where harder temper is required for forming or performance; minimum 0.0187 inch thick, unless otherwise indicated.

### **2.02 ACCESSORIES**

- A. Fasteners: Noncorrosive metal, with soft EPDM washers. Match finish of exposed heads with material being fastened.
- B. Sealant: Type Elastomeric specified in Section 079200.
- C. Mastic Sealant: Polyisobutylene, nonhardening, nonskinning, nondrying, nonmigrating sealant.
- D. Epoxy Seam Sealer: 2-part, noncorrosive, aluminum seam-cementing compound.
- E. Adhesive: Type recommended for waterproof and weather-resistant seaming and adhesive.
- F. Clip Straps, Anchoring Devices and Similar Accessories: Compatible with material being installed.

### **2.03 FABRICATION**

- A. Fabricate sheet metal flashing and trim to comply with recommendations of SMACNA's "Architectural Sheet Metal Manual" that apply to the design, dimensions, metal and other characteristics of the item indicated.
- B. Fabricate sheet metal flashing and trim to comply with recommendations of ANSI/SPRI ES-1 that apply to the design, dimensions, metal and other characteristics of the item indicated.
- C. Form sections true to shape, accurate in size, square, and free from distortion or defects.
- D. Form pieces in longest possible lengths.
- E. Hem exposed edges on underside 1/2 inch (13 mm); miter and seam corners.
- F. Form material with batten seams, except where otherwise indicated. At moving joints, use sealed lapped, bayonet-type or interlocking hooked seams.



- G. Fabricate corners from one piece with minimum 18 inch (450 mm) long legs; seam for rigidity, seal with sealant.
- H. Fabricate vertical faces with bottom edge formed outward 1/4 inch (6 mm) and hemmed to form drip.
- I. Fabricate vertical faces with bottom edge formed outward 1/4 inch (6 mm) and hemmed to form drip.
- J. Fabricate flashings to allow toe to extend 2 inches (50 mm) over roofing gravel. Return and brake edges.
- K. Fabricate fascia and coping to profiles and coping to profiles and details shown herein and/or as indicated on the drawings. Fabrication to be free of face distortion and oil canning. Fabrication shall not mar the prefinished surfaces of exposed components. Shop form materials in their entirety with only length adjustments and attachments in the field.
  - 1. Contractor's Option: In lieu of shop fabricated fascia, copings and gutter and downspouts as herein identified, provide manufacturer's prefabricated fascia, coping and gutter and downspouts systems produced by:
    - a. W.P. Hickman Company.
    - b. Metal - Era
    - c. When required by roofing material manufacturer to procure "Manufacturer's Warranty", provide required fascia and coping systems as specified by roofing material manufacturer.
- L. Coat back-side of fabricated sheet metal with 15-mil sulfur-free bituminous coating, ASTM D 4479 Type 1, where required for water-tight construction provide hooked flanges filled with polyisobutylene mastic for 1-inch embedment or flanges. Space joints at intervals of not more than 50 feet for steel, 30 feet for zinc alloy or aluminum. Conceal expansion provisions where possible.
- M. 4 inch wide flange for setting sheet metal on MBR, and flexible sheet roofing system with concealment by MBR roofing sheet stripping or elastic roofing sheet stripping.

## **2.04 GUTTER AND DOWNSPOUT FABRICATION**

- A. Gutter: Profile as indicate
- B. Downspouts: Rectangular profile.
- C. Gutter and Downspouts: Size for rainfall intensity determined by a storm occurrence of 1 in 100 years in accordance with SMACNA (ASMM).
- D. Accessories: Profiled to suit gutters and downspouts.
  - 1. Anchorage Devices: In accordance with SMACNA (ASMM) requirements.
  - 2. Gutter Supports: Brackets.
  - 3. Downspout Supports: Straps.
- E. Splash Pads: Precast concrete type, of size and profiles indicated; minimum 3000 psi (21 MPa) at 28 days, with minimum 5 percent air entrainment.
- F. Downspout Boots: Steel.
  - 1. Manufacturer: Downspout Boots; [www.downspoutboots.com](http://www.downspoutboots.com)
- G. Downspout Extenders: Same material and finish as downspouts.

## **PART 3 EXECUTION**

### **3.01 EXAMINATION**

- A. Verify roof openings, curbs, pipes, sleeves, ducts, and vents through roof are solidly set, reglets in place, and nailing strips located.
- B. Verify roofing termination and base flashings are in place, sealed, and secure.

### **3.02 PREPARATION**

- A. Install starter and edge strips, and cleats before starting installation.

- B. Install surface mounted receivers where indicated true to lines and levels. Seal top of reglets with sealant.
- C. Back paint concealed metal surfaces with protective backing paint to a minimum dry film thickness of 15 mil (0.4 mm).

### 3.03 INSTALLATION

- A. Comply with manufacturer's instructions and SMACNA's "Architectural Sheet Metal Manual" allow for thermal expansion; set true to line and level as indicated. Install Work with laps, joints, and seams permanently watertight and weatherproof; conceal fasteners where possible. Corners and bends of prefinished materials to be of radius from the base metals. Refinish or regalvanize after fabrication.
  - 1. Coordinate handling and installation of joints and sheet metal materials, to minimize exposure of expansion, to damage from other work of other trades and to provide proper integration of units with membranes and flashings.
  - 2. Expansion Provisions: Provide for thermal expansion of exposed sheet metal Work. Space movement joints at maximum of 10 feet (3 m) with no joints allowed within 24 inches (610 mm) of corner or intersection. Where lapped or bayonet-type expansion provisions in Work cannot be used or would not be sufficiently weatherproof and waterproof, form expansion joints of intermeshing hooked flanges, not less than 1 inch (25 mm) deep, filled with mastic sealant (concealed within joints).
- B. Anchor work in place with noncorrosive fasteners, adhesives, setting compounds, tapes and other materials and devices as recommended by manufactures of each material or system. Provide for thermal expansion and building movements. Comply with recommendations of "Architectural Sheet Metal Manual" by SMACNA.
- C. Soldered Joints: Clean surfaces to be soldered, removing oils and foreign matter. Pretin edges of sheets to be soldered to a width of 1-1/2 inches (38 mm), except where pretinned surface would show in finished Work.
  - 1. Pretinning is not required for lead.
  - 2. Do not solder aluminum.
- D. Seal moving joints in metal work with elastomeric joint sealants, complying with requirements specified in Division 7 Section "Joint Sealant".
- E. Sealed Joints: Form nonexpansion, but movable, joints in metal to accommodate elastomeric sealant to comply with SMACNA standards. Fill joint with sealant and form metal to completely conceal sealant.
- F. Clean metal surfaces of other substances which could cause corrosion of metal or discoloring of finish.
- G. Seams: Fabricate nonmoving seams in sheet metal with flat-lock seams. Tin edges to be seamed, form seams, and solder.
- H. Seams: Fabricate nonmoving seams in aluminum with flat-lock seams. Form seams and seal with epoxy seam sealer. Rivet joints for additional strength.
- I. Separations: Separate noncompatible metals or corrosive substrates with a coating of asphalt mastic. 15-mil sulfur-free bituminous coating ASTM D 4479 Type 1 metals from corrosive substrates, including cementitious materials, wood or other absorbent materials or other permanent separation as recommended by manufacturer.
- J. Secure flashings in place using concealed fasteners, and use exposed fasteners only where permitted..
- K. Apply plastic cement compound between metal flashings and felt flashings.
- L. Fit flashings tight in place; make corners square, surfaces true and straight in planes, and lines accurate to profiles.
- M. Connect downspouts to downspout boots, and grout connection watertight.
- N. See details appended to the end of this section.

**3.04 FIELD QUALITY CONTROL**

- A. See Section 014000 - Quality Requirements, for field inspection requirements.
- B. Inspection will involve surveillance of work during installation to ascertain compliance with specified requirements.

**3.05 MARTIN RILEY FASCIA SYSTEM COMPONENTS**

**END OF SECTION**

# METAL FASCIA

Martin Riley architects/engineers FASCIA SYSTEM COMPONENTS

FABRICATE SHEET METAL FOR STANDARD FASCIA SYSTEM AND FASCIA EXTENDERS AS SHOWN BELOW ON THIS SHEET AND IN COMPLAINE WITH ANSI/SPRI ES-1 CURRENT EDITION. SHOP FABRICATE FASCIA AND EXTENDERS USING GAUGES AND FINISHES INDICATED AND SPECIFIED. ALL BENDS TO BE 3T U.N.O. AND STANDARD LENGTH 120 INCHES U.N.O. LAYOUT RUNS TO PRODUCE CUTS OF EQUAL LENGTH AT EACH END AND NO LESS THAN 60 INCHES MINIMUM. BUTT SECTIONS AND GAP 1/8" MINIMUM. PROVIDE CONCEALED SPLICE PLATES TO MATCH PROFILE BEHIND FASCIA AND EXTENDER OF 0.019 INCH ALUMINUM X 4 INCH WIDE. ANCHOR HOLES TO BE SLOTTED 1/8 INCH X 1/4 INCH U.N.O. AND AT 12 INCHES ON CENTER.

## RECOMMENDED MINIMUM GAUGES FOR FASCIA, COPING AND CLEATS SHOWN BELOW

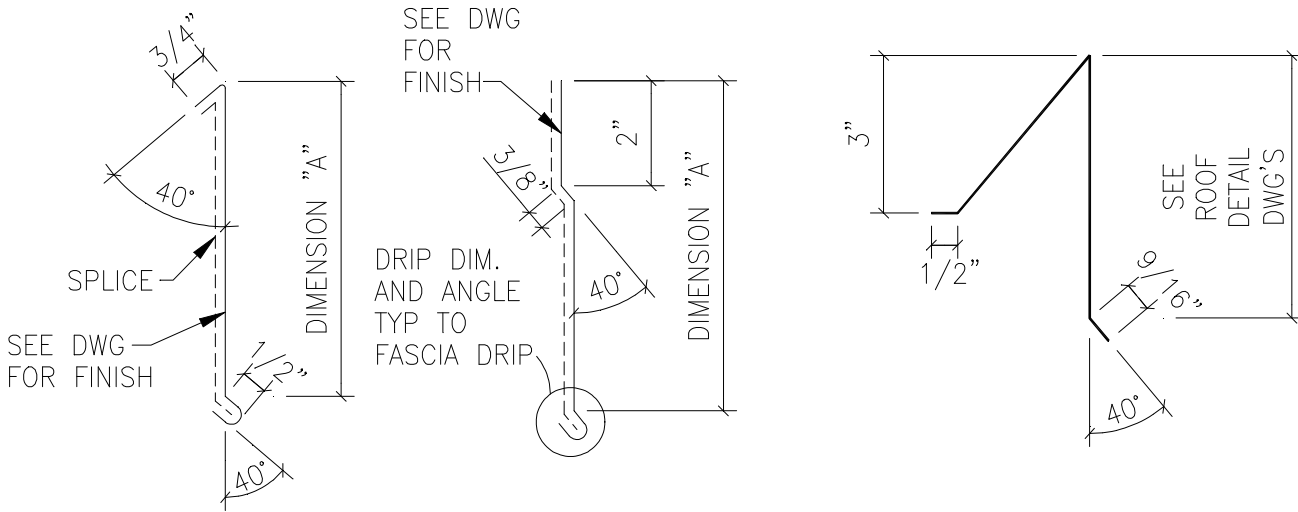

FASCIA

FASCIA EXTENDER

FASCIA CLIP

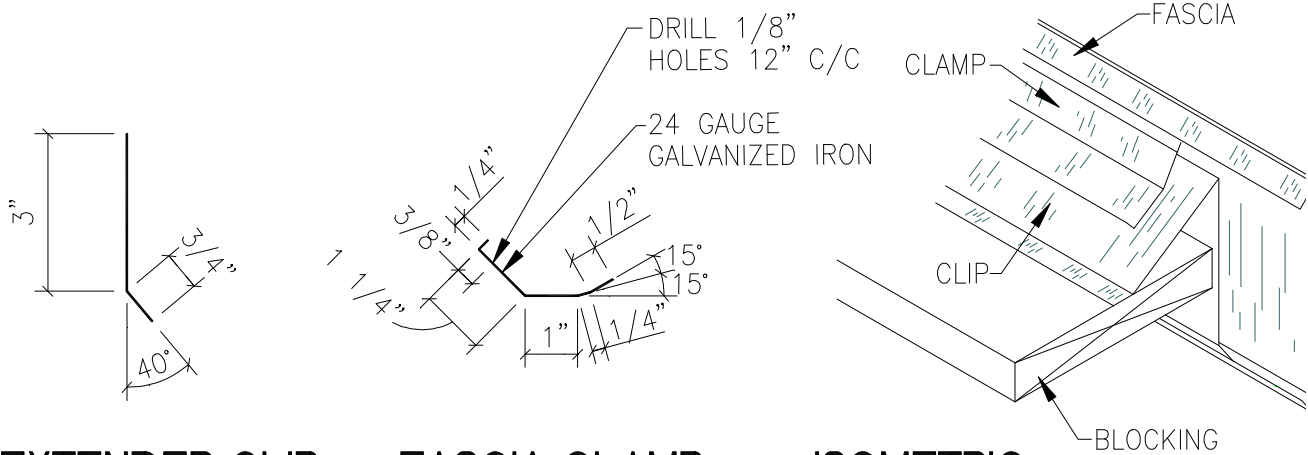

EXTENDER CLIP

FASCIA CLAMP

ISOMETRIC

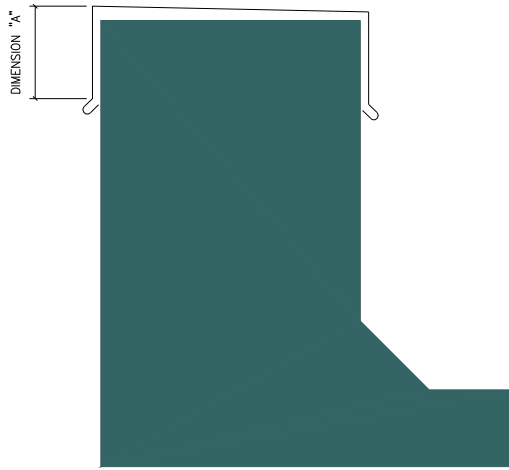

COPING

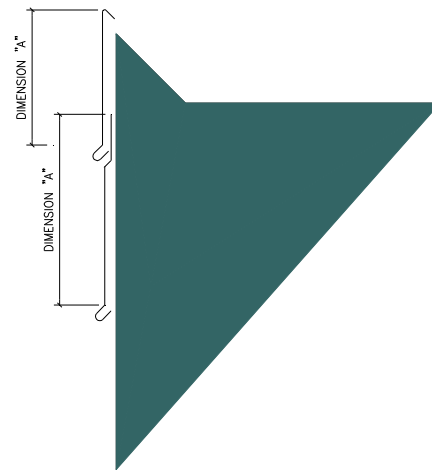

FASCIA AND EXTENDER

Exposed Face	Galvanized Steel	Cold Rolled Copper	Formed Aluminum	Stainless Steel	Cleat
Up to 4" (to 100 mm)	24 ga. (0.028" 0.7mm)	16 oz (0.022" 0.6mm)	0.040" (1.0 mm)	26 ga (0.016" 0.4mm)	One gauge heavier than fascia metal
> 4"-8" (>100-200mm)	24 ga. (0.028" 0.7mm)	16 oz (0.022" 0.6mm)	0.050" (1.3 mm)	26ga (0.016" 0.4mm)	One gauge heavier than fascia metal
>8"-10" (>200-250 mm)	22 ga (0.034" 0.9 mm)	20 oz (0.027" 0.7 mm)	0.063" (1.6mm)	24 ga (0.023" 0.6mm)	One gauge heavier than fascia metal
>10"-16" (>250-400 mm)	20 ga (0.040" 1.0mm)	20oz w/stiffening ribs	0.080" (2.0 mm)	22 ga (0.029" 0.7mm)	One gauge heavier than fascia metal

NOTES:

1. WHEN USING THE ABOVE MINIMUM THICKNESS GUIDELINES, OTHER ITEMS SHOULD BE CONSIDERED, SUCH AS FASTENING PATTERNS AND UNANCHORED OR UNSUPPORTED SPANS. HEAVIER THICKNESSES MAY BE REQUIRED. COMPLY WITH ANSI/SPRI ES-1 CURRENT EDITION PROVIDE CERTIFICATION UPON COMPLETION
2. ALL CLEATS SHALL BE CONTINUOUS WITH LENGTHS NOT TO EXCEED 12'-0" LONG. ALLOW A 1/4" GAP BETWEEN PIECES. STAGGER JOINTS IN CLEATS AND JOINTS IN FASCIA METAL.
3. LESSER GAUGES MAY BE INSTALLED @ LENGTHS LONGER THAN 8" WITH STIFFENER BEAD, ONLY IF INDICATED ON DRAWINGS

END OF SECTION 07 6200

## **SECTION 077100 ROOF SPECIALTIES**

### **PART 1 GENERAL**

#### **1.01 SECTION INCLUDES**

- A. Manufactured roof specialties, including copings, fascias, and gravel stops.
- B. Walkpads
- C. Roof Hatch
- D. Roof Hatch Safety Railing

#### **1.02 RELATED REQUIREMENTS**

- A. Section 077200 - Roof Accessories: Manufactured curbs, roof hatches, and snow guards.
- B. Section 079200 - Joint Sealers.

#### **1.03 REFERENCE STANDARDS**

- A. ANSI/SPRI/FM 4435/ES-1 - Test Standard for Edge Systems Used with Low Slope Roofing Systems; 2022.
- B. ASTM A 123/A 123M - Standard Specification for Zinc (Hot-Dip Galvanized) Coatings on Iron and Steel Products; 2002.
- C. ASTM A 653/A 653M - Standard Specification for Steel Sheet, Zinc-Coated (Galvanized) or Zinc-Iron Alloy-Coated (Galvannealed) by the Hot-Dip Process; 2007.
- D. ASTM B 209 - Standard Specification for Aluminum and Aluminum-Alloy Sheet and Plate; 2007.
- E. ASTM B 209M - Standard Specification for Aluminum and Aluminum-Alloy Sheet and Plate [Metric]; 2007.
- F. ASTM C 920 - Standard Specification for Elastomeric Joint Sealants; 2005.
- G. NRCA (RM) - The NRCA Roofing Manual; 2024.
- H. SMACNA (ASMM) - Architectural Sheet Metal Manual; 2012.

#### **1.04 SUBMITTALS**

- A. See Section 013000 - Administrative Requirements, for submittal procedures.
- B. Product Data: Provide data on shape of components, materials and finishes, anchor types and locations.
- C. Shop Drawings: Indicate configuration and dimension of components, adjacent construction, required clearances and tolerances, and other affected work. Include plans, elevations, sections and details. Provide shop drawings for factory or shop fabricated items including installation drawings.
- D. Shop Drawings: Indicate configuration and dimension of components, adjacent construction, required clearances and tolerances, and other affected work.
- E. Coordination Drawings: Roof plans drawn to scale and coordinating penetrations and roof-mounted items.
- F. Manufacturer's Installation Instructions: Indicate special procedures, fasteners, supporting members, and perimeter conditions requiring special attention.

### **PART 2 PRODUCTS**

#### **2.01 MATERIALS**

- A. Aluminum:
  - 1. Sheet: ASTM B 209 (ASTM B 209M) for alclad alloy 3005H25 or alloy and temper required to suit forming operations, with mill finish, unless otherwise indicated.
- B. Galvanized Steel Sheet:
  - 1. ASTM A 653/A 653M with G90 (Z275); commercial steel, unless otherwise indicated.

- a. Structural Quality: Grade 40 (Grade 275), where indicated or as required for strength.
- C. Fasteners:
  - 1. Same metal as metals being fastened, or nonmagnetic stainless steel or other noncorrosive metal as recommended by manufacturer. Match finish of exposed fasteners with finish of material being fastened.
- D. Gaskets:
  - 1. Manufacturer's standard tubular or fingered design of neoprene, EPDM, or PVC; or flat design of foam rubber, sponge neoprene, or cork.
- E. Elastomeric Sealant:
  - 1. Recommended by unit manufacturer that is compatible with joint surfaces; ASTM C 920, Type S, Grade NS, Class 25.

## 2.02 MANUFACTURERS

- A. Roof Edge Flashings and Copings:
  - 1. Metal-Era Inc: [www.metalera.com/#sle](http://www.metalera.com/#sle).
  - 2. Substitutions: See Section 016000 - Product Requirements.
- B. Walkway Pads:
  - 1. Carlisle Syntec Corporation
    - a. Sure-Seal interlocking Rubber Pavers
- C. Roof Hatch:
  - 1. The Bilco Company
  - 2. Safepro Roof Hatch
  - 3. Substitutions: See Section 01600 - Product Requirements.
- D. Roof Hatch Safety Railings:
  - 1. Safepro Roof Hatch Safety Rails

## 2.03 COMPONENTS

- A. Roof Edge Flashings: Factory fabricated to sizes required; corners mitered; concealed fasteners.
  - 1. Configuration: Fascia, cant, and edge securement for roof membrane.
  - 2. Pull-Off Resistance: Tested in accordance with ANSI/SPRI/FM 4435/ES-1 using test methods RE-1 and RE-2 to positive and negative design wind pressure as defined by applicable local building code.
  - 3. Material: Formed steel sheet, galvanized, 24 gauge, 0.024 inch (0.6 mm) thick, minimum.
  - 4. Finish: 70 percent polyvinylidene fluoride.
  - 5. Color: To be selected by Architect from manufacturer's standard range.
- B. Copings : Provide manufactures complete integral system with all accessories necessary to complete the installation including fasteners, clips, splice plates, welded inside and outside corners. Custom curve and face dimensions and as required.
- C. Walkway Pads:
  - 1. Provide 24 inch square by 2 inch thick rubber pavers with premolded "U" channels weighing 24 pounds per unit. Install whole units according to manufacturer's specification with adhesive attachment along the "U" channel as furnished by walkway pad manufacturer.
  - 2. Provide ramp tiles (if any) of the same material at transitions and as identified on the drawings.
- D. Roof Hatch
  - 1. Furnish and install where indicated on plans metal roof hatch Model SPH size 36" (width ) x 30" (length). Length denotes hinge side. The roof hatch shall be single leaf. The roof hatch shall be pre-assembled from the manufacturer.
  - 2. Performance characteristics:

- a. Cover(s) shall be reinforced to support a minimum live load of 40 psf with a maximum deflection of 1/150th of the span or 20 psf wind uplift.
- b. Operation of the cover shall be smooth and easy with controlled operation throughout the entire arc of the opening and closing.
- c. Operation of the cover shall not be affected by temperature.
- d. Entire hatch shall be weathertight with fully-welded corner joints on cover and curb.
- 3. Cover: Shall be 14 gauge (G90) galvanized steel with radius corners for safety and shall be fully-welded at the corners for watertight construction. Cover shall have a rubber gasket that is bonded to the cover interior to assure a continuous seal when compressed to the top surface of the curb.
- 4. Cover insulation: Shall be 1" thick polyisocyanurate with an R-value of 5.6 (New ASTM C1289-13e1), fully covered and protected by a 14 gauge (G90) steel liner.
- 5. Curb: Shall be 14 gauge (G90) galvanized steel with durable re-caotable gray primer finish. It shall be 12" in height with a 3-1/2" wide mounting flange with holes for roof attachment. The curb shall be equipped with an integral metal capflashing of the same gauge and material as the curb, fully-welded at the corners.
- 6. Curb insulation: Shall be 1" fiber board.
- 7. Lifting mechanisms: For smooth operation of the cover, provide compression springs encased in zinc-plated telescopic tubes. Furnish an automatic hold-open arm with vinyl grip. For safety and added security, latching shall include interior and exterior handles with provisions for an inside padlock.
- 8. Hardware:
  - a. Heavy pintle hinges shall be provided.
  - b. Cover(s) shall be equipped with a spring latch with interior and exterior turn handles.
  - c. Roof hatch shall be equipped with interior padlock hasps.
  - d. The latch strike shall be a welded component bolted to the curb assembly.
  - e. Cover shall automatically lock in the open position with an automatic hold-open arm with vinyl grip.
- 9. Finishes: Factory finish shall be Galvanized Steel with a re-coatable gray primer finish.
- E. Roof Hatch Safety Railings: Provide safety rails to fit existing hatch size. Rails shall be 1-1/2" OD 0.075 wall cold-rolled electric welded steel tubing. Rails shall be OSHA compliant, protecting workers from falling through roof hatch with self closing gate that functions as two additional ladder rungs. eliminating need for ladder safety post. Safety rail shall be powder coated safety yellow.
  - 1. Gravity self-closing gate with spring assist. Non-collapsible full wrap-around 1-1/2" tubing grab hold (welded - no fittings). Heavy duty hinges with 5/8" hinge pin with built-in pinch-less gate stop and pull up full open positioning. Wrap-around forward protruding stanchions. Hinges on left or right side.

## **PART 3 EXECUTION**

### **3.01 EXAMINATION**

- A. Verify that deck, curbs, roof membrane, base flashing, and other items affecting work of this Section are in place and positioned correctly.

### **3.02 INSTALLATION**

- A. Install components in accordance with manufacturer's instructions and NRCA (RM) applicable requirements.
- B. Coordinate installation of roof accessories with installation of roof deck, roof insulation, flashing, roofing membranes, penetrations, equipment, and other construction to ensure that combined elements are waterproof and weathertight. Anchor roof accessories securely to supporting structural substrates so they are capable of withstanding lateral and thermal stresses, and inward and outward loading pressures. Conform to SMACNA Architectural Sheet Metal Manual drawing details for fabricating units.
- C. NRCA's "Roofing and Waterproofing Manual" details for installing units.



- D. Coordinate installation of sealants and roofing cement with work of this section to ensure water tightness.
- E. Separation: Separate metal from incompatible metal or corrosive substrates, including wood, by coating concealed surfaces, at locations of contact, with bituminous coating or providing other permanent separation.
- F. Flange Seals: Unless otherwise indicated, set flanges of accessory units in a thick bed of roofing cement to form seal.
- G. Clean exposed surfaces according to manufacturer's written instructions. Touch up damaged metal coatings.

**END OF SECTION**

## **SECTION 078400 FIRESTOPPING**

### **PART 1 GENERAL**

#### **1.01 SECTION INCLUDES**

- A. Firestopping systems.
- B. Firestopping of joints and penetrations in fire-resistance-rated and smoke-resistant assemblies, whether indicated on drawings or not, and other openings indicated.

#### **1.02 RELATED REQUIREMENTS**

- A. Section 016116 - Volatile Organic Compound (VOC) Content Restrictions.
- B. See Life Safety Plans.

#### **1.03 REFERENCE STANDARDS**

- A. ASTM E119 - Standard Test Methods for Fire Tests of Building Construction and Materials; 2022.
- B. ASTM E814 - Standard Test Method for Fire Tests of Penetration Firestop Systems; 2023a.
- C. SCAQMD 1168 - Adhesive and Sealant Applications; 1989, with Amendment (2022).
- D. UL (FRD) - Fire Resistance Directory; Current Edition.

#### **1.04 SUBMITTALS**

- A. See Section 013000 - Administrative Requirements for submittal procedures.
- B. Schedule of Firestopping: List each type of penetration, perimeter and joint, fire rating of the assembly, and firestopping test or design number.
- C. Product Data: Provide data on product characteristics.
- D. Submit material safety data sheets (MSDS) for product used on the project.
- E. Manufacturer's Installation Instructions: Indicate preparation and installation instructions.
- F. Manufacturer's Certificate: Certify that products meet or exceed specified requirements.
- G. Manufacturer's qualification statement.
- H. Manufacturer's engineering judgment identification number and document details when no qualified tested system is available for an application. Engineering judgment must include both project name and contractor's name who will install firestop system as described in document.
- I. Contractor to submit FM 4991 or UL Accredited Certificate from qualified installer.
- J. Manufacturer to provide and contractor to submit firestop training letter.

#### **1.05 QUALITY ASSURANCE**

- A. Fire Testing: Provide firestopping assemblies of designs that provide the scheduled fire ratings when tested in accordance with methods indicated.
  - 1. Listing in UL (FRD), FM (AG), or ITS (DIR) will be considered as constituting an acceptable test report.
- B. Engineering Judgment: For those firestop applications that exist for which no qualified tested system is available through a manufacturer, an engineering judgment derived from similar qualified tested system designs or other tests will be submitted to local authorities having jurisdiction for their review and approval prior to installation. Engineering judgment documents must follow requirements set forth by the International Firestop Council.
- C. Manufacturer Qualifications: Company specializing in manufacturing the products specified in this section with minimum three years documented experience.
- D. Installer Qualifications: Company specializing in performing the work of this section and:
  - 1. UL Approved Contractor
  - 2. Approved by Factory Mutual Research Corporation under FM 4991.
  - 3. Verification of minimum three years documented experience installing work of this type.

4. Verification of at least five satisfactorily completed projects of comparable size and type.
5. Licensed by local authorities having jurisdiction (AHJ).

#### **1.06 FIELD CONDITIONS**

- A. Comply with firestopping manufacturer's recommendations for temperature and conditions during and after installation. Maintain minimum temperature before, during, and for recommended number of days after installation of materials.
- B. Provide ventilation in areas where solvent-cured materials are being installed.

### **PART 2 PRODUCTS**

#### **2.01 MATERIALS**

- A. Primers, Sleeves, Forms, Insulation, Packing, Stuffing, and Accessories: Provide type of materials as required for tested firestopping assembly.

#### **2.02 FIRESTOPPING SYSTEMS**

- A. Firestopping at Uninsulated Metallic Pipe and Conduit Penetrations, of diameter 4 inches (100 mm) or less: Any material meeting requirements.
  1. Floors: UL Design, F Rating 2 hour.
  2. Stairway Walls: UL Design, F Rating 2 hour.
  3. Corridor Walls: UL Design, F Rating 1-1/2 hour.
  4. Other Interior Partitions: UL Design, F Rating 3/4 hour.
- B. Firestopping at Combustible Pipe and Conduit Penetrations, of diameter 4 inches (100 mm) or less: Any material meeting requirements.
  1. Floors: UL Design, F Rating 2 hour.
  2. Stairway Walls: UL Design, F Rating 2 hour.
  3. Corridor Walls: UL Design, F Rating 1-1/2 hour.
  4. Other Interior Partitions: UL Design, F Rating 3/4 hour.
- C. Firestopping at Uninsulated Metallic Pipe and Conduit Penetrations, of diameter 4 inches (100 mm) or less: Any material meeting requirements.
  1. Floors: UL Design, F Rating 2 hour.
  2. Stairway Walls: UL Design, F Rating 2 hour.
  3. Corridor Walls: UL Design, F Rating 1-1/2 hour.
  4. Other Interior Partitions: UL Design, F Rating 3/4 hour.
- D. Firestopping at Cable Penetrations, not in Conduit or Cable Tray: Any material meeting requirements.
  1. Floors: UL Design, F Rating 2 hour.
  2. Stairway Walls: UL Design, F Rating 2 hour.
  3. Corridor Walls: UL Design, F Rating 1-1/2 hour.
  4. Other Interior Partitions: UL Design, F Rating 3/4 hour.
- E. Firestopping at Control Joints (without Penetrations): Any material meeting requirements.
  1. Between Top of Fire-Rated Walls and Bottom of Slab Above: UL Design, F Rating 1-1/2 hour.
  2. Floors: UL Design, F Rating 2 hour.
  3. Stairway Walls: UL Design, F Rating 2 hour.
  4. Corridor Walls: UL Design, F Rating 1-1/2 hour.
  5. Other Interior Partitions: UL Design, F Rating 3/4 hour.

#### **2.03 MATERIALS**

- A. Firestopping Sealants: Provide only products having lower volatile organic compound (VOC) content than required by South Coast Air Quality Management District Rule No.1168.
- B. Elastomeric Silicone Firestopping: Single component silicone elastomeric compound and compatible silicone sealant; conforming to the following:
  1. Manufacturers:
    - a. A/DFire Protection Systems Inc: [www.adfire.com](http://www.adfire.com).

- b. 3M Fire Protection Products: [www.3m.com/firestop](http://www.3m.com/firestop).
  - c. Hilti, Inc: [www.us.hilti.com](http://www.us.hilti.com).
  - d. Specified Technologies, Inc: [www.stifirestop.com](http://www.stifirestop.com).
  - e. Substitutions: See Section 01 6000 - Product Requirements.
- C. Foam Firestopping: Single component silicone foam compound; conforming to the following:
- 1. Manufacturers:
    - a. 3M Fire Protection Products: [www.3m.com/firestop](http://www.3m.com/firestop).
    - b. Hilti, Inc: [www.us.hilti.com](http://www.us.hilti.com).
    - c. Specified Technologies, Inc: [www.stifirestop.com](http://www.stifirestop.com).
    - d. Substitutions: See Section 01 6000 - Product Requirements.
- D. Fibered Compound Firestopping: Formulated compound mixed with incombustible non-asbestos fibers; conforming to the following:
- 1. Manufacturers:
    - a. A/DFire Protection Systems Inc: [www.adfire.com](http://www.adfire.com).
    - b. USG: [www.usg.com](http://www.usg.com).
    - c. Substitutions: See Section 01 6000 - Product Requirements.
- E. Fiber Firestopping: Mineral fiber insulation used in conjunction with elastomeric surface sealer forming airtight bond to opening; conforming to the following:
- 1. Manufacturers:
    - a. A/DFire Protection Systems Inc: [www.adfire.com](http://www.adfire.com).
    - b. Pecora Corporation: [www.pecora.com](http://www.pecora.com).
    - c. Thermafiber, Inc: [www.thermafiber.com](http://www.thermafiber.com).
    - d. Substitutions: See Section 01 6000 - Product Requirements.
- F. Firestop Devices - Wrap Type: Mechanical device with incombustible filler and collar, intended to be installed after penetrating item has been installed; conforming to the following:
- 1. Manufacturers:
    - a. RectorSeal: [www.rectorseal.com](http://www.rectorseal.com).
    - b. 3M Fire Protection Products: [www.3m.com/firestop](http://www.3m.com/firestop).
    - c. Hilti, Inc: [www.us.hilti.com](http://www.us.hilti.com).
    - d. Specified Technologies, Inc: [www.stifirestop.com](http://www.stifirestop.com).
    - e. Substitutions: See Section 01 6000 - Product Requirements.
- G. Firestop Devices - Cast-In Type: Sleeve and sealing material, intended to be cast in concrete floor forms or in concrete on metal deck, not requiring any additional materials to achieve penetration seal.
- 1. Manufacturers:
    - a. 3M Fire Protection Products: [www.3m.com/firestop](http://www.3m.com/firestop).
    - b. Hilti, Inc: [www.us.hilti.com](http://www.us.hilti.com).
    - c. Substitutions: See Section 01 6000 - Product Requirements.
- H. Intumescent Putty: Compound that expands on exposure to surface heat gain; conforming to the following:
- 1. Manufacturers:
    - a. RectorSeal: [www.rectorseal.com](http://www.rectorseal.com).
    - b. 3M Fire Protection Products: [www.3m.com/firestop](http://www.3m.com/firestop).
    - c. Hilti, Inc: [www.us.hilti.com](http://www.us.hilti.com).
    - d. Specified Technologies, Inc: [www.stifirestop.com](http://www.stifirestop.com).
    - e. Substitutions: See Section 01 6000 - Product Requirements.
- I. Reusable Firestopping: Removable intumescent compressible shapes, pillows, or blocks specifically tested in removable configuration; conforming to the following:
- 1. Manufacturers:
    - a. RectorSeal: [www.rectorseal.com](http://www.rectorseal.com).
    - b. Hilti, Inc: [www.us.hilti.com](http://www.us.hilti.com).
    - c. Nelson FireStop Products: [www.nelsonfirestop.com](http://www.nelsonfirestop.com).

- d. Specified Technologies, Inc: [www.stifirestop.com](http://www.stifirestop.com).
  - e. Substitutions: See Section 01 6000 - Product Requirements.
- J. Primers, Sleeves, Forms, Insulation, Packing, Stuffing, and Accessories: Type required for tested assembly design.

### **PART 3 EXECUTION**

#### **3.01 EXAMINATION**

- A. Verify openings are ready to receive the work of this section.

#### **3.02 PREPARATION**

- A. Clean substrate surfaces of dirt, dust, grease, oil, loose material, or other materials that could adversely affect bond of firestopping material.
- B. Remove incompatible materials that could adversely affect bond.
- C. Install backing materials to prevent liquid material from leakage.

#### **3.03 INSTALLATION**

- A. Install materials in manner described in fire test report and in accordance with manufacturer's instructions, completely closing openings.
- B. Do not cover installed firestopping until inspected by authorities having jurisdiction.
- C. Install labeling required by code.

#### **3.04 CLEANING**

- A. Clean adjacent surfaces of firestopping materials.

#### **3.05 PROTECTION**

- A. Protect adjacent surfaces from damage by material installation.

**END OF SECTION**

**SECTION 079200  
JOINT SEALANTS**

**PART 1 GENERAL**

**1.01 SECTION INCLUDES**

- A. Nonsag gunnable joint sealants.
- B. Joint backings and accessories.

**1.02 REFERENCE STANDARDS**

- A. ASTM C794 - Standard Test Method for Adhesion-in-Peel of Elastomeric Joint Sealants; 2018 (Reapproved 2022).
- B. ASTM C920 - Standard Specification for Elastomeric Joint Sealants; 2018.
- C. ASTM C1087 - Standard Test Method for Determining Compatibility of Liquid-Applied Sealants with Accessories Used in Structural Glazing Systems; 2023.
- D. ASTM C1193 - Standard Guide for Use of Joint Sealants; 2016 (Reapproved 2023).
- E. ASTM C1311 - Standard Specification for Solvent Release Sealants; 2022.

**1.03 SUBMITTALS**

- A. See Section 013000 - Administrative Requirements for submittal procedures.
- B. Product Data for Sealants: Submit manufacturer's technical data sheets for each product to be used, that includes the following.
  - 1. Physical characteristics, including movement capability, VOC content, hardness, cure time, and color availability.
  - 2. List of backing materials approved for use with the specific product.
  - 3. Substrates that product is known to satisfactorily adhere to and with which it is compatible.
  - 4. Substrates the product should not be used on.
  - 5. Substrates for which use of primer is required.
- C. Product Data for Accessory Products: Submit manufacturer's technical data sheet for each product to be used, including physical characteristics, installation instructions, and recommended tools.
- D. Color Cards for Selection: Where sealant color is not specified, submit manufacturer's color cards showing standard colors available for selection.
- E. Preconstruction Laboratory Test Reports: Submit at least four weeks prior to start of installation.
- F. Installation Log: Submit filled out log for each length or instance of sealant installed.

**1.04 QUALITY ASSURANCE**

- A. Manufacturer Qualifications: Company specializing in manufacturing the products specified in this section with minimum three years documented experience.
- B. Installer Qualifications: Company specializing in performing the work of this section and with at least three years of documented experience.
- C. Preconstruction Laboratory Testing: Arrange for sealant manufacturer(s) to test each combination of sealant, substrate, backing, and accessories.
  - 1. Adhesion Testing: In accordance with ASTM C794.
  - 2. Compatibility Testing: In accordance with ASTM C1087.
  - 3. Allow sufficient time for testing to avoid delaying the work.
  - 4. Deliver to manufacturer sufficient samples for testing.
  - 5. Report manufacturer's recommended corrective measures, if any, including primers or techniques not indicated in product data submittals.
  - 6. Testing is not required if sealant manufacturer provides data showing previous testing, not older than 24 months, that shows satisfactory adhesion, lack of staining, and compatibility.

## **1.05 WARRANTY**

- A. See Section 017800 - Closeout Submittals for additional warranty requirements.
- B. Correct defective work within a five year period after Date of Substantial Completion.
- C. Warranty: Include coverage for installed sealants and accessories that fail to achieve watertight seal , exhibit loss of adhesion or cohesion, or do not cure.

## **PART 2 PRODUCTS**

### **2.01 JOINT SEALANT APPLICATIONS**

- A. Scope:
  - 1. Exterior Joints: Seal open joints, whether or not the joint is indicated on drawings, unless specifically indicated not to be sealed. Exterior joints to be sealed include, but are not limited to, the following items.
    - a. Wall expansion and control joints.
    - b. Joints between door, window, and other frames and adjacent construction.
    - c. Joints between different exposed materials.
    - d. Openings below ledge angles in masonry.
    - e. Other joints indicated below.
  - 2. Do not seal the following types of joints.
    - a. Intentional weepholes in masonry.
    - b. Joints indicated to be treated with manufactured expansion joint cover or some other type of sealing device.
    - c. Joints where sealant is specified to be provided by manufacturer of product to be sealed.
    - d. Joints where installation of sealant is specified in another section.
    - e. Joints between suspended panel ceilings/grid and walls.

### **2.02 NONSAG JOINT SEALANTS**

- A. Polyurethane Sealant: ASTM C920, Grade NS, Uses M and A; single or multi-component; not expected to withstand continuous water immersion or traffic.
  - 1. Movement Capability: Plus and minus 50 percent, minimum.
  - 2. Color: To be selected by Architect from manufacturer's standard range.
- B. Non-Curing Butyl Sealant: Solvent-based; ASTM C1311; single component, non-sag, non-skinning, non-hardening, non-bleeding; non-vapor-permeable; intended for fully concealed applications.

### **2.03 ACCESSORIES**

- A. Backer Rod: Cylindrical cellular foam rod with surface that sealant will not adhere to, compatible with specific sealant used, and recommended by backing and sealant manufacturers for specific application.
  - 1. Closed Cell and Bi-Cellular: 25 to 33 percent larger in diameter than joint width.
- B. Backing Tape: Self-adhesive polyethylene tape with surface that sealant will not adhere to and recommended by tape and sealant manufacturers for specific application.
- C. Masking Tape: Self-adhesive, nonabsorbent, non-staining, removable without adhesive residue, and compatible with surfaces adjacent to joints and sealants.
- D. Joint Cleaner: Non-corrosive and non-staining type, type recommended by sealant manufacturer; compatible with joint forming materials.
- E. Primers: Type recommended by sealant manufacturer to suit application; non-staining.

## **PART 3 EXECUTION**

### **3.01 EXAMINATION**

- A. Verify that joints are ready to receive work.
- B. Verify that backing materials are compatible with sealants.

- C. Verify that backer rods are of the correct size.

### **3.02 PREPARATION**

- A. Remove loose materials and foreign matter that could impair adhesion of sealant.
- B. Clean joints, and prime as necessary, in accordance with manufacturer's instructions.
- C. Perform preparation in accordance with manufacturer's instructions and ASTM C1193.
- D. Mask elements and surfaces adjacent to joints from damage and disfigurement due to sealant work; be aware that sealant drips and smears may not be completely removable.

### **3.03 INSTALLATION**

- A. Perform work in accordance with sealant manufacturer's requirements for preparation of surfaces and material installation instructions.
- B. Perform installation in accordance with ASTM C1193.
- C. Install bond breaker backing tape where backer rod cannot be used.
- D. Install sealant free of air pockets, foreign embedded matter, ridges, and sags, and without getting sealant on adjacent surfaces.
- E. Do not install sealant when ambient temperature is outside manufacturer's recommended temperature range, or will be outside that range during the entire curing period, unless manufacturer's approval is obtained and instructions are followed.
- F. Nonsag Sealants: Tool surface concave, unless otherwise indicated; remove masking tape immediately after tooling sealant surface.

**END OF SECTION**



**SECTION 081113  
HOLLOW METAL DOORS AND FRAMES**

**PART 1 GENERAL**

**1.01 SECTION INCLUDES**

- A. Non-fire-rated hollow metal doors and frames.
- B. Hollow metal frames for wood doors.
- C. Fire-rated hollow metal doors and frames.
- D. Thermally insulated hollow metal doors with frames.
- E. Hollow metal borrowed lites glazing frames.

**1.02 RELATED REQUIREMENTS**

- A. Section 087100 - Door Hardware.
- B. Section 088000 - Glazing: Glass for doors and borrowed lites.
- C. Section 099123 - Interior Painting: Field painting.

**1.03 ABBREVIATIONS AND ACRONYMS**

- A. ANSI: American National Standards Institute.
- B. ASCE: American Society of Civil Engineers.
- C. HMMA: Hollow Metal Manufacturers Association.
- D. NAAMM: National Association of Architectural Metal Manufacturers.
- E. NFPA: National Fire Protection Association.
- F. SCIF: Sensitive Compartmented Information Facility.
- G. SDI: Steel Door Institute.
- H. UL: Underwriters Laboratories.

**1.04 REFERENCE STANDARDS**

- A. ADA Standards - 2010 ADA Standards for Accessible Design; 2010.
- B. ANSI/SDI A250.3 - Test Procedure and Acceptance Criteria for Factory Applied Finish Coatings for Steel Doors and Frames; 2019.
- C. ANSI/SDI A250.4 - Test Procedure and Acceptance Criteria for Physical Endurance for Steel Doors, Frames and Frame Anchors; 2022.
- D. ANSI/SDI A250.8 - Specifications for Standard Steel Doors and Frames (SDI-100); 2023.
- E. ANSI/SDI A250.10 - Test Procedure and Acceptance Criteria for Prime Painted Steel Surfaces for Steel Doors and Frames; 2020.
- F. ASTM A653/A653M - Standard Specification for Steel Sheet, Zinc-Coated (Galvanized) or Zinc-Iron Alloy-Coated (Galvannealed) by the Hot-Dip Process; 2023.
- G. ASTM A1008/A1008M - Standard Specification for Steel, Sheet, Cold-Rolled, Carbon, Structural, High-Strength Low-Alloy, High-Strength Low-Alloy with Improved Formability, Required Hardness, Solution Hardened, and Bake Hardenable; 2023.
- H. ASTM A1011/A1011M - Standard Specification for Steel, Sheet and Strip, Hot-Rolled, Carbon, Structural, High-Strength Low-Alloy, High-Strength Low-Alloy with Improved Formability, and Ultra-High Strength; 2023.
- I. ASTM C143/C143M - Standard Test Method for Slump of Hydraulic-Cement Concrete; 2020.
- J. ASTM C476 - Standard Specification for Grout for Masonry; 2023.
- K. ASTM E84 - Standard Test Method for Surface Burning Characteristics of Building Materials; 2023c.
- L. ICC A117.1 - Accessible and Usable Buildings and Facilities; 2017.

- M. ITS (DIR) - Directory of Listed Products; Current Edition.
- N. NAAMM HMMA 805 - Recommended Selection and Usage Guide for Hollow Metal Doors and Frames; 2012.
- O. NAAMM HMMA 830 - Hardware Selection for Hollow Metal Doors and Frames; 2002.
- P. NAAMM HMMA 831 - Hardware Locations for Hollow Metal Doors and Frames; 2011.
- Q. NAAMM HMMA 840 - Guide Specifications For Receipt, Storage and Installation of Hollow Metal Doors and Frames; 2017.
- R. NAAMM HMMA 850 - Fire-Rated Hollow Metal Doors and Frames; 2014.
- S. NAAMM HMMA 860 - Guide Specifications for Hollow Metal Doors and Frames; 2018.
- T. NFPA 80 - Standard for Fire Doors and Other Opening Protectives; 2022.
- U. NFPA 252 - Standard Methods of Fire Tests of Door Assemblies; 2022.
- V. UL (DIR) - Online Certifications Directory; Current Edition.
- W. UL 10C - Standard for Positive Pressure Fire Tests of Door Assemblies; Current Edition, Including All Revisions.

#### **1.05 SUBMITTALS**

- A. See Section 013000 - Administrative Requirements for submittal procedures.
- B. Product Data: Materials and details of design and construction, hardware locations, reinforcement type and locations, anchorage and fastening methods, and finishes; and one copy of referenced standards/guidelines.
- C. Shop Drawings: Details of each opening, showing elevations, glazing, frame profiles, and any indicated finish requirements.

#### **1.06 QUALITY ASSURANCE**

- A. Manufacturer Qualifications: Company specializing in manufacturing products specified in this section, with not less than three years documented experience.
- B. Installer Qualifications: Company specializing in performing work of the type specified and with at least three years of documented experience.
- C. Maintain at project site copies of reference standards relating to installation of products specified.

#### **1.07 DELIVERY, STORAGE, AND HANDLING**

- A. Comply with NAAMM HMMA 840 or ANSI/SDI A250.8 (SDI-100) in accordance with specified requirements.
- B. Protect with resilient packaging; avoid humidity build-up under coverings; prevent corrosion and adverse effects on factory applied painted finish.

### **PART 2 PRODUCTS**

#### **2.01 MANUFACTURERS**

- A. Hollow Metal Doors and Frames:
  1. Curries, an Assa Abloy Group company: [www.assaabloydss.com/#sle](http://www.assaabloydss.com/#sle).
  2. Republic Doors, an Allegion brand: [www.republicdoor.com/#sle](http://www.republicdoor.com/#sle).
  3. Steelcraft, an Allegion brand: [www.allegion.com/#sle](http://www.allegion.com/#sle).
  4. Technical Glass Products; SteelBuilt Window & Door Systems: [www.tgpamerica.com/#sle](http://www.tgpamerica.com/#sle).
  5. Substitutions: See Section 016000 - Product Requirements.

#### **2.02 PERFORMANCE REQUIREMENTS**

- A. Requirements for Hollow Metal Doors and Frames:
  1. Steel Sheet: Comply with one or more of the following requirements; galvanized steel complying with ASTM A653/A653M, cold-rolled steel complying with ASTM A1008/A1008M, or hot-rolled pickled and oiled (HRPO) steel complying with ASTM

- A1011/A1011M, commercial steel (CS) Type B, for each.
2. Accessibility: Comply with ICC A117.1 and ADA Standards.
  3. Exterior Door Top Closures: Flush end closure channel, with top and door faces aligned.
  4. Door Edge Profile: Manufacturers standard for application indicated.
  5. Typical Door Face Sheets: Flush.
- B. Combined Requirements: If a particular door and frame unit is indicated to comply with more than one type of requirement, comply with the specified requirements for each type; for instance, an exterior door that is also indicated as being sound-rated must comply with the requirements specified for exterior doors and for sound-rated doors; where two requirements conflict, comply with the most stringent.

## 2.03 HOLLOW METAL DOORS

- A. Exterior Doors: Thermally insulated.
1. Based on NAAMM HMMA Custom Guidelines:
    - a. Comply with guidelines of NAAMM HMMA 860 for Hollow Metal Doors and Frames.
    - b. Performance Level 3 - Heavy Duty, in accordance with NAAMM HMMA 805.
    - c. Physical Performance Level C, 250,000 cycles; in accordance with ANSI/SDI A250.4.
    - d. Door Face Metal Thickness: 18 gauge, 0.042 inch (1.0 mm), minimum.
  2. Door Core Material: Polyurethane, 1.8 lbs/cu ft minimum density.
    - a. Foam Plastic Insulation: Manufacturer's standard board insulation with maximum flame spread index (FSI) of 75, and maximum smoke developed index (SDI) of 450 in accordance with ASTM E84, and completely enclosed within interior of door.
  3. Door Thermal Resistance: R-Value of 8.7, minimum, for installed thickness of polyurethane.
  4. Door Thickness: 1-3/4 inches (44.5 mm), nominal.
  5. Top Closures for Outswinging Doors: Flush with top of faces and edges.
  6. Weatherstripping: Refer to Section 087100.
  7. Door Finish: Factory primed and field finished.
- B. Interior Doors, Non-Fire-Rated:
1. Based on NAAMM HMMA Custom Guidelines:
    - a. Comply with guidelines of NAAMM HMMA 860 for Hollow Metal Doors and Frames.
    - b. Performance Level 2 - Moderate Duty, in accordance with NAAMM HMMA 805.
    - c. Physical Performance Level C, 250,000 cycles; in accordance with ANSI/SDI A250.4.
    - d. Door Face Metal Thickness: 20 gauge, 0.032 inch (0.8 mm), minimum.
  2. Door Core Material: Manufacturers standard core material/construction and in compliance with requirements.
  3. Door Thickness: 1-3/4 inches (44.5 mm), nominal.
  4. Door Finish: Factory primed and field finished.
- C. Fire-Rated Doors:
1. Based on NAAMM HMMA Custom Guidelines: Comply with NAAMM HMMA 850 requirements for fire-rated doors.
    - a. Comply with guidelines of NAAMM HMMA 860 for Hollow Metal Doors and Frames.
    - b. Performance Level 2 - Moderate Duty, in accordance with NAAMM HMMA 805.
    - c. Physical Performance Level C, 250,000 cycles; in accordance with ANSI/SDI A250.4.
    - d. Door Face Metal Thickness: 20 gauge, 0.032 inch (0.8 mm), minimum.
  2. Fire Rating: As indicated on Door Schedule, tested in accordance with UL 10C and NFPA 252 ("positive pressure fire tests").
  3. Provide units listed and labeled by UL (DIR) or ITS (DIR).
    - a. Attach fire rating label to each fire rated unit.
  4. Door Core Material: Manufacturers standard core material/construction in compliance with requirements.
  5. Door Thickness: 1-3/4 inches (44.5 mm), nominal.
  6. Door Finish: Factory primed and field finished.
  7. Fire-rated glazing to match door rating where required.

8. Products:
  - a. TruDoor, LLC; Fire-Rated Metal Door : [www.trudoor.com](http://www.trudoor.com)
  - b. Substitutions: See Section 01 6000 - Product Requirements.

#### **2.04 HOLLOW METAL FRAMES**

- A. Comply with standards and/or custom guidelines as indicated for corresponding door in accordance with applicable door frame requirements.
- B. Frame Finish: Factory primed and field finished.
- C. Exterior Door Frames: Full profile/continuously welded type.
  1. Frame Metal Thickness: 18 gauge, 0.042 inch (1.0 mm), minimum.
  2. Weatherstripping: Separate, see Section 087100.
- D. Interior Door Frames, Non-Fire Rated: Full profile/continuously welded type.
  1. Frame Metal Thickness: 18 gauge, 0.042 inch (1.0 mm), minimum.
- E. Door Frames, Fire-Rated: Full profile/continuously welded type.
  1. Fire Rating: Same as door, labeled.
  2. Terminated Stops: Provide at {CH#47806}; closed end stop terminated {CH#47807}, maximum, above floor at {CH#47808} angle.
  3. Frame Metal Thickness: 18 gauge, 0.042 inch (1.0 mm), minimum.
- F. Frames for Wood Doors: Comply with frame requirements in accordance with corresponding door.
- G. Borrowed Lites Glazing Frames: Construction and face dimensions to match door frames, and as indicated on drawings.
  1. Exterior Door = 1" insulated glazing, safety/tempered, See Section 088000 Glazing.
  2. Interior Door = 1/4" safety/tempered glazing, See Section 088000 Glazing.

#### **2.05 FINISHES**

- A. Primer: Rust-inhibiting, complying with ANSI/SDI A250.10, door manufacturer's standard.

#### **2.06 ACCESSORIES**

- A. Door Window Frames: Door window frames with glazing securely fastened within door opening.
  1. Frame Material: 18 gauge, 0.0478 inch (1.21 mm), galvanized steel.
- B. Glazing: As specified in Section 088000, factory installed.
- C. Removable Stops: Formed sheet steel, shape as indicated on drawings, mitered or butted corners; prepared for countersink style tamper proof screws.
- D. Mechanical Fasteners for Concealed Metal-to-Metal Connections: Self-drilling, self-tapping, steel with electroplated zinc finish.
- E. Grout for Frames: Mortar grout complying with ASTM C476 with maximum slump of 4 inches (102 mm) as measured in accordance with ASTM C143/C143M for hand troweling in place; plaster grout and thinner pumpable grout are prohibited.
- F. Silencers: Resilient rubber, fitted into drilled hole; provide three on strike side of single door, three on center mullion of pairs, and two on head of pairs without center mullions.
- G. Temporary Frame Spreaders: Provide for factory- or shop-assembled frames.

### **PART 3 EXECUTION**

#### **3.01 EXAMINATION**

- A. Verify existing conditions before starting work.
- B. Verify that opening sizes and tolerances are acceptable.
- C. Verify that finished walls are in plane to ensure proper door alignment.

### **3.02 INSTALLATION**

- A. Install doors and frames in accordance with manufacturer's instructions and related requirements of specified door and frame standards or custom guidelines indicated.
- B. Install fire rated units in accordance with NFPA 80.
- C. Coordinate frame anchor placement with wall construction.
- D. Grout frames in masonry construction, using hand trowel methods; brace frames so that pressure of grout before setting will not deform frames.
- E. Install door hardware as specified in Section 087100.
- F. Comply with glazing installation requirements of Section 088000.
- G. Coordinate installation of electrical connections to electrical hardware items.

### **3.03 TOLERANCES**

- A. Maximum Diagonal Distortion: 1/16 inch (1.6 mm) measured with straight edge, corner to corner.

### **3.04 ADJUSTING**

- A. Adjust for smooth and balanced door movement.

**END OF SECTION**

**SECTION 081416  
FLUSH WOOD DOORS**

**PART 1 GENERAL**

**1.01 SECTION INCLUDES**

- A. Flush wood doors; flush configuration; fire-rated and non-rated.

**1.02 RELATED REQUIREMENTS**

- A. Section 062000 - Finish Carpentry: Wood door frames.
- B. Section 081213 - Hollow Metal Frames.
- C. Section 081433 - Stile and Rail Wood Doors.
- D. Section 087100 - Door Hardware.
- E. Section 088000 - Glazing.
- F. Section 099300 - Staining and Transparent Finishing: Field finishing of doors.

**1.03 REFERENCE STANDARDS**

- A. ANSI A135.4 - Basic Hardboard; 2012 (Reaffirmed 2020).
- B. ASTM E84 - Standard Test Method for Surface Burning Characteristics of Building Materials; 2023c.
- C. ASTM E413 - Classification for Rating Sound Insulation; 2022.
- D. ASTM E2112 - Standard Practice for Installation of Exterior Windows, Doors and Skylights; 2023.
- E. AWI (QCP) - Quality Certification Program; Current Edition.
- F. AWI/AWMAC/WI (AWS) - Architectural Woodwork Standards, 2nd Edition; 2014, with Errata (2016).
- G. AWMAC/WI (NAAWS) - North American Architectural Woodwork Standards; 2021, with Errata.
- H. ICC (IBC) - International Building Code; Most Recent Edition Adopted by Authority Having Jurisdiction, Including All Applicable Amendments and Supplements.
- I. NEMA LD 3 - High-Pressure Decorative Laminates; 2005.
- J. NFPA 80 - Standard for Fire Doors and Other Opening Protectives; 2022.
- K. NFPA 252 - Standard Methods of Fire Tests of Door Assemblies; 2022.
- L. UL (DIR) - Online Certifications Directory; Current Edition.
- M. UL 10B - Standard for Fire Tests of Door Assemblies; Current Edition, Including All Revisions.
- N. UL 10C - Standard for Positive Pressure Fire Tests of Door Assemblies; Current Edition, Including All Revisions.
- O. UL 1784 - Standard for Air Leakage Tests of Door Assemblies; Current Edition, Including All Revisions.
- P. WDMA I.S. 1A - Interior Architectural Wood Flush Doors; 2021, with Errata (2022).

**1.04 SUBMITTALS**

- A. See Section 013000 - Administrative Requirements for submittal procedures.
- B. Product Data: Indicate door core materials and construction; veneer species, type and characteristics.
- C. Shop Drawings: Show doors and frames, elevations, sizes, types, swings, undercuts, beveling, blocking for hardware, factory machining, factory finishing, cutouts for glazing and other details.
  - 1. Provide information as required by AWI/AWMAC/WI (AWS) or AWMAC/WI (NAAWS).
- D. Samples: Submit two samples of door construction, 12 by 12 inches (\_\_\_ by \_\_\_ mm) in size cut from top corner of door.

- E. Samples: Submit two samples of door veneer, 8 by 10 inches (\_\_\_ by \_\_\_ mm) in size illustrating wood grain, stain color, and sheen.
- F. Certificate: Submit labels and certificates required by quality assurance and quality control programs.
- G. Manufacturer's Installation Instructions: Indicate special installation instructions.
- H. Warranty, executed in Owner's name.

### 1.05 QUALITY ASSURANCE

- A. Woodwork Quality Assurance Program:
  1. Comply with AWI (QCP) woodwork association quality assurance service/program in accordance with requirements for work specified in this section; [www.awiqcp.org/#sle](http://www.awiqcp.org/#sle).
  2. Provide labels indicating that the installed work complies with AWI/AWMAC/WI (AWS) or AWMAC/WI (NAAWS) requirements for grade or grades specified.
  3. Provide designated labels on shop drawings as required by quality assurance program.
  4. Provide designated labels on installed products as required by quality assurance program.
  5. Submit documentation upon completion of installation that verifies this work is in compliance with specified requirements.

### 1.06 DELIVERY, STORAGE, AND HANDLING

- A. Package, deliver and store doors in accordance with specified quality standard.
- B. Accept doors on site in manufacturer's packaging, and inspect for damage.
- C. Protect doors with resilient packaging sealed with heat shrunk plastic; do not store in damp or wet areas or areas where sunlight might bleach veneer; seal top and bottom edges with tinted sealer if stored more than one week, and break seal on site to permit ventilation.

### 1.07 WARRANTY

- A. See Section 017800 - Closeout Submittals for additional warranty requirements.
- B. Interior Doors: Provide manufacturer's warranty for the life of the installation.
- C. Include coverage for delamination of veneer, warping beyond specified installation tolerances, defective materials, and telegraphing core construction.

## PART 2 PRODUCTS

### 2.01 MANUFACTURERS

- A. Wood Veneer Faced Doors:
  1. Eggers Industries; [www.vtindustries.com](http://www.vtindustries.com)
  2. Masonite Architectural; [www.architectural.masonite.com/#sle](http://www.architectural.masonite.com/#sle).
  3. Substitutions: See Section 016000 - Product Requirements.

### 2.02 DOORS AND PANELS

- A. Doors: See drawings for locations and additional requirements.
  1. Wood Veneer Faced Doors: 5-ply unless otherwise indicated.
- B. Interior Doors: 1-3/4 inches (44 mm) thick unless otherwise indicated; flush construction.
  1. Wood veneer facing for field transparent finish as indicated on drawings.

### 2.03 DOOR AND PANEL CORES

- A. Fire-Rated Doors: Mineral core type, with fire resistant composite core (FD), plies and faces as indicated above; with core blocking as required to provide adequate anchorage of hardware without through-bolting.
- B. Hollow Core Doors: Type - Standard (FSHC); plies and faces as indicated above.

### 2.04 DOOR FACINGS

- A. Veneer Facing for Transparent Finish: Red oak, veneer grade in accordance with quality standard indicated, plain sliced (flat cut), with book match between leaves of veneer, running match of spliced veneer leaves assembled on door or panel face.

## **2.05 DOOR CONSTRUCTION / FABRICATION**

- A. Fabricate doors in accordance with door quality standard specified.
- B. Cores Constructed with stiles and rails:
  - 1. Provide solid blocks at lock edge for hardware reinforcement.
  - 2. Provide solid blocking for other throughbolted hardware.
- C. Where supplementary protective edge trim is required, install trim after veneer facing has been applied full-width.
- D. Factory machine doors for hardware other than surface-mounted hardware, in accordance with hardware requirements and dimensions.
- E. Factory fit doors for frame opening dimensions identified on shop drawings, with edge clearances in accordance with specified quality standard.
- F. Provide edge clearances in accordance with the quality standard specified.
- G. Vertical Exposed Edge of Stiles: Of same species as veneer facing.

## **2.06 FINISHES - WOOD VENEER DOORS**

- A. Factory finish doors in accordance with approved sample.
  - 1. Finish work in accordance with AWI - Section 1500 Factory Finishing; Premium Quality; Stained Transparent Type:
    - a. Conversion Varnish.
    - b. Catalyzed Polyurethane.
    - c. UV Cured Epoxy, Polyester, Urethane.
- B. Seal door top edge with color sealer to match door facing.

## **2.07 ACCESSORIES**

- A. Hollow Metal Door Frames: See Section 081113.
- B. Glazing: See Section 088000.
- C. Glazing Stops: Wood, of same species as door facing, butted corners; prepared for countersink style tamper proof screws.
- D. Door Hardware: See Section 087100.
  - 1. Door Peep Holes: Provide and replace door peep holes for each individual interior unit entry door.

## **PART 3 EXECUTION**

### **3.01 EXAMINATION**

- A. Verify existing conditions before starting work.
- B. Verify that opening sizes and tolerances are acceptable.
- C. Do not install doors in frame openings that are not plumb or are out-of-tolerance for size or alignment.

### **3.02 INSTALLATION**

- A. Install doors in accordance with manufacturer's instructions and specified quality standard.
  - 1. Install fire-rated doors in accordance with NFPA 80 requirements.
  - 2. Install exterior doors in accordance with ASTM E2112.
- B. Factory-Finished Doors: Do not field cut or trim; if fit or clearance is not correct, replace door.
- C. Use machine tools to cut or drill for hardware.
- D. Coordinate installation of doors with installation of frames and hardware.
- E. Coordinate installation of glazing.
- F. Install door louvers plumb and level.



**3.03 TOLERANCES**

- A. Comply with specified quality standard for fit and clearance tolerances.
- B. Comply with specified quality standard for telegraphing, warp, and squareness.

**3.04 ADJUSTING**

- A. Adjust doors for smooth and balanced door movement.
- B. Adjust closers for full closure.

**END OF SECTION**

**SECTION 084313  
ALUMINUM-FRAMED STOREFRONTS**

**PART 1 GENERAL**

**1.01 SECTION INCLUDES**

- A. Aluminum-framed storefront including perimeter trim, stools, accessories, shims, and anchors.
- B. Infill panels of glass.
- C. Aluminum doors and frames.
- D. Weatherstripping.

**1.02 RELATED REQUIREMENTS**

- A. Section 079200 - Joint Sealants: Sealing joints between frames and adjacent construction.
- B. Section 085113 - Aluminum Windows: Operable sash within glazing system.
- C. Section 087100 - Door Hardware: Hardware items other than specified in this section.
- D. Section 088000 - Glazing: Glass and glazing accessories.
- E. Section 122113 - Horizontal Louver Blinds: Attachments to framing members.

**1.03 REFERENCE STANDARDS**

- A. AAMA CW-10 - Care and Handling of Architectural Aluminum from Shop to Site; 2015.
- B. AAMA 503 - Voluntary Specification for Field Testing of Newly Installed Storefronts, Curtain Walls and Sloped Glazing Systems; 2014.
- C. AAMA 611 - Voluntary Specification for Anodized Architectural Aluminum; 2020.
- D. AAMA 1503 - Voluntary Test Method for Thermal Transmittance and Condensation Resistance of Windows, Doors and Glazed Wall Sections; 2009.
- E. ASCE 7 - Minimum Design Loads and Associated Criteria for Buildings and Other Structures; Most Recent Edition Cited by Referring Code or Reference Standard.
- F. ASTM B209/B209M - Standard Specification for Aluminum and Aluminum-Alloy Sheet and Plate; 2021a.
- G. ASTM B221 - Standard Specification for Aluminum and Aluminum-Alloy Extruded Bars, Rods, Wire, Profiles, and Tubes; 2021.
- H. ASTM B221M - Standard Specification for Aluminum and Aluminum-Alloy Extruded Bars, Rods, Wire, Profiles, and Tubes (Metric); 2021.
- I. ASTM E283/E283M - Standard Test Method for Determining Rate of Air Leakage Through Exterior Windows, Skylights, Curtain Walls, and Doors Under Specified Pressure Differences Across the Specimen; 2019.
- J. ASTM E330/E330M - Standard Test Method for Structural Performance of Exterior Windows, Doors, Skylights and Curtain Walls by Uniform Static Air Pressure Difference; 2014 (Reapproved 2021).
- K. ASTM E331 - Standard Test Method for Water Penetration of Exterior Windows, Skylights, Doors, and Curtain Walls by Uniform Static Air Pressure Difference; 2000 (Reapproved 2023).
- L. ASTM E783 - Standard Test Method for Field Measurement of Air Leakage Through Installed Exterior Windows and Doors; 2002 (Reapproved 2018).
- M. ASTM E1105 - Standard Test Method for Field Determination of Water Penetration of Installed Exterior Windows, Skylights, Doors, and Curtain Walls, by Uniform or Cyclic Static Air Pressure Difference; 2015 (Reapproved 2023).

**1.04 ADMINISTRATIVE REQUIREMENTS**

- A. Coordinate with installation of other components that comprise the exterior enclosure.

**1.05 SUBMITTALS**

- A. See Section 013000 - Administrative Requirements for submittal procedures.

- B. Product Data: Provide component dimensions, describe components within assembly, anchorage and fasteners, glass and infill, door hardware, and internal drainage details.
- C. Shop Drawings: Indicate system dimensions, framed opening requirements and tolerances, affected related work, expansion and contraction joint location and details, and field welding required.
  - 1. Include design engineer's stamp or seal on shop drawings for attachments and anchors.
- D. Samples for Verification: For aluminum-framed storefront system and components required.
- E. Product Test Reports: Based on evaluation of comprehensive tests performed by a qualified testing agency for each type of aluminum-framed storefront.
- F. Manufacturer's Certificate: Certify that the products supplied meet or exceed the specified requirements.
- G. Field Quality Control Submittals: Report of field testing for water penetration and air leakage.
- H. Manufacturer's Qualification Statement.
- I. Installer's Qualification Statement.

#### **1.06 QUALITY ASSURANCE**

- A. Manufacturer Qualifications: Company specializing in performing work of type specified and with at least three years of documented experience.
- B. Installer Qualifications: Company specializing in performing work of type specified and with at least three years of documented experience.
- C. Source Limitations: Obtain aluminum-framed storefront system through one source from a single manufacturer.

#### **1.07 FIELD CONDITIONS**

- A. Do not install sealants when ambient temperature is less than 40 degrees F (5 degrees C). Maintain this minimum temperature during and 48 hours after installation.

#### **1.08 WARRANTY**

- A. Manufacturer's Warranty: Submit, for Owner's acceptance, manufacturer's standard warranty.
  - 1. Warranty Period: Two (2) years from Date of Substantial Completion of the project, provided however that the Limited Warranty shall begin in no event later than six months from date of shipment by manufacturer.

### **PART 2 PRODUCTS**

#### **2.01 MANUFACTURERS**

- A. Basis of Design: Kawneer Company, Inc.; [www.kawneer.com/#sle](http://www.kawneer.com/#sle).
  - 1. Product: EnCORE Thermal Storefront System
- B. Other Acceptable - Aluminum-Framed Storefronts Manufacturers:
  - 1. Manko Window Systems, Inc: [www.mankowindows.com/#sle](http://www.mankowindows.com/#sle).
  - 2. Oldcastle BuildingEnvelope: [www.oldcastlebe.com/#sle](http://www.oldcastlebe.com/#sle).
  - 3. Tubelite, Inc: [www.tubeliteinc.com/#sle](http://www.tubeliteinc.com/#sle).
  - 4. Trulite Glass & Aluminum Solutions, LLC: [www.trulite.com/#sle](http://www.trulite.com/#sle).
  - 5. Substitutions: See Section 016000 - Product Requirements.

#### **2.02 ALUMINUM-FRAMED STOREFRONT**

- A. Aluminum-Framed Storefront: Factory fabricated, factory finished aluminum framing members with infill, and related flashings, anchorage and attachment devices.
  - 1. Glazing Position: Front-set.
  - 2. Finish: Superior performing organic coatings.
    - a. Factory finish all surfaces that will be exposed in completed assemblies.
    - b. Touch-up surfaces cut during fabrication so that no natural aluminum is visible in completed assemblies, including joint edges.
  - 3. Finish Color: As selected by Architect from manufacturer's standard line.

4. Fabrication: Joints and corners flush, hairline, and weatherproof, accurately fitted and secured; prepared to receive anchors and hardware; fasteners and attachments concealed from view; reinforced as required for imposed loads.
  5. Construction: Eliminate noises caused by wind and thermal movement, prevent vibration harmonics, and prevent "stack effect" in internal spaces.
  6. System Internal Drainage: Drain to the exterior by means of a weep drainage network any water entering joints, condensation occurring in glazing channel, and migrating moisture occurring within system.
  7. Expansion/Contraction: Provide for expansion and contraction within system components caused by cycling temperature range of 170 degrees F (95 degrees C) over a 12 hour period without causing detrimental effect to system components, anchorages, and other building elements.
  8. Movement: Allow for movement between storefront and adjacent construction, without damage to components or deterioration of seals.
  9. Perimeter Clearance: Minimize space between framing members and adjacent construction while allowing expected movement.
- B. Performance Requirements
1. Wind Loads: Design and size components to withstand the specified load requirements without damage or permanent set, when tested in accordance with ASTM E330/E330M, using loads 1.5 times the design wind loads and 10 second duration of maximum load.
    - a. Design Wind Loads: Comply with requirements of ASCE 7.
    - b. Member Deflection: Limit member deflection to flexure limit of glass in any direction, with full recovery of glazing materials.
  2. Water Penetration Resistance on Manufactured Assembly: No uncontrolled water on interior face, when tested in accordance with ASTM E331 at pressure differential of 8 psf (390 Pa).
  3. Air Leakage: 0.06 cfm/sq ft (0.3 L/sec sq m) maximum leakage of storefront wall area when tested in accordance with ASTM E283/E283M at 1.57 psf (75 Pa) pressure difference.
  4. Air Leakage: 0.06 cfm/sq ft (0.3 L/sec sq m) maximum leakage of storefront wall area when tested in accordance with ASTM E283/E283M at 1.57 psf (75 Pa) pressure difference.

## 2.03 COMPONENTS

- A. Aluminum Framing Members: Tubular aluminum sections, thermally broken with interior section insulated from exterior, drainage holes and internal weep drainage system.
  1. Framing members for interior applications need not be thermally broken.
  2. Glazing Stops: Flush.
- B. Glazing: See Section 088000.
- C. Swing Doors: Glazed aluminum.
  1. Thickness: 1-3/4 inches (43 mm).
  2. Top Rail: 5 inches (\_\_\_\_ mm) wide.
  3. Vertical Stiles: 5 inches (\_\_\_\_ mm) wide.
  4. Bottom Rail: 10 inches (254 mm) wide.
  5. Glazing Stops: Square.
  6. Finish: Same as storefront.

## 2.04 MATERIALS

- A. Extruded Aluminum: ASTM B221 (ASTM B221M).
- B. Sheet Aluminum: ASTM B209/B209M.
- C. Fasteners: Aluminum, nonmagnetic stainless steel or other materials to be non-corrosive and compatible with aluminum window members, trim hardware, anchors, and other components.
- D. Sill Flashing Sealant: Elastomeric, silicone or polyurethane, compatible with flashing material.
- E. Sealant for Setting Thresholds: Non-curing butyl type.

- F. Glazing Gaskets: Type to suit application to achieve weather, moisture, and air infiltration requirements.

## **2.05 FINISHES**

- A. Class I Color Anodized Finish: AAMA 611 AA-M12C22A44 Electrolytically deposited colored anodic coating not less than 0.7 mils (0.018 mm) thick.
- B. Color: As selected by Architect from manufacturer's standard range.

## **2.06 HARDWARE**

- A. Other Door Hardware: See Section 087100.

## **PART 3 EXECUTION**

### **3.01 EXAMINATION**

- A. Verify dimensions, tolerances, and method of attachment with other work.
- B. Verify that storefront wall openings and adjoining water-resistive and/or air barrier seal materials are ready to receive work of this section.

### **3.02 INSTALLATION**

- A. Install wall system in accordance with manufacturer's instructions.
- B. Attach to structure to permit sufficient adjustment to accommodate construction tolerances and other irregularities.
- C. Provide alignment attachments and shims to permanently fasten system to building structure.
- D. Align assembly plumb and level, free of warp or twist. Maintain assembly dimensional tolerances, aligning with adjacent work.
- E. Provide thermal isolation where components penetrate or disrupt building insulation.
- F. Install sill flashings. Turn up ends and edges; seal to adjacent work to form water tight dam.
- G. Where fasteners penetrate sill flashings, make watertight by seating and sealing fastener heads to sill flashing.
- H. Pack fibrous insulation in shim spaces at perimeter of assembly to maintain continuity of thermal barrier.
- I. Install glass and infill panels using glazing method required to achieve performance criteria; see Section 088000.
- J. Touch-up minor damage to factory applied finish; replace components that cannot be satisfactorily repaired.

### **3.03 TOLERANCES**

- A. Maximum Variation from Plumb: 0.06 inch per 3 feet (1.5 mm per m) non-cumulative or 0.06 inch per 10 feet (1.5 mm per 3 m), whichever is less.
- B. Maximum Misalignment of Two Adjoining Members Abutting in Plane: 1/32 inch (0.8 mm).

### **3.04 FIELD QUALITY CONTROL**

- A. Provide field testing of installed storefront system by independent laboratory in accordance with AAMA 503 during construction process and before installation of interior finishes.
  - 1. Perform a minimum of two tests in each designated area as indicated on drawings.
  - 2. Conduct tests in each area prior to 10 percent and 50 percent completion of this work.
  - 3. Field test for water penetration in accordance with ASTM E1105 with uniform static air pressure difference (Procedure A) not less than 4.18 psf (200 Pa).
    - a. Maximum allowable rate of water penetration in 15-minute test is 0.5 ounce (14 gram) that is not contained in an area with provisions to drain to exterior, or collected on surface of interior horizontal framing member.
  - 4. Field test for air leakage in accordance with ASTM E783 with uniform static air pressure difference of 1.57 psf (75 Pa).

- B. Repair or replace storefront components that have failed designated field testing, and retest to verify performance complies with specified requirements.

**3.05 ADJUSTING**

- A. Adjust operating hardware and sash for smooth operation.

**3.06 CLEANING**

- A. Remove protective material from pre-finished aluminum surfaces.
- B. Wash down surfaces with a solution of mild detergent in warm water, applied with soft, clean wiping cloths, and take care to remove dirt from corners and to wipe surfaces clean.

**3.07 PROTECTION**

- A. Protect installed products from damage until Date of Substantial Completion.

**END OF SECTION**

**SECTION 085413  
FIBERGLASS WINDOWS**

**PART 1 GENERAL**

**1.01 SECTION INCLUDES**

- A. Factory fabricated fiberglass windows with operating sash.
- B. Glazed by factory.
- C. Operating hardware.
- D. Insect screens.
- E. Perimeter sealant.

**1.02 RELATED REQUIREMENTS**

- A. Section 072500 - Weather Barriers: Sealing frames to weather barrier installed on adjacent construction.
- B. Section 079200 - Joint Sealants: Sealing joints between frames and adjacent construction.
- C. Section 088000 - Glazing.

**1.03 REFERENCE STANDARDS**

- A. AAMA/WDMA/CSA 101/I.S.2/A440 - North American Fenestration Standard/Specification for Windows, Doors, and Skylights; 2022.
- B. AAMA 502 - Voluntary Specification for Field Testing of Newly Installed Fenestration Products; 2021.
- C. ASTM E283/E283M - Standard Test Method for Determining Rate of Air Leakage Through Exterior Windows, Skylights, Curtain Walls, and Doors Under Specified Pressure Differences Across the Specimen; 2019.
- D. ASTM E331 - Standard Test Method for Water Penetration of Exterior Windows, Skylights, Doors, and Curtain Walls by Uniform Static Air Pressure Difference; 2000 (Reapproved 2023).
- E. ASTM E783 - Standard Test Method for Field Measurement of Air Leakage Through Installed Exterior Windows and Doors; 2002 (Reapproved 2018).
- F. ASTM E1105 - Standard Test Method for Field Determination of Water Penetration of Installed Exterior Windows, Skylights, Doors, and Curtain Walls, by Uniform or Cyclic Static Air Pressure Difference; 2015 (Reapproved 2023).
- G. ASTM E1332 - Standard Classification for Rating Outdoor-Indoor Sound Attenuation; 2022.
- H. ASTM E1996 - Standard Specification for Performance of Exterior Windows, Curtain Walls, Doors, and Impact Protective Systems Impacted by Windborne Debris in Hurricanes; 2023.
- I. ASTM E2112 - Standard Practice for Installation of Exterior Windows, Doors and Skylights; 2023.
- J. ASTM F588 - Standard Test Methods for Measuring the Forced Entry Resistance of Window Assemblies, Excluding Glazing Impact; 2017 (Reapproved 2023).
- K. FS L-S-125 - Screening, Insect, Nonmetallic; 1972b, with Notice (1987).

**1.04 SUBMITTALS**

- A. See Section 013000 - Administrative Requirements, for submittal procedures.
- B. Product Data: Provide component dimensions, anchors, fasteners, glass, internal drainage details, and \_\_\_\_\_.
- C. Performance Validation: Provide specified performance validation before submitting shop drawings or starting fabrication.
- D. Shop Drawings: Indicate opening dimensions, framed opening tolerances, affected related work, installation requirements.
- E. Samples: Submit one 6 x 6 inch (\_\_\_\_ x \_\_\_\_ mm) in size, illustrating window frame section.

- F. Grade Substantiation: Prior to submitting shop drawings or starting fabrication, submit one of the following showing compliance with specified grade:
  - 1. Evidence of AAMA Certification.
  - 2. Evidence of WDMA Certification.
  - 3. Evidence of CSA Certification.
  - 4. Test report(s) by independent testing agency itemizing compliance and acceptable to authorities having jurisdiction.
- G. Field Quality Control Submittals: Report of field testing for water penetration and air leakage.
- H. Warranty Documentation: Submit manufacturer warranty and ensure that forms have been completed in Owner's name and registered with manufacturer.

### **1.05 QUALITY ASSURANCE**

- A. Manufacturer Qualifications: Company specializing in manufacturing products specified in this section, with not less than three years of documented experience.
- B. Installer Qualifications: Company specializing in performing work of the type specified and with at least three years of documented experience.

### **1.06 DELIVERY, STORAGE, AND HANDLING**

- A. Protect finished surfaces with wrapping. Do not use adhesive papers or sprayed coatings that bond when exposed to sunlight or weather.
- B. Jig, brace, and box the window frame assemblies for transport to minimize flexing of members or joints.

### **1.07 FIELD CONDITIONS**

- A. Do not install sealants when ambient temperature is less than 40 degrees F (5 degrees C).
- B. Maintain this minimum temperature during and after installation of sealants.

### **1.08 WARRANTY**

- A. See Section 017800 - Closeout Submittals, for additional warranty requirements.

## **PART 2 PRODUCTS**

### **2.01 MANUFACTURERS**

- A. Fiberglass Windows:
  - 1. Marvin Corporation; Marvin Elevate Fiberglass Windows: [www.marvin.com/products/collections/elevate](http://www.marvin.com/products/collections/elevate)
    - a. Basis of Design; See Drawings for locations.
  - 2. Pella Corporation; Pella Impervia Windows: [www.pella.com/ideas/windows/fiberglass](http://www.pella.com/ideas/windows/fiberglass)
  - 3. Substitutions: See Section 016000 - Product Requirements.

### **2.02 WINDOW UNITS**

- A. Fiberglass Windows: Hollow, tubular, multi-layer fiber reinforced material; factory fabricated; with vision glass, related flashings, anchorage and attachment devices.
  - 1. Performance Requirements: AAMA/WDMA/CSA 101/I.S.2/ A440 - 05.
  - 2. Configuration: As indicated on drawings .
  - 3. Product Type: H - Hung window, vertically sliding in accordance with AAMA/WDMA/CSA 101/I.S.2/A440.
  - 4. Color: White.
  - 5. Movement: Accommodate movement between window and perimeter framing and deflection of lintel, without damage to components or deterioration of seals.
  - 6. System Internal Drainage: Drain to the exterior by means of a weep drainage network any water entering joints, condensation occurring in glazing channel, and migrating moisture occurring within system.
  - 7. Thermal Movement: Design to accommodate thermal movement caused by 100 degrees F (34 degrees C) temperature change without buckling stress on glass, joint seal failure, damaging loads on structural elements, damaging loads on fasteners, reduction in



performance or other detrimental effects.

- B. Performance Requirements: Provide products that comply with the following:
  - 1. Performance Validation: Windows shall comply with AAMA/WDMA/CSA 101/I.S.2/A440 performance requirements as indicated by having AAMA, WDMA, or CSA certified label, or an independent test report for indicated products itemizing compliance and acceptable by authorities having jurisdiction.
  - 2. Assembly: To accommodate, without damage to components or deterioration of seals, movement between window and perimeter framing, deflection of lintel.
  - 3. Vapor Seal: No vapor seal failure at interior static pressure of 1 inch (25 mm), 72 degrees F (22 degrees C), and 40 percent relative humidity.
  - 4. System Internal Drainage: Drain water entering joints, condensation occurring in glazing channels, or migrating moisture occurring within system, to the exterior by a weep drainage network.
  - 5. Air and Vapor Seal: Maintain continuous air barrier and vapor retarder throughout assembly, primarily in line with inside pane of glass and heel bead of glazing compound. Position thermal insulation on exterior surface of air barrier and vapor retarder.
  - 6. Thermal Movement: Design sections to permit movement caused by thermal expansion and contraction of fiberglass to suit glass, infill, and perimeter opening construction.
  - 7. Design Temperature Range: 120 F degrees (67 C degrees).

### 2.03 COMPONENTS

- A. Insect Screen Frame: Rolled aluminum frame of rectangular sections; fit with adjustable hardware; nominal size similar to operable glazed unit.
- B. Insect Screens: FS L-S-125 woven plastic mesh; 14/18 mesh size.
  - 1. Color: Black.
- C. Sealant for Setting Sills and Sill Flashing: Non-curing butyl type.
  - 1. See Section 079200 for additional requirements.

### 2.04 GLASS AND GLAZING MATERIALS

- A. Glass and Glazing Materials:
  - 1. Glass in Exterior Lights: Type Double glass with low e coating on No. 3 glass surface. Minimum U value = 0.26, SHGC = 0.34, Visible Transmittance = 0.58.

### 2.05 SEALANT MATERIALS

### 2.06 HARDWARE

- A. Casement and Awning Sash: Zinc die-cast steel worm-gear operator with Painted finish.
  - 1. Casement and Awning Sash Lock: Folding arm crank.
  - 2. Compliant with ADA requirements for mounting height and operation force.
- B. Double Hung Sash: Metal and nylon spiral friction slide cylinder, each sash, each jamb.
  - 1. Sash Lock: Self-aligning, cam-action lock.
- C. Window Opening Control Devices (WOCD): Provide operable window sash hardware that limits openings to only allow passage of 4 inch (102 mm) diameter rigid sphere or less, and are easily releasable to fully open without use of keys, tools, or special knowledge. \*Provide WOCD for windows at levels above grade. Not required for windows in rooms at grade level.
- D. Finish For Exposed Hardware: Match window finish.

### 2.07 FABRICATION

- A. Fabricate framing, mullions and sash members with fusion welded corners and joints, in a rigid jig. Supplement frame sections with internal reinforcement where required for structural rigidity.
- B. Form snap-in glass stops, closure molds, weather stops, and flashings for tight fit into window frame section.
- C. Form weather stop flange to perimeter of unit.
- D. Fabricate components with minimum clearances and shim spacing around perimeter of assembly, yet enabling installation and dynamic movement of perimeter seal.

- E. Arrange fasteners to be concealed from view.
- F. Permit internal drainage weep holes and channels to migrate moisture to exterior. Provide internal drainage of glazing spaces to exterior through weep holes.
- G. Assemble insect screen frame, miter and reinforced frame corners. Fit mesh taut into frame and secure. Fit frame with four spring loaded steel pin retainers.
- H. Factory glaze window units.

### **PART 3 EXECUTION**

#### **3.01 INSTALLATION**

- A. Install windows in accordance with manufacturer's instructions.
- B. Attach window frame and shims to perimeter opening to accommodate construction tolerances and other irregularities.
- C. Align window plumb and level, free of warp or twist. Maintain dimensional tolerances and alignment with adjacent work.
- D. Provide thermal isolation where components penetrate or disrupt building insulation. Pack fibrous insulation in shim spaces at perimeter of assembly to maintain continuity of thermal barrier.
- E. Coordinate attachment and seal of perimeter air and vapor barrier materials.
- F. Install glass and infill panels in accordance with Section 088000, to glazing method required to achieve performance criteria.

#### **3.02 FIELD QUALITY CONTROL**

- A. Provide services of fiberglass window manufacturer's field representative to observe for proper installation of system and submit report.
- B. Provide field testing of installed fiberglass windows by independent laboratory in accordance with AAMA 502 and AAMA/WDMA/CSA 101/I.S.2/A440 during construction process and before installation of interior finishes.
  - 1. Field test for water penetration in accordance with ASTM E1105 using Procedure B - cyclic static air pressure difference; test pressure shall not be less than 1.9 psf (91 Pa).
  - 2. Field test for air leakage in accordance with ASTM E783 with uniform static air pressure difference of 6.27 psf (300 Pa).
- C. Repair or replace fenestration components that have failed designated field testing, and retest to verify performance complies with manufacturer's written installation requirements.

#### **3.03 ADJUSTING**

- A. Adjust hardware for smooth operation and secure weathertight closure.

#### **3.04 CLEANING**

- A. Remove protective material from pre-finished surfaces.
- B. Wash surfaces by method recommended and acceptable to window manufacturer; rinse and wipe surfaces clean.
- C. Remove excess glazing sealant by moderate use of mineral spirits or other solvent acceptable to sealant manufacturer.

**END OF SECTION**

## SECTION 087100 - DOOR HARDWARE

### PART 1 - GENERAL

#### 1.01 SUMMARY

##### A. Section includes:

1. Mechanical and electrified door hardware
2. Electronic access control system components

##### B. Section excludes:

1. Windows
2. Cabinets (casework), including locks in cabinets
3. Signage
4. Toilet accessories
5. Overhead doors

##### C. Related Sections:

1. Division 01 Section "Alternates" for alternates affecting this section.
2. Division 06 Section "Rough Carpentry"
3. Division 06 Section "Finish Carpentry"
4. Division 07 Section "Joint Sealants" for sealant requirements applicable to threshold installation specified in this section.
5. Division 08 Sections:
  - a. "Metal Doors and Frames"
  - b. "Flush Wood Doors"
  - c. "Aluminum-Framed Entrances and Storefronts"
6. Division 26 "Electrical" sections for connections to electrical power system and for low-voltage wiring.
7. Division 28 "Electronic Safety and Security" sections for coordination with other components of electronic access control system and fire alarm system.

#### 1.02 REFERENCES

##### A. UL LLC

1. UL 10B - Fire Test of Door Assemblies
2. UL 10C - Positive Pressure Test of Fire Door Assemblies
3. UL 1784 - Air Leakage Tests of Door Assemblies
4. UL 305 - Panic Hardware

##### B. DHI - Door and Hardware Institute

1. Sequence and Format for the Hardware Schedule
2. Recommended Locations for Builders Hardware
3. Keying Systems and Nomenclature
4. Installation Guide for Doors and Hardware

##### C. NFPA – National Fire Protection Association

1. NFPA 70 – National Electric Code
2. NFPA 80 – 2016 Edition – Standard for Fire Doors and Other Opening Protectives
3. NFPA 101 – Life Safety Code
4. NFPA 105 – Smoke and Draft Control Door Assemblies
5. NFPA 252 – Fire Tests of Door Assemblies

D. ANSI - American National Standards Institute

1. ANSI A117.1 – 2017 Edition – Accessible and Usable Buildings and Facilities
2. ANSI/BHMA A156.1 - A156.29, and ANSI/BHMA A156.31 - Standards for Hardware and Specialties
3. ANSI/BHMA A156.28 - Recommended Practices for Keying Systems
4. ANSI/WDMA I.S. 1A - Interior Architectural Wood Flush Doors
5. ANSI/SDI A250.8 - Standard Steel Doors and Frames

1.03 SUBMITTALS

A. General:

1. Submit in accordance with Conditions of Contract and Division 01 Submittal Procedures.
2. Prior to forwarding submittal:
  - a. Review drawings and Sections from related trades to verify compatibility with specified hardware.
  - b. Highlight, encircle, or otherwise specifically identify on submittals: deviations from Contract Documents, issues of incompatibility or other issues which may detrimentally affect the Work.

B. Action Submittals:

1. Product Data: Submit technical product data for each item of door hardware, installation instructions, maintenance of operating parts and finish, and other information necessary to show compliance with requirements.
2. Riser and Wiring Diagrams: After final approval of hardware schedule, submit details of electrified door hardware, indicating:
  - a. Wiring Diagrams: For power, signal, and control wiring and including:
    - 1) Details of interface of electrified door hardware and building safety and security systems.
    - 2) Schematic diagram of systems that interface with electrified door hardware.
    - 3) Point-to-point wiring.
    - 4) Risers.
3. Samples for Verification: If requested by Architect, submit production sample of requested door hardware unit in finish indicated and tagged with full description for coordination with schedule.
  - a. Samples will be returned to supplier. Units that are acceptable to Architect may, after final check of operations, be incorporated into Work, within limitations of key coordination requirements.
4. Door Hardware Schedule:
  - a. Submit concurrent with submissions of Product Data, Samples, and Shop Drawings. Coordinate submission of door hardware schedule with scheduling requirements of other work to facilitate fabrication of other work critical in Project construction schedule.

- b. Submit under direct supervision of a Door Hardware Institute (DHI) certified Architectural Hardware Consultant (AHC) or Door Hardware Consultant (DHC) with hardware sets in vertical format as illustrated by Sequence of Format for the Hardware Schedule published by DHI.
  - c. Indicate complete designations of each item required for each opening, include:
    - 1) Door Index: door number, heading number, and Architect's hardware set number.
    - 2) Quantity, type, style, function, size, and finish of each hardware item.
    - 3) Name and manufacturer of each item.
    - 4) Fastenings and other pertinent information.
    - 5) Location of each hardware set cross-referenced to indications on Drawings.
    - 6) Explanation of all abbreviations, symbols, and codes contained in schedule.
    - 7) Mounting locations for hardware.
    - 8) Door and frame sizes and materials.
    - 9) Degree of door swing and handing.
    - 10) Operational Description of openings with electrified hardware covering egress, ingress (access), and fire/smoke alarm connections.
5. Key Schedule:
- a. After Keying Conference, provide keying schedule that includes levels of keying, explanations of key system's function, key symbols used, and door numbers controlled.
  - b. Use ANSI/BHMA A156.28 "Recommended Practices for Keying Systems" as guideline for nomenclature, definitions, and approach for selecting optimal keying system.
  - c. Provide 3 copies of keying schedule for review prepared and detailed in accordance with referenced DHI publication. Include schematic keying diagram and index each key to unique door designations.
  - d. Index keying schedule by door number, keyset, hardware heading number, cross keying instructions, and special key stamping instructions.
  - e. Provide one complete bitting list of key cuts and one key system schematic illustrating system usage and expansion. Forward bitting list, key cuts and key system schematic directly to Owner, by means as directed by Owner.
  - f. Prepare key schedule by or under supervision of supplier, detailing Owner's final keying instructions for locks.
- C. Informational Submittals:
- 1. Provide Qualification Data for Supplier, Installer and Architectural Hardware Consultant.
  - 2. Provide Product Data:
    - a. Certify that door hardware approved for use on types and sizes of labeled fire-rated doors complies with listed fire-rated door assemblies.
    - b. Include warranties for specified door hardware.
- D. Closeout Submittals:
- 1. Operations and Maintenance Data: Provide in accordance with Division 01 and include:
    - a. Complete information on care, maintenance, and adjustment; data on repair and replacement parts, and information on preservation of finishes.
    - b. Catalog pages for each product.
    - c. Final approved hardware schedule edited to reflect conditions as installed.
    - d. Final keying schedule
    - e. Copy of warranties including appropriate reference numbers for manufacturers to identify project.
    - f. As-installed wiring diagrams for each opening connected to power, both low voltage and 110 volts.

E. Inspection and Testing:

1. Submit written reports to the Owner and Authority Having Jurisdiction (AHJ) of the results of functional testing and inspection for:
  - a. Fire door assemblies, in compliance with NFPA 80.
  - b. Required egress door assemblies, in compliance with NFPA 101.

1.04 QUALITY ASSURANCE

A. Qualifications and Responsibilities:

1. Supplier: Recognized architectural hardware supplier with a minimum of 5 years documented experience supplying both mechanical and electromechanical door hardware similar in quantity, type, and quality to that indicated for this Project. Supplier to be recognized as a factory direct distributor by the manufacturer of the primary materials with a warehousing facility in the Project's vicinity. Supplier to have on staff, a certified Architectural Hardware Consultant (AHC) or Door Hardware Consultant (DHC) available to Owner, Architect, and Contractor, at reasonable times during the Work for consultation.
2. Installer: Qualified tradesperson skilled in the application of commercial grade hardware with experience installing door hardware similar in quantity, type, and quality as indicated for this Project.
3. Architectural Hardware Consultant: Person who is experienced in providing consulting services for door hardware installations that are comparable in material, design, and extent to that indicated for this Project and meets these requirements:
  - a. For door hardware: DHI certified AHC or DHC.
  - b. Can provide installation and technical data to Architect and other related subcontractors.
  - c. Can inspect and verify components are in working order upon completion of installation.
  - d. Capable of producing wiring diagram and coordinating installation of electrified hardware with Architect and electrical engineers.
4. Single Source Responsibility: Obtain each type of door hardware from single manufacturer.

B. Certifications:

1. Fire-Rated Door Openings:
  - a. Provide door hardware for fire-rated openings that complies with NFPA 80 and requirements of authorities having jurisdiction.
  - b. Provide only items of door hardware that are listed products tested by UL LLC, Intertek Testing Services, or other testing and inspecting organizations acceptable to authorities having jurisdiction for use on types and sizes of doors indicated, based on testing at positive pressure and according to NFPA 252 or UL 10C and in compliance with requirements of fire-rated door and door frame labels.
2. Smoke and Draft Control Door Assemblies:
  - a. Provide door hardware that meets requirements of assemblies tested according to UL 1784 and installed in compliance with NFPA 105
  - b. Comply with the maximum air leakage of 0.3 cfm/sq. ft. (3 cu. m per minute/sq. m) at tested pressure differential of 0.3-inch wg (75 Pa) of water.
3. Electrified Door Hardware
  - a. Listed and labeled as defined in NFPA 70, Article 100, by testing agency acceptable to authorities having jurisdiction.

4. Accessibility Requirements:
  - a. Comply with governing accessibility regulations cited in "REFERENCES" article 087100, 1.02.D3 herein for door hardware on doors in an accessible route. This project must comply with all Federal Americans with Disability Act regulations and all Local Accessibility Regulations.

#### C. Pre-Installation Meetings

1. Keying Conference
  - a. Incorporate keying conference decisions into final keying schedule after reviewing door hardware keying system including:
    - 1) Function of building, flow of traffic, purpose of each area, degree of security required, and plans for future expansion.
    - 2) Preliminary key system schematic diagram.
    - 3) Requirements for key control system.
    - 4) Requirements for access control.
    - 5) Address for delivery of keys.
2. Pre-installation Conference
  - a. Review and finalize construction schedule and verify availability of materials, Installer's personnel, equipment, and facilities needed to make progress and avoid delays.
  - b. Inspect and discuss preparatory work performed by other trades.
  - c. Inspect and discuss electrical roughing-in for electrified door hardware.
  - d. Review sequence of operation for each type of electrified door hardware.
  - e. Review required testing, inspecting, and certifying procedures.
  - f. Review questions or concerns related to proper installation and adjustment of door hardware.
3. Electrified Hardware Coordination Conference:
  - a. Prior to ordering electrified hardware, schedule and hold meeting to coordinate door hardware with security, electrical, doors and frames, and other related suppliers.

#### 1.05 DELIVERY, STORAGE, AND HANDLING

- A. Inventory door hardware on receipt and provide secure lock-up for hardware delivered to Project site. Promptly replace products damaged during shipping.
- B. Tag each item or package separately with identification coordinated with final door hardware schedule, and include installation instructions, templates, and necessary fasteners with each item or package. Deliver each article of hardware in manufacturer's original packaging.
- C. Maintain manufacturer-recommended environmental conditions throughout storage and installation periods.
- D. Provide secure lock-up for door hardware delivered to Project. Control handling and installation of hardware items so that completion of Work will not be delayed by hardware losses both before and after installation.
- E. Handle hardware in manner to avoid damage, marring, or scratching. Correct, replace or repair products damaged during Work. Protect products against malfunction due to paint, solvent, cleanser, or any chemical agent.
- F. Deliver keys to manufacturer of key control system for subsequent delivery to Owner.

## 1.06 COORDINATION

- A. Coordinate layout and installation of floor-recessed door hardware with floor construction. Cast anchoring inserts into concrete.
- B. Installation Templates: Distribute for doors, frames, and other work specified to be factory or shop prepared. Check Shop Drawings of other work to confirm that adequate provisions are made for locating and installing door hardware to comply with indicated requirements.
- C. Security: Coordinate installation of door hardware, keying, and access control with Owner's security consultant.
- D. Electrical System Roughing-In: Coordinate layout and installation of electrified door hardware with connections to power supplies and building safety and security systems.

## 1.07 WARRANTY

- A. Manufacturer's standard form in which manufacturer agrees to repair or replace components of door hardware that fail in materials or workmanship within published warranty period.
  - 1. Warranty does not cover damage or faulty operation due to improper installation, improper use or abuse.
  - 2. Warranty Period: Beginning from date of Substantial Completion, for durations indicated in manufacturer's published listings.
    - a. Mechanical Warranty
      - 1) Locks: 10 Years
      - 2) Exit Devices: 10 Years
      - 3) Closers: 10 Year
    - b. Electrical Warranty
      - 1) Exit Devices: 1 year
      - 2) Auto Operators: 1 Year

## 1.08 MAINTENANCE

- A. Furnish complete set of special tools required for maintenance and adjustment of hardware, including changing of cylinders.
- B. Turn over unused materials to Owner for maintenance purposes.

## PART 2 - PRODUCTS

### 2.01 MANUFACTURERS

- A. The Owner requires use of certain products for their unique characteristics and project suitability to ensure continuity of existing and future performance and maintenance standards. After investigating available product offerings, the Awarding Authority has elected to prepare proprietary specifications. These products are specified with the notation: "No Substitute."
  - 1. Where "No Substitute" is noted, submittals and substitution requests for other products will not be considered.



- B. Approval of manufacturers and/or products other than those listed as "Scheduled Manufacturer" or "Acceptable Manufacturers" in the individual article for the product category shall be in accordance with QUALITY ASSURANCE article, herein.
- C. Approval of products from manufacturers indicated in "Acceptable Manufacturers" is contingent upon those products providing all functions and features and meeting all requirements of scheduled manufacturer's product.
- D. Where specified hardware is not adaptable to finished shape or size of members requiring hardware, furnish suitable types having same operation and quality as type specified, subject to Architect's approval.

## 2.02 MATERIALS

### A. Fabrication

- 1. Provide door hardware manufactured to comply with published templates generally prepared for machine, wood, and sheet metal screws. provide screws according to manufacturer's recognized installation standards for application intended.
  - 2. Finish exposed screws to match hardware finish, or, if exposed in surfaces of other work, to match finish of this other work including prepared for paint surfaces to receive painted finish.
  - 3. Provide concealed fasteners wherever possible for hardware units exposed when door is closed. Coordinate with "Metal Doors and Frames", "Flush Wood Doors", "Stile and Rail Wood Doors" to ensure proper reinforcements. Advise the Architect where visible fasteners, such as thru bolts, are required.
- B. Provide screws, bolts, expansion shields, drop plates and other devices necessary for hardware installation.
- 1. Where fasteners are exposed to view: Finish to match adjacent door hardware material.
  - 2. For closers and panic devices: Verify with Architect and/or Owner if thru-bolts are required at specific door materials.

## 2.03 HINGES

### A. Manufacturers and Products:

- 1. Scheduled Manufacturer and Product:
  - a. Ives 5BB series
- 2. Acceptable Manufacturers and Products:
  - a. Hager BB series
  - b. McKinney TB series
  - c. Stanley (Best/Dormakaba) FBB series

### B. Requirements:

- 1. Provide hinges conforming to ANSI/BHMA A156.1.
- 2. Provide five knuckle, ball bearing hinges.
- 3. Hinge Height:
  - a. 1-3/4 inch (44 mm) thick doors, up to and including 36 inches (914 mm) wide: 4-1/2 inches (114 mm) high

- b. 1-3/4 inch (44 mm) thick doors over 36 inches (914 mm) wide: 5 inches (127 mm) high
  - c. 2 inches or thicker doors: 5 inches (127 mm) high, regardless of door width
4. Hinge Width: 4-1/2 inches (114 mm) wide typical. Adjust hinge width for door, frame, and wall conditions to allow proper degree of opening.
  5. Hinge quantity: Provide three hinges per door leaf for doors 90 inches (2286 mm) or less in height, and one additional hinge for each 30 inches (762 mm) of additional door height.
  6. Hinge Pins: Except as otherwise indicated, provide hinge pins as follows:
    - a. Steel Hinges: Steel pins
    - b. Non-Ferrous Hinges: Stainless steel pins
    - c. Out-Swinging Exterior Doors: Non-removable pins
    - d. Out-Swinging Interior Lockable Doors: Non-removable pins
    - e. Interior Non-lockable Doors: Non-rising pins

## 2.04 SPRING HINGES

### A. Manufacturers and Products:

1. Scheduled Manufacturer and Product:
  - a. Ives 3SP series
2. Acceptable Manufacturers and Products:
  - a. Hager 1250 series
  - b. McKinney 1502 series
  - c. Best 2060 series

### B. Requirements:

1. Provide hinges conforming to ANSI/BHMA A156.1.
2. Provide 3 knuckle, steel based, spring full mortise hinges.
3. Adjust hinge width for door, frame, and wall conditions to allow proper degree of opening.
4. Provide two spring hinges and one bearing hinge per door leaf for doors 90 inches (2286 mm) or less in height. Do not use spring hinges of door 96 inches and greater in height.
5. Where new hinges are specified for existing doors or existing frames, provide new hinges of identical size to hinge preparation present in existing door or existing frame.

## 2.05 CONTINUOUS HINGES

### A. Manufacturers:

1. Scheduled Manufacturer:
  - a. Ives
2. Acceptable Manufacturers:
  - a. Select
  - b. Pemko

### B. Requirements:

1. Provide aluminum geared continuous hinges conforming to ANSI/BHMA A156.26, Grade 1.
2. Provide aluminum geared continuous hinges, where specified in the hardware sets, fabricated from 6063-T6 aluminum.

3. Provide split nylon bearings at each hinge knuckle for quiet, smooth, self-lubricating operation.
4. Provide hinges capable of supporting door weights up to 450 pounds, and successfully tested for 1,500,000 cycles.
5. On fire-rated doors, provide aluminum geared continuous hinges classified for use on rated doors by testing agency acceptable to authority having jurisdiction.
6. Provide aluminum geared continuous hinges with electrified option scheduled in the hardware sets. Provide with number and gage of wires enough to accommodate electric function of specified hardware.
7. Provide hinges 1 inch (25 mm) shorter in length than nominal height of door, unless otherwise noted or door details require shorter length and with symmetrical hole pattern.
8. Adjust hinge model/width as required for door thickness or construction.

## 2.06 ELECTRIC POWER TRANSFER

### A. Manufacturers:

1. Scheduled Manufacturer and Product:
  - a. Von Duprin EPT-10
2. Acceptable Manufacturers and Products:
  - a. Securitron CEPT-10

### B. Requirements:

1. Provide power transfer with electrified options as scheduled in the hardware sets. Provide with number and gage of wires enough to accommodate electric function of specified hardware.
2. Locate electric power transfer per manufacturer's template and UL requirements, unless interference with operation of door or other hardware items.

## 2.07 CYLINDRICAL LOCKS – GRADE 1

### A. Manufacturers and Products:

1. Scheduled Manufacturer and Product:
  - a. Falcon T series
2. Acceptable Manufacturers and Products:
  - a. Sargent 10-Line
  - b. Best 9K series

### B. Requirements:

1. Provide cylindrical locks conforming to ANSI/BHMA A156.2 Series 4000, Grade 1, and UL Listed for 3-hour fire doors.
2. Cylinders: Refer to "KEYING" article, herein.
3. Provide locks with standard 2-3/4 inches (70 mm) backset, unless noted otherwise, with 1/2-inch latch throw. Provide proper latch throw for UL listing at pairs.
4. Provide locksets with separate anti-rotation thru-bolts, and no exposed screws.
5. Provide independently operating levers with two external return spring cassettes mounted under roses to prevent lever sag.
6. Provide standard ASA strikes unless extended lip strikes are necessary to protect trim.
7. Provide electrified options as scheduled in the hardware sets.

8. Lever Trim: Solid cast levers without plastic inserts and wrought roses on both sides.
  - a. Lever Design: Falcon Dane (DAN).

## 2.08 MORTISE LOCKS (@ PRIVACY LOCKS WITH OCCUPIED INDICATORS)

### A. Manufacturers and Products:

1. Scheduled Manufacturer and Product:
  - a. Falcon MA series
2. Acceptable Manufacturers and Products:
  - a. Sargent 8200 series
  - b. Best 45H series

### B. Requirements:

1. Provide mortise locks conforming to ANSI/BHMA A156.13 Series 1000, Grade 1, and UL Listed for 3-hour fire doors.
2. Provide locks manufactured from heavy gauge steel, containing components of steel with a zinc dichromate plating for corrosion resistance.
3. Provide lock case that is multi-function and field reversible for handing without opening case. Cylinders: Refer to "KEYING" article, herein.
4. Provide locks with standard 2-3/4 inches (70 mm) backset with full 3/4 inch (19 mm) throw stainless steel mechanical anti-friction latchbolt. Provide deadbolt with full 1-inch (25 mm) throw, constructed of stainless steel.
5. Provide standard ASA strikes unless extended lip strikes are necessary to protect trim.
6. Provide electrified options as scheduled in the hardware sets. Where scheduled, provide a request to exit (RX) switch that is actuated with rotation of inside lever.
7. Lever Trim: Solid brass, bronze, or stainless steel, cast or forged in design specified, with wrought roses and external lever spring cages. Provide thru-bolted levers with 2-piece spindles.
  - a. Lever Design: Falcon Dane Gala (DG).

## 2.09 CYLINDRICAL LOCKS – GRADE 2

### A. Manufacturers and Products:

1. Scheduled Manufacturer and Product:
  - a. Falcon W series
2. Acceptable Manufacturers and Products:
  - a. Best 73KC series
  - b. Sargent 6500 series

### B. Requirements:

1. Provide cylindrical locks conforming to ANSI/BHMA A156.2 Series 4000, Grade 2, and UL Listed for 3-hour fire doors.
2. Cylinders: Refer to "KEYING" article, herein.
3. Provide locks with standard 2-3/4 inches (70 mm) backset, unless noted otherwise, with 1/2-inch latch throw. Provide proper latch throw for UL listing at pairs.
4. Provide locksets with separate anti-rotation thru-bolts, and no exposed screws.
5. Provide independently operating levers with two external return spring cassettes mounted under roses to prevent lever sag.

6. Provide standard ASA strikes unless extended lip strikes are necessary to protect trim.
7. Lever Trim: Solid cast levers without plastic inserts and wrought roses on both sides.
  - a. Lever Design: Falcon Dane (DAN).

## 2.10 TUBULAR LOCKS – GRADE 3

### A. Manufacturers and Products:

1. Scheduled Manufacturer and Product:
  - a. Schlage J series
2. Acceptable Manufacturers and Products:
  - a. Hager 3300 series
  - b. PDQ Industries SM series

### B. Requirements:

1. Provide tubular locks conforming to ANSI/BHMA A156.2 Series 4000, Grade 3, and UL Listed for 3-hour fire doors.
2. Cylinders: Refer to "KEYING" article, herein.
3. Provide locks with standard 2-3/8 inches (60 mm) adjustable to 2-3/4 inches (70 mm) backset with 1/2-inch (13 mm) latch throw. Provide 2-3/4-inch (70 mm) backset, unless 2-3/8 inches (60 mm) is required by door or frame detail or noted otherwise.
4. Provide locksets that fit standard 2-1/8 inches (54 mm) diameter bore without the use of thru bolts.
5. Locksets adjustable to fit in 1-3/8 inches (35 mm) or 1-3/4 inches (44 mm) door thickness.
6. Provide standard T-strikes unless extended lip strikes are necessary to protect trim.
7. Lever Trim: Solid cast levers without plastic inserts and wrought roses on both sides.
  - a. Lever Design: Schlage Marin (MAR).

## 2.11 DEADBOLTS

### A. Manufacturers and Products:

1. Scheduled Manufacturer and Product:
  - a. Schlage B60 Series
2. Acceptable Manufacturers and Products:
  - a. Dormakaba D800/DB600 Series
  - b. Sargent 470 Series

### B. Requirements:

1. Provide deadbolt conforming to ANSI/BHMA A156.
2. Cylinders: Refer to "KEYING" article, herein.
3. Provide deadbolts with standard 2-3/4 inches (70 mm) backset. Provide 2-3/8 inches (60 mm) where noted or if door or frame detail requires. Provide deadbolt with full 1-inch (25 mm) throw, constructed of steel alloy.
4. Provide manufacturer's standard strike.

## 2.12 EXIT DEVICES

A. Manufacturers and Products:

1. Scheduled Manufacturer and Product:
  - a. Falcon 24/25 series
2. Acceptable Manufacturers and Products:
  - a. Sargent 19-43-GL-80 series
  - b. Precision Apex series

B. Requirements:

1. Provide exit devices tested to ANSI/BHMA A156.3 Grade 1 and UL listed for Panic Exit or Fire Exit Hardware.
2. Cylinders: Refer to "KEYING" article, herein.
3. Provide touchpad type exit devices, fabricated of brass, bronze, stainless steel, or aluminum, plated to standard architectural finishes to match balance of door hardware.
4. Touchpad must extend a minimum of one half of door width. No plastic inserts are allowed in touchpads.
5. Provide exit devices with deadlatching feature for security and for future addition of alarm kits and/or other electrified requirements.
6. Provide flush end caps for exit devices.
7. Provide exit devices with manufacturer's approved strikes.
8. Provide exit devices cut to door width and height. Install exit devices at height recommended by exit device manufacturer, allowable by governing building codes, and approved by Architect.
9. Mount mechanism case flush on face of doors or provide spacers to fill gaps behind devices. Where glass trim or molding projects off face of door, provide glass bead kits.
10. Provide cylinder or hex-key dogging as specified at non fire-rated openings.
11. Removable Mullions: 2 inches (51 mm) x 3 inches (76 mm) steel tube. Where scheduled as keyed removable mullion, provide type that can be removed by use of a keyed cylinder, which is self-locking when re-installed.
12. Provide factory drilled weep holes for exit devices used in full exterior application, highly corrosive areas, and where noted in hardware sets.
13. Provide electrified options as scheduled.
14. Provide exit devices with optional trim designs to match other lever and pull designs used on the project.

## 2.13 EXIT DEVICES

A. Manufacturers and Products:

1. Scheduled Manufacturer and Product:
  - a. Falcon 19 series
2. Acceptable Manufacturers and Products:
  - a. Precision Reliant 5000 series
  - b. Sargent 20 series

B. Requirements:

1. Provide narrow stile exit devices tested to ANSI/BHMA A156.3 Grade 1 and UL listed for Panic Exit or Fire Exit Hardware.
2. Cylinders: Refer to "KEYING" article, herein.
3. Provide deadlatching feature for security and for future addition of alarm kits or other electrical requirements.

4. Provide manufacturer's standard strikes.
5. Provide exit devices cut to door width and height. Locate exit devices at height recommended by exit device manufacturer, allowable by governing building codes, and approved by Architect.
6. Mechanism Case: Mount flush on face of doors or provide spacers to fill gaps behind devices. Where glass trim or molding projects off face of door, provide glass bead kits.
7. Removable Mullions: 2 inches (51 mm) x 3 inches (76 mm) steel tube. Where scheduled as keyed removable mullion, provide type that can be removed by use of a keyed cylinder, which is self-locking when re-installed.
8. Provide UL labeled fire exit devices for fire rated openings.
9. Provide exit devices with optional trim designs to match other lever and pull designs used on the project.

## 2.14 ELECTRIC STRIKES

### A. Manufacturers and Products:

1. Scheduled Manufacturer and Product:
  - a. Von Duprin 6000 Series
2. Acceptable Manufacturers and Products:
  - a. Folger Adam 300 Series
  - b. HES 1006 Series

### B. Requirements:

1. Provide electric strikes designed for use with type of locks shown at each opening.
2. Provide electric strikes UL Listed as burglary resistant that are tested to a minimum endurance test of 1,000,000 cycles.
3. Where required, provide electric strikes UL Listed for fire doors and frames.
4. Provide transformers and rectifiers for each strike as required. Verify voltage with electrical contractor.

## 2.15 POWER SUPPLIES

### A. Manufacturers and Products:

1. Scheduled Manufacturer and Product:
  - a. Schlage/Von Duprin PS900 Series
2. Acceptable Manufacturers and Products:
  - a. Precision ELR series
  - b. Securitron BPS series

### B. Requirements:

1. Provide power supplies approved by manufacturer of supplied electrified hardware.
2. Provide appropriate quantity of power supplies necessary for proper operation of electrified locking components as recommended by manufacturer of electrified locking components with consideration for each electrified component using power supply, location of power supply, and approved wiring diagrams. Locate power supplies as directed by Architect.
3. Provide regulated and filtered 24 VDC power supply, and UL class 2 listed.
4. Provide power supplies with the following features:

- a. 12/24 VDC Output, field selectable.
- b. Class 2 Rated power limited output.
- c. Universal 120-240 VAC input.
- d. Low voltage DC, regulated and filtered.
- e. Polarized connector for distribution boards.
- f. Fused primary input.
- g. AC input and DC output monitoring circuit w/LED indicators.
- h. Cover mounted AC Input indication.
- i. Tested and certified to meet UL294.
- j. NEMA 1 enclosure.
- k. Hinged cover w/lock down screws.
- l. High voltage protective cover.

## 2.16 CYLINDERS

### A. Manufacturers:

- 1. Scheduled Manufacturer and Product:
  - a. Falcon
- 2. Acceptable Manufacturers and Products:
  - a. Sargent
  - b. Best

### B. Requirements:

- 1. Provide cylinders/cores to match Owner's existing SCHLAGE key system, compliant with ANSI/BHMA A156.5; latest revision; cylinder face finished to match lockset, manufacturer's series as indicated. Refer to "KEYING" article, herein.
- 2. Provide cylinders in the below-listed configuration(s), distributed throughout the Project as indicated.
  - a. Cylinder/Core Type:
    - 1) Conventional
- 3. Construction Cylinders or Keying.
  - a. Provide temporary construction cylinders or construction keying as required.
    - 1) 3 construction control keys or extractor tools
    - 2) 12 construction change (day) keys.

## 2.17 KEYING

- A. Provide a factory registered keying system, complying with guidelines in ANSI/BHMA A156.28, incorporating decisions made at keying conference.

### B. Requirements:

- 1. Provide keying system capable of multiplex masterkeying.
- 2. Provide permanent cylinders keyed by the manufacturer according to the following key system.
  - a. Match Owner's existing Schlage key system.
  - b. Master Keying system as directed by the Owner.
  - c. (Great)Grand Master Key System: Cylinders/cores operated by change(day) keys and subsequent masters (including grand/great grand) keys.



3. Forward bitting list and keys separately from cylinders, by means as directed by Owner. Failure to comply with forwarding requirements will be cause for replacement of cylinders/cores involved at no additional cost to Owner.
4. Provide keys with the following features:
  - a. Material: Nickel silver; minimum thickness of .107-inch (2.3mm)
5. Identification:
  - a. Identification stamping provisions must be approved by the Architect and Owner.
  - b. Stamp keys with Owner's unique key system facility code as established by the manufacturer; key symbol and embossed or stamped with "DO NOT DUPLICATE".
6. Quantity: Furnish in the following quantities.
  - a. Change (Day) Keys: 3 per cylinder/core.
  - b. Permanent Control Keys: 3 (only applicable to interchangeable core).
  - c. Master Keys: 6/ea (per master).
  - d. Unused balance of key blanks shall be provided to Owner with cut keys.
7. Verify with Owner where permanent keys are to be shipped to.

## 2.18 KEY CONTROL SYSTEM

### A. Manufacturers:

1. Scheduled Manufacturer:
  - a. Telkee
2. Acceptable Manufacturers:
  - a. HPC
  - b. Lund

### B. Requirements:

1. Provide key control system, including envelopes, labels, tags with self-locking key clips, receipt forms, 3-way visible card index, temporary markers, permanent markers, and standard metal cabinet, all as recommended by system manufacturer, with capacity for 150% of number of locks required for Project.
  - a. Provide complete cross index system set up by hardware supplier, and place keys on markers and hooks in cabinet as determined by final key schedule.
  - b. Provide hinged-panel type cabinet for wall mounting.

## 2.19 DOOR CLOSERS

### A. Manufacturers and Products:

1. Scheduled Manufacturer and Product:
  - a. Falcon SC70A series
2. Acceptable Manufacturers and Products:
  - a. Sargent 351 series
  - b. Dorma 8900 series.

### B. Requirements:

1. Provide door closers conforming to ANSI/BHMA A156.4 Grade 1 requirements by BHMA certified independent testing laboratory. ISO 9000 certify closers. Stamp units with date of manufacture code.
2. Provide door closers with fully hydraulic, full rack and pinion action with aluminum cylinder.
3. Closer Body: 1-1/2-inch (38 mm) diameter with 5/8-inch (16 mm) diameter heat-treated pinion journal.
4. Hydraulic Fluid: Fireproof, passing requirements of UL10C, and requiring no seasonal closer adjustment for temperatures ranging from 120 degrees F to -30 degrees F.
5. Spring Power: Continuously adjustable over full range of closer sizes, and providing reduced opening force as required by accessibility codes and standards.
6. Hydraulic Regulation: By tamper-proof, non-critical valves, with separate adjustment for latch speed, general speed, and backcheck.
7. Pressure Relief Valve (PRV) Technology: Not permitted.
8. Provide special templates, drop plates, mounting brackets, or adapters for arms as required for details, overhead stops, and other door hardware items interfering with closer mounting.

## 2.20 DOOR CLOSERS

### A. Manufacturers and Products:

1. Scheduled Manufacturer and Product:
  - a. Falcon SC80A series
2. Acceptable Manufacturers and Products:
  - a. Sargent 1331 series
  - b. Dorma 8600 series

### B. Requirements:

1. Provide door closers conforming to ANSI/BHMA A156.4 Grade 1 requirements by BHMA certified independent testing laboratory.
2. Provide door closers with fully hydraulic, full rack and pinion action with aluminum cylinder.
3. Closer Body: 1-1/4-inch (32 mm) diameter, with 5/8-inch (16 mm) diameter heat-treated pinion journal.
4. Hydraulic Fluid: Fireproof, passing requirements of UL10C, and requiring no seasonal closer adjustment for temperatures ranging from 120 degrees F to -30 degrees F.
5. Spring Power: Continuously adjustable over full range of closer sizes, and providing reduced opening force as required by accessibility codes and standards.
6. Hydraulic Regulation: By tamper-proof, non-critical valves, with separate adjustment for latch speed, general speed, and backcheck.
7. Pressure Relief Valve (PRV) Technology: Not permitted.
8. Provide special templates, drop plates, mounting brackets, or adapters for arms as required for details, overhead stops, and other door hardware items interfering with closer mounting.

## 2.21 ELECTRO-MECHANICAL AUTOMATIC OPERATORS

### A. Manufacturers and Products:

1. Scheduled Manufacturer and Product:
  - a. Falcon 8000 series

2. Acceptable Manufacturers and Products:
    - a. Besam Swingmaster MP
    - b. Horton 4000LE series
- B. Requirements:
1. Provide low energy automatic operator units that are electro-mechanical design complying with ANSI/BHMA A156.19.
  2. Provide drop plates, brackets, and adapters for arms as required to suit details.
  3. Provide actuator switches for operation as specified. Provide weather-resistant actuators at exterior applications.
  4. Provide complete assemblies of controls, switches, power supplies, relays, and parts/material recommended and approved by manufacturer of automatic operator for each individual leaf. Actuators control both doors simultaneously at pairs. Sequence operation of exterior and vestibule doors with automatic operators to allow ingress or egress through both sets of openings as directed by Architect. Locate actuators, key switches, and other controls as directed by Architect.

## 2.22 DOOR TRIM

- A. Manufacturers:
1. Scheduled Manufacturer:
    - a. Ives
  2. Acceptable Manufacturers:
    - a. Trimco
    - b. Rockwood
    - c. Hager
- B. Requirements:
1. Provide push plates, push bars, pull plates, pulls, and hands-free reversible door pulls with diameter and length as scheduled.

## 2.23 PROTECTION PLATES

- A. Manufacturers:
1. Scheduled Manufacturer:
    - a. Ives
  2. Acceptable Manufacturers:
    - a. Trimco
    - b. Rockwood
    - c. Hager
- B. Requirements:
1. Provide protection plates with a minimum of 0.050 inch (1 mm) thick, beveled four edges as scheduled. Furnish with sheet metal or wood screws, finished to match plates.
  2. Sizes kick and armor plates 1 1/2 inches (51 mm) less width of door on single doors, and 1 inch (25 mm) less width of door on pairs. Adjust width at doors with mullions, edge guards, gasketing or other conflicting hardware.

3. Size mop plates 1" less width of door. Adjust width as needed for edge guards or other conflicting hardware.
4. At fire rated doors, provide protection plates over 16 inches high with UL label.

#### 2.24 OVERHEAD STOPS AND OVERHEAD STOP/HOLDERS

##### A. Manufacturers:

1. Scheduled Manufacturers:
  - a. Glynn-Johnson
2. Acceptable Manufacturers:
  - a. Rixson

##### B. Requirements:

1. Provide overhead stop at any door where conditions do not allow for a wall stop or floor stop presents tripping hazard.

#### 2.25 DOOR STOPS AND HOLDERS

##### A. Manufacturers:

1. Scheduled Manufacturer:
  - a. Ives
2. Acceptable Manufacturers:
  - a. Trimco
  - b. Rockwood

##### B. Provide door stops at each door leaf:

1. Provide wall stops wherever possible. Provide concave type where lockset has a push button or thumbturn.
2. Where a wall stop cannot be used, provide universal floor stops.
3. Where wall or floor stop cannot be used, provide overhead stop.
4. Provide roller bumper where doors open into each other and overhead stop cannot be used.

#### 2.26 THRESHOLDS, SEALS, DOOR SWEEPS, AUTOMATIC DOOR BOTTOMS, AND GASKETING

##### A. Manufacturers:

1. Scheduled Manufacturer:
  - a. Zero International
2. Acceptable Manufacturers:
  - a. National Guard
  - b. Reese
  - c. Pemko

##### B. Requirements:

1. Provide thresholds, weather-stripping, and gasketing systems as specified and per architectural details. Match finish of other items.
2. Smoke- and Draft-Control Door Assemblies: Where smoke- and draft-control door assemblies are required, provide door hardware that meets requirements of assemblies tested according to UL 1784 and installed in compliance with NFPA 105.
3. Provide door sweeps, seals, astragals, and auto door bottoms only of type where resilient or flexible seal strip is easily replaceable and readily available.
4. Size thresholds 1/2 inch (13 mm) high by 5 inches (127 mm) wide by door width unless otherwise specified in the hardware sets or detailed in the drawings.

## 2.27 SILENCERS

### A. Manufacturers:

1. Scheduled Manufacturer:
  - a. Ives
2. Acceptable Manufacturers:
  - a. Rockwood
  - b. Trimco

### B. Requirements:

1. Provide "push-in" type silencers for hollow metal or wood frames.
2. Provide one silencer per 30 inches (762 mm) of height on each single frame, and two for each pair frame.
3. Omit where gasketing is specified.

## 2.28 DOOR VIEWERS

### A. Manufacturers:

1. Scheduled Manufacturer:
  - a. Ives
2. Acceptable Manufacturers:
  - a. Burns
  - b. Rockwood

### B. Provide appropriate door viewer for door type and rating with minimum of 180-degree view area.

## 2.29 FINISHES

### A. Provide finish for each item as indicated in the sets.

## PART 3 - EXECUTION

### 3.01 EXAMINATION

- A. Prior to installation of hardware, examine doors and frames, with Installer present, for compliance with requirements for installation tolerances, labeled fire-rated door assembly construction, wall and floor construction, and other conditions affecting performance. Verify doors, frames, and walls have been properly reinforced for hardware installation.
- B. Examine roughing-in for electrical power systems to verify actual locations of wiring connections before electrified door hardware installation.
- C. Submit a list of deficiencies in writing and proceed with installation only after unsatisfactory conditions have been corrected.

### 3.02 INSTALLATION

- A. Mount door hardware units at heights to comply with the following, unless otherwise indicated or required to comply with governing regulations.
  - 1. Standard Steel Doors and Frames: ANSI/SDI A250.8.
  - 2. Custom Steel Doors and Frames: HMMA 831.
  - 3. Interior Architectural Wood Flush Doors: ANSI/WDMA I.S. 1A
  - 4. Installation Guide for Doors and Hardware: DHI TDH-007-20
- B. Install door hardware in accordance with NFPA 80, NFPA 101 and provide post-install inspection, testing as specified in section 1.03.E unless otherwise required to comply with governing regulations.
- C. Install each hardware item in compliance with manufacturer's instructions and recommendations, using only fasteners provided by manufacturer.
- D. Do not install surface mounted items until finishes have been completed on substrate. Protect all installed hardware during painting.
- E. Set units level, plumb and true to line and location. Adjust and reinforce attachment substrate as necessary for proper installation and operation.
- F. Drill and countersink units that are not factory prepared for anchorage fasteners. Space fasteners and anchors according to industry standards.
- G. Install operating parts so they move freely and smoothly without binding, sticking, or excessive clearance.
- H. Hinges: Install types and in quantities indicated in door hardware schedule but not fewer than quantity recommended by manufacturer for application indicated.
- I. Lock Cylinders:
  - 1. Install construction cylinders (or construction keying) to secure building and areas during construction period.
  - 2. Replace construction cylinders with permanent cylinders as indicated in keying section.
- J. Wiring: Coordinate with Division 26, ELECTRICAL and Division 28 ELECTRONIC SAFETY AND SECURITY sections for:
  - 1. Conduit, junction boxes and wire pulls.
  - 2. Connections to and from power supplies to electrified hardware.
  - 3. Connections to fire/smoke alarm system and smoke evacuation system.

4. Connection of wire to door position switches and wire runs to central room or area, as directed by Architect.
  5. Connections to panel interface modules, controllers, and gateways.
  6. Testing and labeling wires with Architect's opening number.
- K. Key Control System: Tag keys and place them on markers and hooks in key control system cabinet, as determined by final keying schedule.
- L. Door Closers: Mount closers on room side of corridor doors, inside of exterior doors, and stair side of stairway doors from corridors. Mount closers so they are not visible in corridors, lobbies and other public spaces unless approved by Architect.
- M. Closer/holders: Mount closer/holders on room side of corridor doors, inside of exterior doors, and stair side of stairway doors.
- N. Power Supplies: Locate power supplies as indicated or, if not indicated, above accessible ceilings or in equipment room, or alternate location as directed by Architect.
- O. Thresholds: Set thresholds in full bed of sealant complying with requirements specified in Division 07 Section "Joint Sealants."
- P. Stops: Provide floor stops for doors unless wall or other type stops are indicated in door hardware schedule. Do not mount floor stops where they may impede traffic or present tripping hazard.
- Q. Perimeter Gasketing: Apply to head and jamb, forming seal between door and frame.
- R. Meeting Stile Gasketing: Fasten to meeting stiles, forming seal when doors are closed.
- S. Door Bottoms and Sweeps: Apply to bottom of door, forming seal with threshold when door is closed.

### 3.03 ADJUSTING

- A. Initial Adjustment: Adjust and check each operating item of door hardware and each door to ensure proper operation or function of every unit. Replace units that cannot be adjusted to operate as intended. Adjust door control devices to compensate for final operation of heating and ventilating equipment and to comply with referenced accessibility requirements.
1. Electric Strikes: Adjust horizontal and vertical alignment of keeper to properly engage lock bolt.
  2. Spring Hinges: Adjust to achieve positive latching when door can close freely from an open position of 30 degrees.
  3. Door Closers: Adjust sweep period to comply with accessibility requirements and requirements of authorities having jurisdiction.
- B. Occupancy Adjustment: Approximately three to six months after date of Substantial Completion, examine and readjust each item of door hardware, including adjusting operating forces, as necessary to ensure function of doors and door hardware.

### 3.04 CLEANING AND PROTECTION

- A. Clean adjacent surfaces soiled by door hardware installation.

- B. Clean operating items per manufacturer's instructions to restore proper function and finish.
- C. Provide final protection and maintain conditions that ensure door hardware is without damage or deterioration at time of Substantial Completion.

3.05 DOOR HARDWARE SCHEDULE

- A. The intent of the hardware specification is to specify the hardware for interior and exterior doors, and to establish a type, continuity, and standard of quality. However, it is the door hardware supplier's responsibility to thoroughly review existing conditions, schedules, specifications, drawings, and other Contract Documents to verify the suitability of the hardware specified.
- B. Discrepancies, conflicting hardware, and missing items are to be brought to the attention of the architect with corrections made prior to the bidding process. Omitted items not included in a hardware set should be scheduled with the appropriate additional hardware required for proper application.
- C. Hardware items are referenced in the following hardware schedule. Refer to the above specifications for special features, options, cylinders/keying, and other requirements.
- D. Hardware Sets:

104149 OPT0353135 Version 4

HARDWARE GROUP NO. 01

For use on Door #(s):  
H101A

Provide each OPENING with the following:

QTY		DESCRIPTION	CATALOG NUMBER	FINISH	MFR
1	EA	CONT. HINGE	112XY	628	IVE
1	EA	DUMMY PUSH BAR	250DT	626	FAL
1	EA	90 DEG OFFSET PULL	8190EZHD 10" O	630-316	IVE
1	EA	OH STOP	90S	630	GLY
1	EA	AUTO OPERATOR	8242 MS 120 VAC (DROP MOUNT TO ALLOW FOR OH STOP)	689	FAL
1	EA	ACTUATOR	8310-853T	630	LCN
1	EA	MOUNT BOX	8310-867S		LCN
1	EA	ACTUATOR	SHARED WITH ADJACENT OPENING (VESTIBULE)		

BOTH AUTO OPERATOR ACTUATORS ENABLED AT ALL TIMES. PUSHING EITHER ACTUATOR SIGNALS AUTO OPERATOR TO OPEN DOOR. FREE EGRESS AT ALL TIMES.



HARDWARE GROUP NO. 02

For use on Door #(s):  
H117

Provide each OPENING with the following:

QTY		DESCRIPTION	CATALOG NUMBER	FINISH	MFR
3	EA	HINGE	5BB1HW SIZE, QTY, NRP AS REQ'D (SEE SPECS)	652	IVE
1	EA	PRIVACY LOCK	MA311 OCCUPIED/VACANT DGM	626	FAL
1	EA	SURFACE CLOSER	SC81A RW/PA	689	FAL
1	EA	KICK PLATE	8400 10" X 1 1/2" LDW B-CS	630	IVE
1	EA	MOP PLATE	8400 4" X 1" LDW B-CS	630	IVE
1	EA	WALL STOP	WS406/407CCV	630	IVE
1	EA	GASKETING	488SBK PSA	BK	ZER

HARDWARE GROUP NO. 03

For use on Door #(s):  
H105B

Provide each OPENING with the following:

QTY		DESCRIPTION	CATALOG NUMBER	FINISH	MFR
3	EA	HINGE	5BB1HW 4.5 X 4.5 NRP	630	IVE
1	EA	ENTRY / OFFICE LOCK	T511P DAN	626	FAL
1	EA	SURFACE CLOSER	SC71A SS	689	FAL
1	EA	KICK PLATE	8400 10" X 1 1/2" LDW B-CS	630	IVE
1	EA	RAIN DRIP	142AA	AA	ZER
1	SET	WEATHERSTRIPPING	429AA-S	AA	ZER
1	EA	DOOR SWEEP, BRUSH W/ DRIP	8198AA	AA	ZER
1	EA	THRESHOLD, 1/2"	655A	A	ZER

HARDWARE GROUP NO. 04

For use on Door #(s):  
H102 H106

Provide each OPENING with the following:

QTY		DESCRIPTION	CATALOG NUMBER	FINISH	MFR
3	EA	HINGE	5BB1HW SIZE, QTY, NRP AS REQ'D (SEE SPECS)	652	IVE
1	EA	ENTRY / OFFICE LOCK	W511P6 DAN	626	FAL
1	EA	SURFACE CLOSER	SC81A RW/PA	689	FAL
1	EA	KICK PLATE	8400 10" X 1 1/2" LDW B-CS	630	IVE
1	EA	WALL STOP	WS406/407CCV	630	IVE
1	EA	GASKETING	488SBK PSA	BK	ZER

HARDWARE GROUP NO. 05

For use on Door #(s):

H105A            H118                    H202                    H302                    H305

Provide each OPENING with the following:

QTY		DESCRIPTION	CATALOG NUMBER	FINISH	MFR
3	EA	HINGE	5BB1HW SIZE, QTY, NRP AS REQ'D (SEE SPECS)	652	IVE
1	EA	CLASSROOM LOCK	W561P6 DAN	626	FAL
1	EA	SURFACE CLOSER	SC81A RW/PA	689	FAL
1	EA	KICK PLATE	8400 10" X 1 1/2" LDW B-CS	630	IVE
1	EA	WALL STOP	WS406/407CCV	630	IVE
1	EA	GASKETING	488SBK PSA	BK	ZER

HARDWARE GROUP NO. 06

For use on Door #(s):

H119

Provide each OPENING with the following:

QTY		DESCRIPTION	CATALOG NUMBER	FINISH	MFR
3	EA	HINGE	5BB1HW 4.5 X 4.5 NRP	630	IVE
1	EA	STOREROOM LOCK	T581P DAN	626	FAL
1	EA	SURFACE CLOSER	SC71A SS	689	FAL
1	EA	KICK PLATE	8400 10" X 1 1/2" LDW B-CS	630	IVE
1	EA	RAIN DRIP	142AA	AA	ZER
1	SET	WEATHERSTRIPPING	429AA-S	AA	ZER
1	EA	DOOR SWEEP, BRUSH W/ DRIP	8198AA	AA	ZER
1	EA	THRESHOLD, 1/2"	655A	A	ZER

HARDWARE GROUP NO. 07

For use on Door #(s):

H114            H115                    H113                    H204                    H205                    H304

Provide each OPENING with the following:

QTY		DESCRIPTION	CATALOG NUMBER	FINISH	MFR
3	EA	HINGE	5BB1 SIZE, QTY, NRP AS REQ'D (SEE SPECS)	652	IVE
1	EA	STOREROOM LOCK	W581P6 DAN	626	FAL
1	EA	SURFACE CLOSER	SC81A RW/PA	689	FAL
1	EA	KICK PLATE	8400 10" X 1 1/2" LDW B-CS	630	IVE
1	EA	WALL STOP	WS406/407CCV	630	IVE
1	EA	GASKETING	488SBK PSA	BK	ZER

HARDWARE GROUP NO. 08

For use on Door #(s):

H101B            H120

Provide each OPENING with the following:

QTY		DESCRIPTION	CATALOG NUMBER	FINISH	MFR
3	EA	HINGE	5BB1HW 4.5 X 4.5 NRP	630	IVE
1	EA	PANIC HARDWARE	25-R-NL	626	FAL
1	EA	MORTISE CYLINDER	986	626	FAL
1	EA	ELECTRIC STRIKE	6300 FSE	630	VON
1	EA	SURFACE CLOSER	SC71A SS	689	FAL
1	EA	KICK PLATE	8400 10" X 1 1/2" LDW B-CS	630	IVE
1	EA	RAIN DRIP	142AA	AA	ZER
1	SET	WEATHERSTRIPPING	429AA-S	AA	ZER
1	EA	DOOR SWEEP, BRUSH W/ DRIP	8198AA	AA	ZER
1	EA	THRESHOLD, 1/2"	655A	A	ZER
1	EA	CREDENTIAL READER	BY ACCESS CONTROL INTEGRATOR		B/O
1	EA	POWER SUPPLY	PS902 120/240 VAC	LGR	SCE

DOOR NORMALLY CLOSED AND LOCKED. PRESENTING VALID CREDENTIAL TO READER  
MOMENTARILY RELEASES ELECTRIC STRIKE, ALLOWING ACCESS. DOOR TO REMAIN LOCKED  
UPON LOSS OF POWER. FREE EGRESS AT ALL TIMES.

HARDWARE GROUP NO. 09

For use on Door #(s):  
H100

Provide each OPENING with the following:

QTY		DESCRIPTION	CATALOG NUMBER	FINISH	MFR
1	EA	CONT. HINGE	112XY EPT	628	IVE
1	EA	POWER TRANSFER	EPT10	689	VON
1	EA	ELEC PANIC HARDWARE	LM-MEL-25-R-NL-OP 24 VDC	626	FAL
1	EA	RIM CYLINDER	951	626	FAL
1	EA	90 DEG OFFSET PULL	8190EZHD 10" O	630-316	IVE
1	EA	OH STOP	90S	630	GLY
1	EA	AUTO OPERATOR	8242 MS 120 VAC (DROP MOUNT TO ALLOW FOR OH STOP)	689	FAL
1	EA	WEATHER RING	8310-801		LCN
1	EA	ACTUATOR	8310-853T (EXTERIOR, COLUMN MOUNTED)	630	LCN
1	EA	DUAL ACTUATOR	8310-855 (VESTIBULE, WALL MOUNTED)	630	LCN
2	EA	MOUNT BOX	8310-867S		LCN
1	EA	WEATHERSTRIPPING	BY DOOR/FRAME MANUFACTURER		B/O
1	EA	DOOR SWEEP, BRUSH W/ DRIP	8198AA	AA	ZER
1	EA	THRESHOLD, 1/2"	655A	A	ZER
1	EA	CREDENTIAL READER	BY ACCESS CONTROL INTEGRATOR		B/O
1	EA	POWER SUPPLY	PS902 900-4RL 120/240 VAC	LGR	SCE

DOOR(S) NORMALLY CLOSED AND LOCKED AND EXTERIOR ACTUATOR DISABLED. PRESENTING VALID CREDENTIAL TO READER RETRACTS EXIT DEVICE LATCH AND ENABLES EXTERIOR ACTUATOR. PUSHING ENABLED EXTERIOR ACTUATOR SIGNALS AUTOMATIC OPERATOR TO OPEN DOOR. INTERIOR ACTUATOR ENABLED AT ALL TIMES. PUSHING INTERIOR ACTUATOR RETRACTS LATCH AND SIGNALS AUTOMATIC OPERATOR TO OPEN DOOR. EXIT DEVICE LATCH ALSO CAPABLE OF BEING ELECTRONICALLY DOGGED DOWN (I.E. PUSH/PULL MODE) AS DESIGNATED BY ACCESS CONTROL SYSTEM SCHEDULE. EXIT DEVICE LATCHES AND LOCKS WITH LOSS OF POWER. FREE EGRESS AT ALL TIMES.

HARDWARE GROUP NO. 10

For use on Door #(s):

H103            H111            H203            H211            H303            H311

Provide each OPENING with the following:

QTY		DESCRIPTION	CATALOG NUMBER	FINISH	MFR
3	EA	HINGE	5BB1HW SIZE, QTY, NRP AS REQ'D (SEE SPECS)	652	IVE
1	EA	FIRE EXIT HARDWARE	F-19-R-L-BE-DANE	689	FAL
1	EA	SURFACE CLOSER	SC81A RW/PA	689	FAL
1	EA	KICK PLATE	8400 10" X 1 1/2" LDW B-CS	630	IVE
1	EA	WALL STOP	WS406/407CCV	630	IVE
1	EA	GASKETING	488SBK PSA	BK	ZER

HARDWARE GROUP NO. 11

For use on Door #(s):

H1            H2            H3            H4            H5            H6  
H10            H11            H12            H13            H14            H15  
H16            H18            H17            H21            H22            H23  
H24            H25            H26            H27            H28            H20

Provide each OPENING with the following:

QTY		DESCRIPTION	CATALOG NUMBER	FINISH	MFR
2	EA	SPRING HINGE	3SP1 4.5 X 4.5	652	IVE
1	EA	HINGE	5BB1 SIZE, QTY, NRP AS REQ'D (SEE SPECS)	652	IVE
1	EA	PASSAGE SET	J10F MAR 16-059	626	SCH
1	EA	SGL CYL DEADBOLT	B60N6 12-321 10-116	626	SCH
1	EA	KICK PLATE	8400 10" X 1 1/2" LDW B-CS	630	IVE
1	EA	DOOR STOP	73 OR 060 (AS REQ'D)	Z-625E	IVE
1	EA	GASKETING	488SBK PSA	BK	ZER
1	EA	DOOR BOTTOM	253A	A	ZER
1	EA	THRESHOLD	BY OTHERS		B/O
1	EA	VIEWER, 190 DEG	U698	626	IVE

HARDWARE GROUP NO. 12

For use on Door #(s):

U5            U7            U13            U16

Provide each OPENING with the following:

QTY		DESCRIPTION	CATALOG NUMBER	FINISH	MFR
3	EA	HINGE	5BB1 SIZE, QTY, NRP AS REQ'D (SEE SPECS)	652	IVE
1	EA	PRIVACY LOCK	J40 MAR	626	SCH
1	EA	DOOR STOP	73 OR 060 (AS REQ'D)	Z-625E	IVE
3	EA	SILENCER	SR SERIES (AS REQ'D FOR WDF/HMF)	GRY	IVE

HARDWARE GROUP NO. 13

For use on Door #(s):

U3                    U11                    U4                    U12

Provide each OPENING with the following:

QTY		DESCRIPTION	CATALOG NUMBER	FINISH	MFR
3	EA	HINGE	5BB1 SIZE, QTY, NRP AS REQ'D (SEE SPECS)	652	IVE
1	EA	PASSAGE SET	J10 MAR	626	SCH
1	EA	DOOR STOP	73 OR 060 (AS REQ'D)	Z-625E	IVE
3	EA	SILENCER	SR SERIES (AS REQ'D FOR WDF/HMF)	GRY	IVE

HARDWARE GROUP NO. 14

For use on Door #(s):

U6                    U14

Provide each OPENING with the following:

QTY		DESCRIPTION	CATALOG NUMBER	FINISH	MFR
3	EA	HINGE	5BB1 SIZE, QTY, NRP AS REQ'D (SEE SPECS)	652	IVE
1	EA	ENTRANCE LOCK	J54 MAR	626	SCH
1	EA	DOOR STOP	73 OR 060 (AS REQ'D)	Z-625E	IVE
3	EA	SILENCER	SR SERIES (AS REQ'D FOR WDF/HMF)	GRY	IVE

END OF SECTION

**SECTION 088000  
GLAZING**

**PART 1 GENERAL**

**1.01 SECTION INCLUDES**

- A. Insulating glass units.
- B. Glazing units.
- C. Plastic films.
- D. Glazing compounds.

**1.02 RELATED REQUIREMENTS**

- A. Section 079200 - Joint Sealants: Sealants for other than glazing purposes.
- B. Section 081113 - Hollow Metal Doors and Frames: Glazed lites in doors and borrowed lites.
- C. Section 081416 - Flush Wood Doors: Glazed lites in doors.
- D. Section 084313 - Aluminum-Framed Storefronts: Glazing provided as part of storefront assembly.
- E. Section 085413 - Fiberglass Windows: Glazing provided by window manufacturer.

**1.03 REFERENCE STANDARDS**

- A. 16 CFR 1201 - Safety Standard for Architectural Glazing Materials; Current Edition.
- B. ANSI Z97.1 - American National Standard for Safety Glazing Materials Used in Buildings - Safety Performance Specifications and Methods of Test; 2015 (Reaffirmed 2020).
- C. ASCE 7 - Minimum Design Loads and Associated Criteria for Buildings and Other Structures; Most Recent Edition Cited by Referring Code or Reference Standard.
- D. ASTM C864 - Standard Specification for Dense Elastomeric Compression Seal Gaskets, Setting Blocks, and Spacers; 2005 (Reapproved 2019).
- E. ASTM C920 - Standard Specification for Elastomeric Joint Sealants; 2018.
- F. ASTM C1036 - Standard Specification for Flat Glass; 2021.
- G. ASTM C1048 - Standard Specification for Heat-Strengthened and Fully Tempered Flat Glass; 2018.
- H. ASTM C1172 - Standard Specification for Laminated Architectural Flat Glass; 2019.
- I. ASTM C1193 - Standard Guide for Use of Joint Sealants; 2016 (Reapproved 2023).
- J. ASTM C1376 - Standard Specification for Pyrolytic and Vacuum Deposition Coatings on Flat Glass; 2021a.
- K. ASTM E1300 - Standard Practice for Determining Load Resistance of Glass in Buildings; 2016.
- L. ASTM E2190 - Standard Specification for Insulating Glass Unit Performance and Evaluation; 2019.
- M. GANA (GM) - GANA Glazing Manual; 2022.
- N. GANA (SM) - GANA Sealant Manual; 2008.
- O. GANA (LGRM) - Laminated Glazing Reference Manual; 2019.
- P. ICC (IBC) - International Building Code; Most Recent Edition Adopted by Authority Having Jurisdiction, Including All Applicable Amendments and Supplements.
- Q. IGMA TM-3000 - North American Glazing Guidelines for Sealed Insulating Glass Units for Commercial & Residential Use; 1990 (2016).
- R. NFRC 100 - Procedure for Determining Fenestration Product U-factors; 2023.
- S. NFRC 200 - Procedure for Determining Fenestration Product Solar Heat Gain Coefficient and Visible Transmittance at Normal Incidence; 2023.

- T. NFRC 300 - Test Method for Determining the Solar Optical Properties of Glazing Materials and Systems; 2023.

#### 1.04 SUBMITTALS

- A. See Section 013000 - Administrative Requirements for submittal procedures.
- B. Product Data on Insulating Glass Unit and Glazing Unit Glazing Types: Provide structural, physical and environmental characteristics, size limitations, special handling and installation requirements.
- C. Product Data on Glazing Compounds and Accessories: Provide chemical, functional, and environmental characteristics, limitations, special application requirements, and identify available colors.
- D. Samples: Submit two samples 12 by 12 inch (\_\_\_ by \_\_\_ mm) in size of glass units.
- E. Certificate: Certify that products of this section meet or exceed specified requirements.
- F. Manufacturer's qualification statement.

#### 1.05 QUALITY ASSURANCE

- A. Perform Work in accordance with GANA (GM), GANA (SM), GANA (LGRM), and IGMA TM-3000 for glazing installation methods. Maintain one copy on site.
- B. Manufacturer Qualifications: Company specializing in manufacturing the products specified in this section with minimum three years of documented experience.
  - 1. Provide certified glass products through ANSI accredited certifications that include plant audits and independent laboratory performance testing.
- C. Installer Qualifications: Company specializing in performing work of the type specified and with at least three years documented experience.
  - 1. Provide company, field supervisors, and installers that hold active ANSI accredited certifications in appropriate categories for work specified.

#### 1.06 FIELD CONDITIONS

- A. Do not install glazing when ambient temperature is less than 50 degrees F (10 degrees C).
- B. Maintain minimum ambient temperature before, during and 24 hours after installation of glazing compounds.

#### 1.07 WARRANTY

- A. See Section 017800 - Closeout Submittals for additional warranty requirements.

### PART 2 PRODUCTS

#### 2.01 MANUFACTURERS

- A. Float Glass Manufacturers:
  - 1. Guardian Glass, LLC: [www.guardianglass.com/#sle](http://www.guardianglass.com/#sle).
  - 2. Pilkington North America Inc: [www.pilkington.com/na/#sle](http://www.pilkington.com/na/#sle).
  - 3. Vitro Architectural Glass (formerly PPG Glass): [www.vitroglazings.com/#sle](http://www.vitroglazings.com/#sle).
  - 4. Substitutions: See Section 016000 - Product Requirements.
- B. Fire-Rated Glass Manufacturers:
  - 1. Technical Glass Products (TGP): [www.fireglass.com/#sle](http://www.fireglass.com/#sle)
    - a. Contact: Saira Seldo, SAFTI/FIRST / O'Keeffe's, Inc.; 888.653.333 Ext. 788; [SairaS@safti.com](mailto:SairaS@safti.com)
  - 2. Substitutions: See Section 016000 - Product Requirements.

#### 2.02 PERFORMANCE REQUIREMENTS - EXTERIOR GLAZING ASSEMBLIES

- A. Provide type and thickness of exterior glazing assemblies to support assembly dead loads, and to withstand live loads caused by positive and negative wind pressure acting normal to plane of glass.
  - 1. Comply with ASTM E1300 for design load resistance of glass type, thickness, dimensions, and maximum lateral deflection of supported glass.



2. Provide glass edge support system sufficiently stiff to limit the lateral deflection of supported glass edges to less than 1/175 of their lengths under specified design load.
  3. Glass thicknesses listed are minimum.
- B. Weather-Resistive Barrier Seals: Provide completed assemblies that maintain continuity of building enclosure water-resistive barrier, vapor retarder, and/or air barrier.
1. In conjunction with weather barrier related materials described in other sections, as follows:
- C. Thermal and Optical Performance: Provide exterior glazing products with performance properties as indicated. Performance properties are in accordance with manufacturer's published data as determined with the following procedures and/or test methods:
1. Center of Glass U-Value: Comply with NFRC 100 using Lawrence Berkeley National Laboratory (LBNL) WINDOW 6.3 computer program.
  2. Center of Glass Solar Heat Gain Coefficient (SHGC): Comply with NFRC 200 using Lawrence Berkeley National Laboratory (LBNL) WINDOW 6.3 computer program.
  3. Solar Optical Properties: Comply with NFRC 300 test method.

### 2.03 GLASS MATERIALS

- A. Float Glass: Provide float glass based glazing unless otherwise indicated.
1. Annealed Type: ASTM C1036, Type I - Transparent Flat, Class 1 - Clear, Quality - Q3.
  2. Kind HS - Heat-Strengthened Type: Complies with ASTM C1048.
  3. Kind FT - Fully Tempered Type: Complies with ASTM C1048.
  4. Fully Tempered Safety Glass: Complies with ANSI Z97.1 or 16 CFR 1201 criteria for safety glazing used in hazardous locations.
  5. Thicknesses: As indicated; provide greater thickness as required for exterior glazing wind load design.

### 2.04 SEALED INSULATING GLASS UNITS

- A. Manufacturers:
1. Glass: Any of the manufacturers specified for float glass.
  2. Substitutions: See Section 016000 - Product Requirements.
- B. Insulating Glass Units: Types as indicated.
1. Durability: Certified by an independent testing agency to comply with ASTM E2190.
  2. Coated Glass: Comply with requirements of ASTM C1376 for pyrolytic (hard-coat) or magnetic sputter vapor deposition (soft-coat) type coatings on flat glass; coated vision glass, Kind CV.
  3. Metal-Edge Spacers: Aluminum, bent and soldered corners.
  4. Spacer Color: Black.
  5. Edge Seal: Glass to elastomer with supplementary silicone sealant.
    - a. Color: Black.
  6. Purge interpane space with dry air, hermetically sealed.
- C. Type IG-1 - Insulating Glass Units: Vision glass, double glazed.
1. Applications: Exterior glazing unless otherwise indicated.
  2. Space between lites filled with air.
  3. Outboard Lite: Fully tempered float glass, 1/4 inch (6.4 mm) thick, minimum.
    - a. Tint: Clear.
    - b. Coating: Low-E (passive type), on #2 surface.
  4. Metal edge spacer.
  5. Inboard Lite: Fully tempered float glass, 1/4 inch (6.4 mm) thick, minimum.
    - a. Tint: Clear.
  6. Total Thickness: 1 inch (25.4 mm).
  7. Thermal Transmittance (U-Value), Summer - Center of Glass: 0.28, nominal.
  8. Thermal Transmittance (U-Value), Winter - Center of Glass: 0.29, nominal.
  9. Visible Light Transmittance (VLT): 68 percent, nominal.
  10. Shading Coefficient: 0.43, nominal.

11. Solar Heat Gain Coefficient (SHGC): 0.38, nominal.

## **2.05 GLAZING UNITS**

- A. Type G-2 - Monolithic Interior Vision Glazing:
  1. Applications: Interior glazing unless otherwise indicated.
  2. Glass Type: Fully tempered float glass.
  3. Tint: Clear.
  4. Thickness: 1/4 inch (6.4 mm), nominal.

## **2.06 GLAZING COMPOUNDS**

- A. Type GC-2 - Butyl Sealant: Single component; ASTM C920 Grade NS, Class 12-1/2, Uses M and A, Shore A hardness of 10 to 20; black color.
- B. Type GC-5 - Silicone Sealant: Single component; neutral curing; capable of water immersion without loss of properties; nonbleeding, nonstaining; ASTM C920 Type S, Grade NS, Class 25, Uses M, A, and G; with cured Shore A hardness range of 15 to 25; Match frame color.
- C. Manufacturers:
  1. Bostik Inc: [www.bostik-us.com/#sle](http://www.bostik-us.com/#sle).
  2. Dow Corning Corporation: [www.dowcorning.com/construction/#sle](http://www.dowcorning.com/construction/#sle). Dow Corning Corporation: [www.dowcorning.com/construction/#sle](http://www.dowcorning.com/construction/#sle).
  3. Momentive Performance Materials, Inc: [www.momentive.com/#sle](http://www.momentive.com/#sle).
  4. Pecora Corporation: [www.pecora.com/#sle](http://www.pecora.com/#sle).
  5. Substitutions: See Section 016000 - Product Requirements.

## **2.07 GLAZING ACCESSORIES**

- A. Setting Blocks: Elastomeric material recommended by glass manufacturer, with 80 to 90 Shore A durometer hardness; ASTM C864 Option II. Length of 0.1 inch for each square foot (25 mm for each square meter) of glazing or minimum 4 inch (100 mm) by width of glazing rabbet space minus 1/16 inch (1.5 mm) by height to suit glazing method and pane weight and area.
- B. Spacer Shims: Elastomeric material recommended by glass manufacturer, 50 to 60 Shore A durometer hardness; ASTM C864 Option II. Minimum 3 inch (75 mm) long by one half the height of the glazing stop by thickness to suit application, self adhesive on one face.
- C. Glazing Tape, Back Bedding Mastic Type: Preformed, butyl-based, 100 percent solids compound with integral resilient spacer rod applicable to application indicated; 5 to 30 cured Shore A durometer hardness; coiled on release paper; black color.
- D. Glazing Splines: Resilient silicone extruded shape to suit glazing channel retaining slot; ASTM C864 Option II; color black.
- E. Glazing Clips: Manufacturer's standard type.

## **PART 3 EXECUTION**

### **3.01 VERIFICATION OF CONDITIONS**

- A. Verify that openings for glazing are correctly sized and within tolerances, including those for size, squareness, and offsets at corners.
- B. Verify that surfaces of glazing channels or recesses are clean, free of obstructions that may impede moisture movement, weeps are clear, and support framing is ready to receive glazing system.

### **3.02 PREPARATION**

- A. Clean contact surfaces with appropriate solvent and wipe dry within maximum of 24 hours before glazing. Remove coatings that are not tightly bonded to substrates.
- B. Seal porous glazing channels or recesses with substrate compatible primer or sealer.
- C. Prime surfaces scheduled to receive sealant where required for proper sealant adhesion.

### **3.03 INSTALLATION, GENERAL**

- A. Install glazing sealants in accordance with ASTM C1193, GANA (SM), and manufacturer's instructions.
- B. Do not exceed edge pressures around perimeter of glass lites as stipulated by glass manufacturer.

### **3.04 INSTALLATION - DRY GLAZING METHOD (GASKET GLAZING)**

- A. Application - Exterior and/or Interior Glazed: Set glazing infills from either the exterior or the interior of the building.
- B. Place setting blocks at 1/4 points with edge block no more than 6 inch (152 mm) from corners.
- C. Rest glazing on setting blocks and push against fixed stop with sufficient pressure on gasket to attain full contact.
- D. Install removable stops without displacing glazing gasket; exert pressure for full continuous contact.

### **3.05 INSTALLATION - WET GLAZING METHOD (SEALANT AND SEALANT)**

- A. Application - Exterior Glazed: Set glazing infills from the exterior of the building.
- B. Place setting blocks at 1/4 points and install glazing pane or unit.
- C. Install removable stops with glazing centered in space by inserting spacer shims both sides at 24 inch (610 mm) intervals, 1/4 inch (6.4 mm) below sight line.
- D. Fill gaps between glazing and stops with butyl type sealant to depth of bite on glazing, but not more than 3/8 inch (9 mm) below sight line to ensure full contact with glazing and continue the air and vapor seal.
- E. Apply sealant to uniform line, flush with sight line. Tool or wipe sealant surface smooth.

### **3.06 INSTALLATION - WET GLAZING METHOD (COMPOUND AND COMPOUND)**

- A. Application - Interior Glazed: Set glazing infills from the interior of the building.
- B. Install glazing resting on setting blocks. Install applied stop and center pane by use of spacer shims at 24 inch (610 mm) centers, kept 1/4 inch (6 mm) below sight line.
- C. Locate and secure glazing pane using glazers' clips.
- D. Fill gaps between glazing and stops with glazing compound until flush with sight line. Tool surface to straight line.

### **3.07 INSTALLATION - WET/DRY GLAZING METHOD (PREFORMED TAPE AND SEALANT)**

- A. Application - Exterior Glazed: Set glazing infills from the exterior of the building.
- B. Cut glazing tape to length and set against permanent stops, 3/16 inch (5 mm) below sight line. Seal corners by butting tape and dabbing with butyl sealant.
- C. Apply heel bead of butyl sealant along intersection of permanent stop with frame ensuring full perimeter seal between glass and frame to complete the continuity of the air and vapor seal.
- D. Place setting blocks at 1/4 points with edge block no more than 6 inch (152 mm) from corners.
- E. Rest glazing on setting blocks and push against tape and heel bead of sealant with sufficient pressure to attain full contact at perimeter of pane or glass unit.
- F. Install removable stops, with spacer strips inserted between glazing and applied stops 1/4 inch (6.4 mm) below sight lines.
  - 1. Place glazing tape on glazing pane of unit with tape flush with sight line.
- G. Fill gap between glazing and stop with butyl type sealant to depth equal to bite of frame on glazing, but not more than 3/8 inch (9 mm) below sight line.
- H. Apply cap bead of butyl type sealant along void between the stop and the glazing, to uniform line, flush with sight line. Tool or wipe sealant surface smooth.

### **3.08 INSTALLATION - WET/DRY GLAZING METHOD (TAPE AND SEALANT)**

- A. Application - Interior Glazed: Set glazing infills from the interior of the building.
- B. Cut glazing tape to length and install against permanent stops, projecting 1/16 inch (1.6 mm) above sight line.
- C. Place setting blocks at 1/4 points with edge block no more than 6 inch (152 mm) from corners.
- D. Rest glazing on setting blocks and push against tape to ensure full contact at perimeter of pane or unit.
- E. Install removable stops, spacer shims inserted between glazing and applied stops at 24 inch (610 mm) intervals, 1/4 inch (6 mm) below sight line.
- F. Fill gaps between pane and applied stop with butyl type sealant to depth equal to bite on glazing, to uniform and level line.
- G. Carefully trim protruding tape with knife.

### **3.09 INSTALLATION - BUTT JOINT GLAZING METHOD (SEALANT ONLY)**

- A. Application - Exterior Glazed: Set glazing infills from exterior side of building.
- B. Temporarily brace glass in position for duration of glazing process; mask edges of glass at adjoining glass edges and between glass edges and framing members.
- C. Temporarily secure a small diameter nonadhering foamed rod on back side of joint.
- D. Apply sealant to open side of joint in continuous operation; thoroughly fill joint without displacing foam rod, and then tool sealant surface smooth to concave profile.
- E. Permit sealant to cure then remove foam backer rod, and then apply sealant to opposite side, tool smooth to concave profile.
- F. Remove masking tape.

### **3.10 CLEANING**

- A. Remove excess glazing materials from finish surfaces immediately after application using solvents or cleaners recommended by manufacturers.
- B. Remove nonpermanent labels immediately after glazing installation is complete.
- C. Clean glass and adjacent surfaces after sealants are fully cured.
- D. Clean glass on both exposed surfaces not more than 4 days prior to Date of Substantial Completion in accordance with glass manufacturer's written recommendations.

### **3.11 PROTECTION**

- A. After installation, mark pane with an 'X' by using removable plastic tape or paste; do not mark heat absorbing or reflective glass units.
- B. Remove and replace glass that is damaged during construction period prior to Date of Substantial Completion.

**END OF SECTION**

**SECTION 088300  
MIRRORS**

**PART 1 GENERAL**

**1.01 SECTION INCLUDES**

- A. Gym Mirrors

**1.02 RELATED REQUIREMENTS**

- A. Section 102800 - Toilet, Bath, and Laundry Accessories: Metal mirror frames.

**1.03 SUBMITTALS**

- A. See Section 013000 - Administrative Requirements, for submittal procedures.
- B. Product Data on Mirror Types: Submit structural, physical and environmental characteristics, size limitations, special handling and installation requirements.
- C. Warranty: Submit manufacturer warranty and ensure that forms have been completed in Owner's name and registered with manufacturer.

**1.04 QUALITY ASSURANCE**

- A. Fabricate, store, transport, receive, install, and clean mirrors in accordance with manufacturer's recommendations.

**1.05 FIELD CONDITIONS**

- A. Do not install mirrors when ambient temperature is less than 50 degrees F (10 degrees C).
- B. Maintain minimum ambient temperature before, during and 24 hours after installation of glazing compounds.

**1.06 WARRANTY**

- A. See Section 017800 - Closeout Submittals, for additional warranty requirements.

**PART 2 PRODUCTS**

**2.01 MANUFACTURERS**

- A. Exercise Room Mirrors:
  - 1. City Glass Specialty Inc: [www.cityglassspecialty.com/#sle](http://www.cityglassspecialty.com/#sle).
  - 2. O'Neil's Glass: [www.oneilsglass.com/#sle](http://www.oneilsglass.com/#sle).
  - 3. Dulles Glass: [www.dullesglass.com/#sle](http://www.dullesglass.com/#sle).
  - 4. The Mirror Company; [www.themirrorcompany.com/#sle](http://www.themirrorcompany.com/#sle).

**2.02 MATERIALS**

- A. Gym Mirror: Clear, annealed glass, with protective overcoating.
  - 1. Material: Clear Mirror
  - 2. Shape: Rectangle
  - 3. Thickness: 1/4 inch (6.4 mm).
  - 4. Edges: flat polished.
  - 5. Corners: Eased
  - 6. Backing: Safety Backing
  - 7. Size: 36" wide by 72" high
  - 8. Quantity: (5) mirrors

**2.03 ACCESSORIES**

- A. Mirror Clips, J Bar, Screws for J Bar

**PART 3 EXECUTION**

**3.01 EXAMINATION**

- A. Verify that surfaces of mirror frames or recesses are clean, free of obstructions, and ready for installation of mirrors.

### **3.02 PREPARATION**

- A. Clean contact surfaces with solvent and wipe dry.

### **3.03 INSTALLATION**

- A. Install mirrors in accordance with manufacturer's recommendations.
- B. Set mirrors plumb and level, and free of optical distortion.
- C. Set mirrors with edge clearance free of surrounding construction including countertops or backsplashes.
- D. Install mirror +22" A.F.F.; avoid electrical outlets
- E. Frameless Mirrors: Set mirrors with clips, and anchor rigidly to wall construction.

### **3.04 CLEANING**

- A. Remove wet glazing materials from finish surfaces.
- B. Remove labels after work is complete.
- C. Clean mirrors and adjacent surfaces.

**END OF SECTION**

**SECTION 092116  
GYPSUM BOARD ASSEMBLIES**

**PART 1 GENERAL**

**1.01 SECTION INCLUDES**

- A. Acoustic insulation.
- B. Gypsum sheathing.
- C. Cementitious backing board.
- D. Gypsum wallboard.
- E. Joint treatment and accessories.
- F. Textured finish system.

**1.02 RELATED REQUIREMENTS**

- A. Section 016116 - Volatile Organic Compound (VOC) Content Restrictions.
- B. Section 061000 - Rough Carpentry: Building framing and sheathing.
- C. Section 061000 - Rough Carpentry: Wood blocking product and execution requirements.
- D. Section 079200 - Joint Sealants: Sealing acoustical gaps in construction other than gypsum board or plaster work.
- E. Section 092216 - Non-Structural Metal Framing.

**1.03 REFERENCE STANDARDS**

- A. AISI S100 - North American Specification for the Design of Cold-Formed Steel Structural Members; 2016, with Supplement (2020).
- B. ANSI A108.11 - American National Standard Specifications for Interior Installation of Cementitious Backer Units; 2018.
- C. ANSI A118.9 - American National Standard Specifications for Test Methods and Specifications for Cementitious Backer Units; 2019.
- D. ASTM C475/C475M - Standard Specification for Joint Compound and Joint Tape for Finishing Gypsum Board; 2017 (Reapproved 2022).
- E. ASTM C557 - Standard Specification for Adhesives for Fastening Gypsum Wallboard to Wood Framing; 2003 (Reapproved 2017).
- F. ASTM C645 - Standard Specification for Nonstructural Steel Framing Members; 2018.
- G. ASTM C754 - Standard Specification for Installation of Steel Framing Members to Receive Screw-Attached Gypsum Panel Products; 2020.
- H. ASTM C840 - Standard Specification for Application and Finishing of Gypsum Board; 2023.
- I. ASTM C954 - Standard Specification for Steel Drill Screws for the Application of Gypsum Panel Products or Metal Plaster Bases to Steel Studs from 0.033 in. (0.84 mm) to 0.112 in. (2.84 mm) in Thickness; 2022.
- J. ASTM C1002 - Standard Specification for Steel Self-Piercing Tapping Screws for Application of Gypsum Panel Products or Metal Plaster Bases to Wood Studs or Steel Studs; 2022.
- K. ASTM C1047 - Standard Specification for Accessories for Gypsum Wallboard and Gypsum Veneer Base; 2019.
- L. ASTM C1396/C1396M - Standard Specification for Gypsum Board; 2017.
- M. ASTM E84 - Standard Test Method for Surface Burning Characteristics of Building Materials; 2023c.
- N. ASTM E1414/E1414M - Standard Test Method for Airborne Sound Attenuation Between Rooms Sharing a Common Ceiling Plenum; 2021a.
- O. GA-216 - Application and Finishing of Gypsum Panel Products; 2021.

#### 1.04 SUBMITTALS

- A. See Section 013000 - Administrative Requirements for submittal procedures.
- B. Product Data: Provide data on gypsum board, accessories, and joint finishing system.

#### 1.05 QUALITY ASSURANCE

- A. Installer Qualifications: Company specializing in performing gypsum board installation and finishing, with minimum 5 years of documented experience.

### PART 2 PRODUCTS

#### 2.01 GYPSUM BOARD ASSEMBLIES

- A. Provide completed assemblies complying with ASTM C840 and GA-216.

#### 2.02 METAL FRAMING MATERIALS

- A. Manufacturers - Metal Framing, Connectors, and Accessories:
  - 1. ClarkDietrich: [www.clarkdietrich.com/#sle](http://www.clarkdietrich.com/#sle).
  - 2. Substitutions: See Section 016000 - Product Requirements.
- B. Non-structural Framing System Components: ASTM C645; galvanized sheet steel, of size and properties necessary to comply with ASTM C754 for the spacing indicated, with maximum deflection of wall framing of L/120 at 5 psf (L/120 at 240 Pa).
  - 1. Resilient Furring Channels: Double leg configuration; 7/8 inch (\_\_\_\_ mm) channel depth.
    - a. Products:
      - 1) ClarkDietrich; RC Deluxe Resilient Channel: [www.clarkdietrich.com/#sle](http://www.clarkdietrich.com/#sle).
      - 2) Substitutions: See Section 016000 - Product Requirements.

#### 2.03 BOARD MATERIALS

- A. Manufacturers - Gypsum-Based Board:
  - 1. American Gypsum Company: [www.americangypsum.com/#sle](http://www.americangypsum.com/#sle).
  - 2. CertainTeed Corporation: [www.certainteed.com/#sle](http://www.certainteed.com/#sle).
  - 3. Georgia-Pacific Gypsum: [www.gpgypsum.com/#sle](http://www.gpgypsum.com/#sle).
  - 4. National Gypsum Company: [www.nationalgypsum.com/#sle](http://www.nationalgypsum.com/#sle).
  - 5. USG Corporation: [www.usg.com/#sle](http://www.usg.com/#sle).
  - 6. Substitutions: See Section 016000 - Product Requirements.
- B. Gypsum Wallboard: Paper-faced gypsum panels as defined in ASTM C1396/C1396M; sizes to minimize joints in place; ends square cut.
  - 1. Application: Use for vertical surfaces and ceilings, unless otherwise indicated.
  - 2. Thickness:
    - a. Vertical Surfaces: 5/8 inch (16 mm).
    - b. Ceilings: 1/2 inch (13 mm).
  - 3. Paper-Faced Products:
    - a. Type 'X' and Type 'C' as indicated..

#### 2.04 GYPSUM WALLBOARD ACCESSORIES

- A. Beads, Joint Accessories, and Other Trim: ASTM C1047, rigid plastic, galvanized steel, or rolled zinc, unless noted otherwise.
  - 1. Corner Beads: Low profile, for 90 degree outside corners.
  - 2. Control Joints:
    - a. Depth: 1/2 inch.
    - b. Width: 3/8 inch.
    - c. Shapes: As indicated on Drawings.
    - d. Finish: Buffed Bright Stainless Steel
    - e. Product:
      - 1) Fry Reglet: [www.fryreglet.com](http://www.fryreglet.com) (Basis of Design)
      - 2) Trim-tex, Inc.: [www.trim-tex.com/#sle](http://www.trim-tex.com/#sle)
      - 3) Substitutions: See Section 01 6000 - Product Requirements.



- B. Joint Materials: ASTM C475/C475M and as recommended by gypsum board manufacturer for project conditions.
- C. Screws for Fastening of Gypsum Panel Products to Cold-Formed Steel Studs Less than 0.033 inches (0.84 mm) in Thickness and Wood Members: ASTM C1002; self-piercing tapping screws, corrosion-resistant.
- D. Screws for Fastening of Gypsum Panel Products to Steel Members from 0.033 to 0.112 inch (0.84 to 2.84 mm) in Thickness: ASTM C954; steel drill screws, corrosion-resistant.

### **PART 3 EXECUTION**

#### **3.01 EXAMINATION**

- A. Verify that project conditions are appropriate for work of this section to commence.

#### **3.02 ACOUSTIC ACCESSORIES INSTALLATION**

- A. Acoustic Insulation: Place tightly within spaces, around cut openings, behind and around electrical and mechanical items within partitions, and tight to items passing through partitions.
- B. Acoustic Sealant: Install in accordance with manufacturer's instructions.

#### **3.03 BOARD INSTALLATION**

- A. Comply with ASTM C840, GA-216, and manufacturer's instructions. Install to minimize butt end joints, especially in highly visible locations.
- B. Single-Layer Nonrated: Install gypsum board in most economical direction, with ends and edges occurring over firm bearing.

#### **3.04 INSTALLATION OF TRIM AND ACCESSORIES**

- A. Control Joints: Place control joints consistent with lines of building spaces and as indicated.
- B. Corner Beads: Install at external corners, using longest practical lengths.

#### **3.05 JOINT TREATMENT**

- A. Finish gypsum board in accordance with levels defined in ASTM C840, as follows:
  - 1. Level 4: Walls to receive paint finish, unless otherwise indicated.
  - 2. Level 3: Ceilings to receive textured ceiling finish.
- B. Tape, fill, and sand exposed joints, edges, and corners to produce smooth surface ready to receive finishes.
  - 1. Feather coats of joint compound so that camber is maximum 1/32 inch (0.8 mm).

#### **3.06 TEXTURE FINISH**

- A. Apply finish texture coating by means of spraying apparatus in accordance with manufacturer's instructions and to match approved sample.
- B. Texture Required: Splatter.

#### **3.07 TOLERANCES**

- A. Maximum Variation of Finished Gypsum Board Surface from True Flatness: 1/8 inch in 10 feet (3 mm in 3 m) in any direction.

**END OF SECTION**

**SECTION 096500  
RESILIENT FLOORING**

**PART 1 GENERAL**

**1.01 SECTION INCLUDES**

- A. Resilient tile flooring.
- B. Resilient base.
- C. Resilient stair accessories.
- D. Installation accessories.

**1.02 RELATED REQUIREMENTS**

- A. Section 016116 - Volatile Organic Compound (VOC) Content Restrictions.
- B. Section 033000 - Cast-in-Place Concrete: Restrictions on curing compounds for concrete slabs and floors to receive adhesive-applied resilient flooring.
- C. Section 090561 - Common Work Results for Flooring Preparation: Concrete slab moisture and alkalinity testing and remediation procedures.

**1.03 REFERENCE STANDARDS**

- A. ASTM E648 - Standard Test Method for Critical Radiant Flux of Floor-Covering Systems Using a Radiant Heat Energy Source; 2023.
- B. ASTM F710 - Standard Practice for Preparing Concrete Floors to Receive Resilient Flooring; 2022.
- C. ASTM F1344 - Standard Specification for Rubber Floor Tile; 2021a.
- D. ASTM F1700 - Standard Specification for Solid Vinyl Floor Tile; 2020.
- E. ASTM F1861 - Standard Specification for Resilient Wall Base; 2021.
- F. ASTM F1869 - Standard Test Method for Measuring Moisture Vapor Emission Rate of Concrete Subfloor Using Anhydrous Calcium Chloride; 2023.
- G. ASTM F2169 - Standard Specification for Resilient Stair Treads; 2015 (Reapproved 2020).
- H. ASTM F2170 - Standard Test Method for Determining Relative Humidity in Concrete Floor Slabs Using in situ Probes; 2019a.
- I. NFPA 253 - Standard Method of Test for Critical Radiant Flux of Floor Covering Systems Using a Radiant Heat Energy Source; 2023.

**1.04 SUBMITTALS**

- A. See Section 013000 - Administrative Requirements for submittal procedures.
- B. Product Data: Provide data on specified products, describing physical and performance characteristics; including sizes, patterns and colors available; and installation instructions.
- C. Verification Samples: Submit two samples illustrating color and pattern for each resilient flooring product specified.
- D. Concrete Subfloor Test Report: Submit a copy of the moisture and alkalinity (pH) test reports.
- E. Manufacturer's Qualification Statement.
- F. Installer's Qualification Statement.
- G. Manufacturer's Warranty
- H. Maintenance Data: Include maintenance procedures, recommended maintenance materials, and suggested schedule for cleaning, stripping, and re-waxing.
- I. Maintenance Materials: Furnish the following for Owner's use in maintenance of project.
  - 1. See Section 016000 - Product Requirements, for additional provisions.
  - 2. Extra Flooring Material: Quantity equivalent to 5 percent of each type and color.
  - 3. Extra Wall Base: 2 cartons of each type and color.

4. Extra Stair Materials: Quantity equivalent to 5 percent of each type and color.

### **1.05 QUALITY ASSURANCE**

- A. Manufacturer Qualifications: Company specializing in manufacturing specified flooring with minimum five years documented experience.
- B. Installer Qualifications: Company specializing in installing specified flooring with minimum five years documented experience.

### **1.06 DELIVERY, STORAGE, AND HANDLING**

- A. Upon receipt, immediately remove any shrink-wrap and check materials for damage and the correct style, color, quantity and run numbers.
- B. Store all materials off of the floor in an acclimatized, weather-tight space.
- C. Maintain temperature in storage area between 55 degrees F (13 degrees C) and 90 degrees F (72 degrees C).
- D. Protect roll materials from damage by storing on end.
- E. Do not double stack pallets.

### **1.07 FIELD CONDITIONS**

- A. Store materials for not less than 48 hours prior to installation in area of installation at a temperature of 70 degrees F (21 degrees C) to achieve temperature stability. Thereafter, maintain conditions above 55 degrees F (13 degrees C).

## **PART 2 PRODUCTS**

### **2.01 TILE FLOORING**

- A. Vinyl Tile - Type B, Class III (Glue Down): Solid Vinyl Floor Tile.
  1. Manufacturer:
    - a. EF Contract Flooring: [www.efcontractflooring.com](http://www.efcontractflooring.com)
    - b. Product Rep: Mike Smith (317) 850-5888 (email)  
[Michael.Smith@efcontractflooring.com](mailto:Michael.Smith@efcontractflooring.com)
  2. Style: Woodlands
  3. Wear Layer: 20 mil
  4. Overall Thickness: 2.5mm
  5. Dimensions: 7 inch by 48 inch
  6. Color: As indicated on drawings
  7. Finish/Coating: Enhanced UV Urethane with Ceramic Micro Bead
  8. Pattern Repeat: Random Wood
  9. Gloss Level: Matte Finish
  10. Commercial Traffic: Heavy Commercial
  11. ASTM E648 Critical Radiant Flux: Class 1
  12. ASTM E662 Smoke Density: Passes
  13. Installation Method: Ashlar

### **2.02 STAIR COVERING**

- A. Stair Treads: Rubber; full width and depth of stair tread in one piece; homogeneous composition of 100% synthetic rubber.
  1. Manufacturers:
    - a. Tarkett: [www.tarkett.com/#sle](http://www.tarkett.com/#sle).
    - b. Substitutions: See Section 016000 - Product Requirements.
  2. Product: Angle Fit Rubber Stair Treads; ADA compliant
  3. Type: Raised Round Surface
  4. Nosing: Square.
  5. Smoke Development (ASTM E 662/NFPA 258): less than 450
  6. Color: As indicated on drawings.
- B. Stair Risers: Full height and width of tread in one piece, 2 mm thick vinyl

1. Manufacturers:
    - a. Tarkett: [www.tarkett.com/#sle](http://www.tarkett.com/#sle).
    - b. Color: Same as stair treads
    - c. Substitutions: See Section 016000 - Product Requirements.
  2. Thickness: 0.080 inch (2.0 mm).
- C. Stair Nosing- Resilient vinyl stair nosing; homogeneous composition of PVC
1. Manufacturers:
    - a. Johnsonite, a Tarkett Company: [www.johnsonite.com/#sle](http://www.johnsonite.com/#sle).
  2. Material: Vinyl.
  3. Profile: Square vinyl stair nosing
  4. Color: To match stair treads.

### **2.03 RESILIENT BASE**

- A. Resilient Base - Type TP: ASTM F1861, Type TP, rubber, thermoplastic; style as scheduled.
1. Manufacturers:
    - a. Johnsonite, a Tarkett Company: [www.johnsonite.com/#sle](http://www.johnsonite.com/#sle).
    - b. Substitutions: See Section 016000 - Product Requirements.
  2. Height: 4 inches (100 mm), coved
  3. Thickness: 0.125 inch (3.2 mm).
  4. Finish: Matte.
  5. Length: Roll.
  6. Flammability (ASTM E648): Class 1
  7. Color: As indicated on drawings.

### **2.04 ACCESSORIES**

- A. Primers and Seam Sealer: Waterproof; types recommended by flooring manufacturer.
1. VOC Content Limits: As specified in Section 016116.
- B. Required adhesive for Vinyl Tile Flooring:
1. Commercialon Premium Modular and LVT adhesive.
  2. Installation Method: Full Spread
- C. Adhesive for Tarkett Base and Stair Treads/Risers
1. Recommended by Tarkett.
- D. Reducer Strips: Vinyl
1. Manufacturers:
    - a. Tarkett: [www.tarkett.com/#sle](http://www.tarkett.com/#sle).
- E. Filler for Coved Base: Plastic.

## **PART 3 EXECUTION**

### **3.01 EXAMINATION**

- A. Verify that surfaces are flat to tolerances acceptable to flooring manufacturer, free of cracks that might telegraph through flooring, clean, dry, and free of curing compounds, surface hardeners, and other chemicals that might interfere with bonding of flooring to substrate.
- B. Cementitious Subfloor Surfaces: Verify that substrates are ready for resilient flooring installation by testing for moisture and alkalinity (pH).
1. Test as Follows:
    - a. Alkalinity (pH): ASTM F710.
    - b. Internal Relative Humidity: ASTM F2170.
    - c. Moisture Vapor Emission: ASTM F1869.
  2. Obtain instructions if test results are not within limits recommended by resilient flooring manufacturer and adhesive materials manufacturer.

### **3.02 PREPARATION**

- A. Prepare floor substrates as recommended by flooring and adhesive manufacturers.

- B. Clean substrate.

### **3.03 INSTALLATION - GENERAL**

- A. Starting installation constitutes acceptance of subfloor conditions.
- B. Install in accordance with manufacturer's written instructions.

### **3.04 INSTALLATION - TILE FLOORING**

- A. Mix tile from container to ensure shade variations are consistent when tile is placed, unless otherwise indicated in manufacturer's installation instructions.
- B. Install square tile to ashlar pattern. Allow minimum 1/2 full size tile width at room or area perimeter.

### **3.05 INSTALLATION - RESILIENT BASE**

- A. Fit joints tightly and make vertical. Maintain minimum dimension of 18 inches (45 mm) between joints.
- B. Install base on solid backing. Bond tightly to wall and floor surfaces.
- C. Scribe and fit to door frames and other interruptions.

### **3.06 INSTALLATION - STAIR COVERINGS**

- A. Install stair coverings in one piece for full width and depth of tread.
- B. Adhere over entire surface. Fit accurately and securely.

### **3.07 CLEANING**

- A. Remove excess adhesive from floor, base, and wall surfaces without damage.
- B. Clean in accordance with manufacturer's written instructions.

### **3.08 PROTECTION**

- A. Prohibit traffic on resilient flooring for 48 hours after installation.

**END OF SECTION**

**SECTION 096813  
TILE CARPETING**

**PART 1 GENERAL**

**1.01 SECTION INCLUDES**

- A. Carpet tile, fully adhered.

**1.02 RELATED REQUIREMENTS**

- A. Section 016116 - Volatile Organic Compound (VOC) Content Restrictions.
- B. Section 033000 - Cast-in-Place Concrete: Restrictions on curing compounds for concrete slabs and floors to receive adhesive-applied flooring.
- C. Section 090561 - Common Work Results for Flooring Preparation: Removal of existing floor coverings, cleaning, and preparation.

**1.03 REFERENCE STANDARDS**

- A. ASTM F710 - Standard Practice for Preparing Concrete Floors to Receive Resilient Flooring; 2022.
- B. ASTM F1869 - Standard Test Method for Measuring Moisture Vapor Emission Rate of Concrete Subfloor Using Anhydrous Calcium Chloride; 2023.
- C. ASTM F2170 - Standard Test Method for Determining Relative Humidity in Concrete Floor Slabs Using in situ Probes; 2019a.
- D. CRI 104 - Standard for Installation of Commercial Carpet; 2015.

**1.04 SUBMITTALS**

- A. See Section 013000 - Administrative Requirements, for submittal procedures.
- B. Product Data: Provide data on specified products, describing physical and performance characteristics; sizes, patterns, colors available, and method of installation.
- C. Samples: Submit two carpet tiles illustrating color and pattern design for each carpet color selected.
- D. Concrete Subfloor Test Report: Submit a copy of the moisture and alkalinity (pH) test reports.
- E. Manufacturer's Qualification Statement.
- F. Installer's Qualification Statement.
- G. Operation and Maintenance Data: Include maintenance procedures, recommended maintenance materials, and suggested schedule for cleaning.
- H. Maintenance Materials: Furnish the following for Owner's use in maintenance of project.
  - 1. See Section 016000 - Product Requirements, for additional provisions.
  - 2. Extra Carpet Tiles: Quantity equal to 5 percent of total installed of each color and pattern installed.

**1.05 QUALITY ASSURANCE**

- A. Manufacturer Qualifications: Company specializing in manufacturing specified carpet tile with minimum five years documented experience.
- B. Installer Qualifications: Company specializing in installing carpet tile with minimum five years documented experience and approved by carpet tile manufacturer.

**1.06 FIELD CONDITIONS**

- A. Store materials in area of installation for minimum period of 24 hours prior to installation.

**PART 2 PRODUCTS**

**2.01 MANUFACTURERS**

- A. Tile Carpeting:
  - 1. EF Contract: [www.efcontractflooring.com/#sle](http://www.efcontractflooring.com/#sle).

- a. Product Rep: Mike Smith (317) 850-5888 (email)  
michael.smith@efcontractflooring.com

## **2.02 MATERIALS**

- A. Tile Carpeting (CPT-1): Textured loop walk-off tile, manufactured in one color dye lot.
  - 1. Pattern: Access / AX
  - 2. Dimensions: 24" by 24"
  - 3. Face Weight: 30 oz.
  - 4. Gauge: 1/10
  - 5. Color: As indicated on drawings
  - 6. Dye Method: Solution Dyed
  - 7. Primary Backing: Nexus Modular
  - 8. Flooring Radiant Panel:
  - 9. Smoke Density: Less than 450 flaming (ASTM E 662)
  - 10. Pill Test: Yes
  - 11. Installation Method: Quarter Turn

## **2.03 ACCESSORIES**

- A. Subfloor Filler: White premix latex; type recommended by flooring material manufacturer.
- B. Reducer Strips: Johnsonite vinyl reducer strip.
- C. Stair Nosing: As specified in Section 096500.
- D. Carpet Tile Adhesive: Recommended by carpet tile manufacturer.

## **PART 3 EXECUTION**

### **3.01 EXAMINATION**

- A. Verify that wall surfaces are smooth and flat within the tolerances specified for that type of work, are dust-free, and are ready to receive carpet tile.
- B. Cementitious Subfloor Surfaces: Verify that substrates are ready for flooring installation by testing for moisture and alkalinity (pH).
  - 1. Test in accordance with Section 090561.
  - 2. Test as Follows:
    - a. Alkalinity (pH): ASTM F710.
    - b. Internal Relative Humidity: ASTM F2170.
    - c. Moisture Vapor Emission: ASTM F1869.
  - 3. Obtain instructions if test results are not within limits recommended by flooring material manufacturer and adhesive materials manufacturer.

### **3.02 PREPARATION**

- A. Prepare floor substrates as recommended by flooring and adhesive manufacturers.
- B. Remove subfloor ridges and bumps. Fill minor or local low spots, cracks, joints, holes, and other defects with subfloor filler.
- C. Vacuum clean substrate.

### **3.03 INSTALLATION**

- A. Starting installation constitutes acceptance of subfloor conditions.
- B. Install carpet tile in accordance with manufacturer's instructions.
- C. Blend carpet from different cartons to ensure minimal variation in color match.
- D. Cut carpet tile clean. Fit carpet tight to intersection with vertical surfaces without gaps.
- E. Lay carpet tile in square pattern, with pile direction parallel to next unit, set parallel to building lines.
- F. Trim carpet tile neatly at walls and around interruptions.
- G. Complete installation of edge strips, concealing exposed edges.

### **3.04 INSTALLATION ON STAIRS**

- A. Use one piece of carpet for each tread and the riser below. Apply seam adhesive to all cut edges.
- B. Lay carpet with pile direction in the length of the stair.
- C. Adhere carpet tight to stair treads and risers.

### **3.05 CLEANING**

- A. Remove excess adhesive without damage, from floor, base, and wall surfaces.
- B. Clean and vacuum carpet surfaces.

**END OF SECTION**



**SECTION 099113  
EXTERIOR PAINTING**

**PART 1 GENERAL**

**1.01 SECTION INCLUDES**

- A. Surface preparation.
- B. Field application of paints.
- C. Materials for backpriming woodwork.
- D. Scope: Finish exterior surfaces exposed to view, unless fully factory-finished and unless otherwise indicated, including the following:
  - 1. Exposed surfaces of steel lintels and ledge angles.
  - 2. Hollow metal doors and frames.
  - 3. Wood frames and trim.
  - 4. Other exposed wood surfaces.
- E. Do Not Paint or Finish the Following Items:
  - 1. Items factory-finished unless otherwise indicated; materials and products having factory-applied primers are not considered factory finished.
  - 2. Items indicated to receive other finishes.
  - 3. Items indicated to remain unfinished.
  - 4. Fire rating labels, equipment serial number and capacity labels, and operating parts of equipment.
  - 5. Floors, unless specifically indicated.
  - 6. Glass.
  - 7. Concealed pipes, ducts, and conduits.

**1.02 RELATED REQUIREMENTS**

**1.03 REFERENCE STANDARDS**

- A. 40 CFR 59, Subpart D - National Volatile Organic Compound Emission Standards for Architectural Coatings; U.S. Environmental Protection Agency; current edition.
- B. ASTM D16 - Standard Terminology for Paint, Related Coatings, Materials, and Applications; 2023.
- C. ASTM D4258 - Standard Practice for Surface Cleaning Concrete for Coating; 2023.
- D. ASTM D4259 - Standard Practice for Preparation of Concrete by Abrasion Prior to Coating Application; 2018.
- E. ASTM D4442 - Standard Test Methods for Direct Moisture Content Measurement of Wood and Wood-Based Materials; 2020.
- F. MPI (APL) - Master Painters Institute Approved Products List; Master Painters and Decorators Association; Current Edition.
- G. MPI (APSM) - Master Painters Institute Architectural Painting Specification Manual; Current Edition.
- H. SCAQMD 1113 - Architectural Coatings; 1977, with Amendment (2016).
- I. SSPC V1 (PM1) - Good Painting Practice: Painting Manual Volume 1; 2016.
- J. SSPC-SP 1 - Solvent Cleaning; 2015, with Editorial Revision (2016).
- K. SSPC-SP 6 - Commercial Blast Cleaning; 2007.
- L. SSPC-SP 13 - Surface Preparation of Concrete; 2018.

**1.04 SUBMITTALS**

- A. See Section 013000 - Administrative Requirements, for submittal procedures.
- B. Product Data: Provide complete list of products to be used, with the following information for each:

1. Manufacturer's name, product name and/or catalog number, and general product category (e.g. "alkyd enamel").
  2. MPI product number (e.g. MPI #47).
  3. Cross-reference to specified paint system(s) product is to be used in; include description of each system.
- C. Samples: Submit three paper "draw down" samples, 8-1/2 by 11 inches (216 by 279 mm) in size, illustrating range of colors available for each finishing product specified.
1. Where sheen is specified, submit samples in only that sheen.
  2. Where sheen is not specified, submit each color in each sheen available.
    - a. Where sheen is not specified, discuss sheen options with Architect before preparing samples, to eliminate sheens not required.
- D. Certification: By manufacturer that paints and finishes comply with VOC limits specified.
- E. Manufacturer's Instructions: Indicate special surface preparation procedures.

### **1.05 QUALITY ASSURANCE**

- A. Manufacturer Qualifications: Company specializing in manufacturing the products specified, with minimum five years documented experience.
- B. Applicator Qualifications: Company specializing in performing the type of work specified with minimum 5 years experience and approved by manufacturer.

### **1.06 DELIVERY, STORAGE, AND HANDLING**

- A. Deliver products to site in sealed and labeled containers; inspect to verify acceptability.
- B. Container Label: Include manufacturer's name, type of paint, brand name, lot number, brand code, coverage, surface preparation, drying time, cleanup requirements, color designation, and instructions for mixing and reducing.
- C. Paint Materials: Store at minimum ambient temperature of 45 degrees F (7 degrees C) and a maximum of 90 degrees F (32 degrees C), in ventilated area, and as required by manufacturer's instructions.

### **1.07 FIELD CONDITIONS**

- A. Do not apply materials when surface and ambient temperatures are outside the paint product manufacturer's temperature ranges.
- B. Follow manufacturer's recommended procedures for producing best results, including testing of substrates, moisture in substrates, and humidity and temperature limitations.
- C. Provide lighting level of 80 ft candles (860 lx) measured mid-height at substrate surface.

## **PART 2 PRODUCTS**

### **2.01 MANUFACTURERS**

- A. Paints:
1. PPG Paints: [www.ppgpaints.com/#sle](http://www.ppgpaints.com/#sle).
  2. Sherwin-Williams Company: [www.sherwin-williams.com/#sle](http://www.sherwin-williams.com/#sle).
  3. Substitutions: See Section 01 600 - Product Requirements.
- B. Primer Sealers: Same manufacturer as top coats.
- C. Substitutions: See Section 016000 - Product Requirements.

### **2.02 PAINTS AND FINISHES - GENERAL**

- A. Paints and Finishes: Ready-mixed, unless required to be a field-catalyzed paint.
1. Provide paints and finishes of a soft paste consistency, capable of being readily and uniformly dispersed to a homogeneous coating, with good flow and brushing properties, and capable of drying or curing free of streaks or sags.
  2. Supply each paint material in quantity required to complete entire project's work from a single production run.
  3. Do not reduce, thin, or dilute paint or finishes or add materials unless such procedure is described explicitly in manufacturer's product instructions.

B. Volatile Organic Compound (VOC) Content: Comply with Section 016116.

### **2.03 PAINT SYSTEMS - EXTERIOR**

- A. Paint E-OP - Exterior Surfaces to be Painted, Unless Otherwise Indicated: Including primed wood and primed metal.
1. Two top coats and one coat primer.
  2. Top Coat(s): Exterior Light Industrial Coating, Water Based; MPI #161, 163, or 164.
    - a. Locations: Exposed steel and hollow metal
    - b. Products:
      - 1) PPG Paints Pitt-Tech Plus DTM Industrial Enamel, 90-1110 Series, Satin. (MPI #161)
      - 2) Sherwin-Williams; Pro Industrial DTM Acrylic.
      - 3) Substitutions: Section 016000 - Product Requirements.
  3. Top Coat(s): Exterior Alkyd Enamel; MPI #94 or 96.
    - a. Locations: Wood door/window frames and other exposed wood sur
    - b. Products:
      - 1) Behr Alkyd Interior/Exterior Semi-Gloss Enamel [No. 3900].
      - 2) Sherwin Williams; Pro Industrial Urethane Alkyd Enamel.

## **PART 3 EXECUTION**

### **3.01 EXAMINATION**

- A. Do not begin application of paints and finishes until substrates have been properly prepared.
- B. Verify that surfaces are ready to receive work as instructed by the product manufacturer.
- C. Examine surfaces scheduled to be finished prior to commencement of work. Report any condition that may potentially effect proper application.
- D. Test shop-applied primer for compatibility with subsequent cover materials.
- E. Measure moisture content of surfaces using an electronic moisture meter. Do not apply finishes unless moisture content of surfaces are below the following maximums:
  1. Exterior Wood: 15 percent, measured in accordance with ASTM D4442.

### **3.02 PREPARATION**

- A. Clean surfaces thoroughly and correct defects prior to application.
- B. Prepare surfaces using the methods recommended by the manufacturer for achieving the best result for the substrate under the project conditions.
- C. Remove or repair existing paints or finishes that exhibit surface defects.
- D. Remove or mask surface appurtenances, including electrical plates, hardware, light fixture trim, escutcheons, and fittings, prior to preparing surfaces for finishing.
- E. Seal surfaces that might cause bleed through or staining of topcoat.
- F. Remove mildew from impervious surfaces by scrubbing with solution of tetra-sodium phosphate and bleach. Rinse with clean water and allow surface to dry.
- G. Masonry:
  1. Remove efflorescence and chalk. Do not coat surfaces if moisture content or alkalinity of surfaces or if alkalinity of mortar joints exceed that permitted in manufacturer's written instructions. Allow to dry.
  2. Prepare surface as recommended by top coat manufacturer.
  3. Clean surfaces with pressurized water. Use pressure range of 600 to 1,500 psi (4,140 to 10,350 kPa) at 6 to 12 inches (150 to 300 mm). Allow to dry.
- H. Aluminum: Remove surface contamination and oils and wash with solvent according to SSPC-SP 1.
- I. Ferrous Metal:
  1. Solvent clean according to SSPC-SP 1.

2. Remove rust, loose mill scale, and other foreign substances using methods recommended in writing by paint manufacturer and blast cleaning according to SSPC-SP 6 "Commercial Blast Cleaning". Protect from corrosion until coated.
- J. Exterior Wood Surfaces to Receive Opaque Finish: Remove dust, grit, and foreign matter. Seal knots, pitch streaks, and sappy sections. Fill nail holes with tinted exterior calking compound after prime coat has been applied. Back prime concealed surfaces before installation.

### **3.03 APPLICATION**

- A. Exterior Wood to Receive Opaque Finish: If final painting must be delayed more than 2 weeks after installation of woodwork, apply primer within 2 weeks and final coating within 4 weeks.
- B. Apply products in accordance with manufacturer's written instructions and recommendations in "MPI Architectural Painting Specification Manual".
- C. Do not apply finishes to surfaces that are not dry. Allow applied coats to dry before next coat is applied.
- D. Apply each coat to uniform appearance.
- E. Vacuum clean surfaces of loose particles. Use tack cloth to remove dust and particles just prior to applying next coat.
- F. Reinstall electrical cover plates, hardware, light fixture trim, escutcheons, and fittings removed prior to finishing.

### **3.04 CLEANING**

- A. Collect waste material that could constitute a fire hazard, place in closed metal containers, and remove daily from site.

### **3.05 PROTECTION**

- A. Protect finishes until completion of project.
- B. Touch-up damaged finishes after Substantial Completion.

**END OF SECTION**

**SECTION 099123  
INTERIOR PAINTING**

**PART 1 GENERAL**

**1.01 SECTION INCLUDES**

- A. Surface preparation.
- B. Field application of paints.
- C. Scope: Finish interior surfaces exposed to view, unless fully factory-finished and unless otherwise indicated.
- D. Do Not Paint or Finish the Following Items:
  - 1. Items factory-finished unless otherwise indicated; materials and products having factory-applied primers are not considered factory finished.
  - 2. Items indicated to receive other finishes.
  - 3. Items indicated to remain unfinished.
  - 4. Fire rating labels, equipment serial number and capacity labels, bar code labels, and operating parts of equipment.
  - 5. Floors, unless specifically indicated.
  - 6. Glass.
  - 7. Concealed pipes, ducts, and conduits.

**1.02 RELATED REQUIREMENTS**

- A. Section 099113 - Exterior Painting.

**1.03 REFERENCE STANDARDS**

- A. ASTM D4442 - Standard Test Methods for Direct Moisture Content Measurement of Wood and Wood-Based Materials; 2020.
- B. MPI (APSM) - Master Painters Institute Architectural Painting Specification Manual; Current Edition.
- C. SSPC-SP 1 - Solvent Cleaning; 2015, with Editorial Revision (2016).
- D. SSPC-SP 6 - Commercial Blast Cleaning; 2007.

**1.04 SUBMITTALS**

- A. See Section 013000 - Administrative Requirements, for submittal procedures.
- B. Product Data: Provide complete list of products to be used, with the following information for each:
  - 1. Manufacturer's name, product name and/or catalog number, and general product category (e.g., "alkyd enamel").
  - 2. MPI product number (e.g., MPI #47).
  - 3. Cross-reference to specified paint system products to be used in project; include description of each system.
- C. Samples: Submit two paper "draw down" samples, 8-1/2 by 11 inches (216 by 279 mm) in size, illustrating range of colors available for each finishing product specified.
  - 1. Where sheen is specified, submit samples in only that sheen.
- D. Certification: By manufacturer that paints and finishes comply with VOC limits specified.
- E. Maintenance Data: Submit data including finish schedule showing where each product/color/finish was used, product technical data sheets, material safety data sheets (MSDS), care and cleaning instructions, touch-up procedures, repair of painted and finished surfaces, and color samples of each color and finish used.
- F. Maintenance Materials: Furnish the following for Owner's use in maintenance of project.
  - 1. See Section 016000 - Product Requirements, for additional provisions.
  - 2. Extra Paint and Finish Materials: 1 gal (4 L) of each color; from the same product run, store where directed.

3. Label each container with color in addition to the manufacturer's label.

### **1.05 QUALITY ASSURANCE**

- A. Manufacturer Qualifications: Company specializing in manufacturing the products specified, with minimum five years documented experience.
- B. Applicator Qualifications: Company specializing in performing the type of work specified with minimum five years experience and approved by manufacturer.

### **1.06 DELIVERY, STORAGE, AND HANDLING**

- A. Deliver products to site in sealed and labeled containers; inspect to verify acceptability.
- B. Container Label: Include manufacturer's name, type of paint, brand name, lot number, brand code, coverage, surface preparation, drying time, cleanup requirements, color designation, and instructions for mixing and reducing.
- C. Paint Materials: Store at minimum ambient temperature of 45 degrees F (7 degrees C) and a maximum of 90 degrees F (32 degrees C), in ventilated area, and as required by manufacturer's instructions.

### **1.07 FIELD CONDITIONS**

- A. Do not apply materials when surface and ambient temperatures are outside the temperature ranges required by the paint product manufacturer.
- B. Follow manufacturer's recommended procedures for producing best results, including testing of substrates, moisture in substrates, and humidity and temperature limitations.
- C. Provide lighting level of 80 fc (860 lux) measured mid-height at substrate surface.

## **PART 2 PRODUCTS**

### **2.01 MANUFACTURERS**

- A. Provide paints and finishes used in any individual system from the same manufacturer; no exceptions.
- B. Paints:
  1. Base Manufacturer: Sherwin Williams.
  2. PPG Paints: [www.ppgpaints.com/#sle](http://www.ppgpaints.com/#sle).
  3. Sherwin-Williams Company: [www.sherwin-williams.com/#sle](http://www.sherwin-williams.com/#sle).
- C. Primer Sealers: Same manufacturer as top coats.
- D. Substitutions: See Section 016000 - Product Requirements.

### **2.02 PAINTS AND FINISHES - GENERAL**

- A. Paints and Finishes: Ready-mixed, unless intended to be a field-catalyzed paint.
  1. Provide paints and finishes of a soft paste consistency, capable of being readily and uniformly dispersed to a homogeneous coating, with good flow and brushing properties, and capable of drying or curing free of streaks or sags.
  2. Supply each paint material in quantity required to complete entire project's work from a single production run.
  3. Do not reduce, thin, or dilute paint or finishes or add materials unless such procedure is specifically described in manufacturer's product instructions.
- B. Sheens: Provide the sheens specified; where sheen is not specified, sheen will be selected later by Architect from the manufacturer's full line.
- C. Colors: As indicated on drawings.

### **2.03 PAINT SYSTEMS - INTERIOR**

- A. Paint I-OP - Interior Surfaces to be Painted, Unless Otherwise Indicated: Including gypsum board, concrete, wood, uncoated steel, shop primed steel, galvanized steel, and aluminum.
  1. Two top coats and one coat primer.
  2. Top Coat(s): High Performance Architectural Interior Latex; MPI #138, 139, 140, 141, or 142.

- a. Products:
  - 1) Sherwin-Williams Pre-Catalyzed Waterbased Epoxy, Eg-Shel. (MPI #139)
  - 2) Sherwin-Williams Pre-Catalyzed Waterbased Epoxy, Semi-Gloss. (MPI #141)
- 3. Top Coat(s): Institutional Low Odor/VOC Interior Latex; MPI #143, 144, 145, 146, 147, or 148.
  - a. Products:
    - 1) Sherwin-Williams ProMar 200 Zero VOC Interior Latex, Flat.
    - 2) Sherwin-Williams ProMar 200 Zero VOC Interior Latex, Low Sheen. (MPI #144)

## 2.04 PRIMERS

- A. Primers: Provide the following unless other primer is required or recommended by manufacturer of top coats.
  - 1. Interior Latex Primer Sealer; MPI #50.
    - a. Products:
      - 1) Sherwin Williams Promar 200 Zero VOC Latex Primer/Sealer.
      - 2) Substitutions: See Section 016000 - Product Requirements
  - 2. Interior Water Based Primer for Galvanized Metal; MPI #134 or #134 X-Green.
    - a. Products:
      - 1) Sherwin-Williams Pro-Cryl Universal Primer. (MPI #134)
      - 2) Substitutions: See Section 016000 - Product Requirements

## PART 3 EXECUTION

### 3.01 EXAMINATION

- A. Verify that surfaces are ready to receive work as instructed by the product manufacturer.
- B. Examine surfaces scheduled to be finished prior to commencement of work. Report any condition that may potentially affect proper application.
- C. Test shop-applied primer for compatibility with subsequent cover materials.
- D. Measure moisture content of surfaces using an electronic moisture meter. Do not apply finishes unless moisture content of surfaces is below the following maximums:
  - 1. Gypsum Wallboard: 12 percent.
  - 2. Masonry, Concrete, and Concrete Masonry Units: 12 percent.
  - 3. Interior Wood: 15 percent, measured in accordance with ASTM D4442.

### 3.02 PREPARATION

- A. Clean surfaces thoroughly and correct defects prior to application.
- B. Prepare surfaces using the methods recommended by the manufacturer for achieving the best result for the substrate under the project conditions.
- C. Remove or mask surface appurtenances, including electrical plates, hardware, light fixture trim, escutcheons, and fittings, prior to preparing surfaces or finishing.
- D. Seal surfaces that might cause bleed through or staining of topcoat.
- E. Concrete:
- F. Gypsum Board: Fill minor defects with filler compound. Spot prime defects after repair.
- G. Aluminum: Remove surface contamination and oils and wash with solvent according to SSPC-SP 1.
- H. Galvanized Surfaces:
- I. Ferrous Metal:
  - 1. Solvent clean according to SSPC-SP 1.
  - 2. Shop-Primed Surfaces: Sand and scrape to remove loose primer and rust. Feather edges to make touch-up patches inconspicuous. Clean surfaces with solvent. Prime bare steel surfaces. Re-prime entire shop-primed item.
  - 3. Remove rust, loose mill scale, and other foreign substances using methods recommended in writing by paint manufacturer and blast cleaning according to SSPC-SP 6 Commercial

Blast Cleaning. Protect from corrosion until coated.

- J. Wood Surfaces to Receive Opaque Finish: Wipe off dust and grit prior to priming. Seal knots, pitch streaks, and sappy sections with sealer. Fill nail holes and cracks after primer has dried; sand between coats. Back prime concealed surfaces before installation.

### **3.03 APPLICATION**

- A. Apply products in accordance with manufacturer's written instructions and recommendations in "MPI Architectural Painting Specification Manual".
- B. Do not apply finishes to surfaces that are not dry. Allow applied coats to dry before next coat is applied.
- C. Apply each coat to uniform appearance in thicknesses specified by manufacturer.
- D. Sand wood and metal surfaces lightly between coats to achieve required finish.
- E. Vacuum clean surfaces of loose particles. Use tack cloth to remove dust and particles just prior to applying next coat.
- F. Reinstall electrical cover plates, hardware, light fixture trim, escutcheons, and fittings removed prior to finishing.

### **3.04 CLEANING**

- A. Collect waste material that could constitute a fire hazard, place in closed metal containers, and remove daily from site.

### **3.05 PROTECTION**

- A. Protect finishes until completion of project.
- B. Touch-up damaged finishes after Substantial Completion.

**END OF SECTION**



## **SECTION 101400 SIGNAGE**

### **PART 1 GENERAL**

#### **1.01 SECTION INCLUDES**

- A. ADA Room Identification Signs

#### **1.02 REFERENCE STANDARDS**

- A. 36 CFR 1191 - Americans with Disabilities Act (ADA) Accessibility Guidelines for Buildings and Facilities; Architectural Barriers Act (ABA) Accessibility Guidelines; current edition.
- B. ADA Standards - 2010 ADA Standards for Accessible Design; 2010.
- C. ICC A117.1 - Accessible and Usable Buildings and Facilities; 2017.

#### **1.03 SUBMITTALS**

- A. Product Data: Manufacturer's printed product literature for each type of sign, indicating sign styles, font, foreground and background colors, locations, overall dimensions of each sign.
- B. Signage Schedule: Provide information sufficient to completely define each sign for fabrication, including room number, room name, other text to be applied, sign and letter sizes, fonts, and colors.
  - 1. When room numbers to appear on signs differ from those on drawings, include the drawing room number on schedule.
  - 2. Submit for approval by Owner through Architect prior to fabrication.
- C. Selection Samples: Where colors are not specified, submit two sets of color selection charts or chips.
- D. Manufacturer's Installation Instructions: Include installation templates and attachment devices.
- E. Manufacturer's Qualification Statement.

#### **1.04 QUALITY ASSURANCE**

- A. Manufacturer Qualifications: Company specializing in manufacturing the products specified in this section with minimum FIVE years of documented experience.

#### **1.05 DELIVERY, STORAGE, AND HANDLING**

- A. Package signs as required to prevent damage before installation.
- B. Store tape adhesive at normal room temperature.

#### **1.06 WARRANTY**

- A. Manufacturer's standard warranty against material and manufacturing defects.
  - 1. FIELD CONDITIONS
    - a. Do not install tape adhesive when ambient temperature is lower than recommended by manufacturer.
    - b. Maintain this minimum temperature during and after installation of signs.

### **PART 2 PRODUCTS**

#### **2.01 MANUFACTURERS**

- A. Tactile-Raised Letters and Picto Signage:
  - 1. Diskey Signage: [www.diskeysign.com](http://www.diskeysign.com).
  - 2. Indiana Signworks: [www.indianasignworks.com](http://www.indianasignworks.com)
  - 3. FASTSIGNS: [www.fastsigns.com/#sle](http://www.fastsigns.com/#sle).
  - 4. Inpro Co: [www.inprocorp.com/#sle](http://www.inprocorp.com/#sle).
  - 5. Substitutions: See Section 016000 - Product Requirements.

#### **2.02 SIGNAGE APPLICATIONS**

- A. Room Identification Signs: Provide a sign for every doorway, whether it has a door or not, not including corridors, lobbies, and similar open areas.
  - 1. Sign Type: ADA compliant signs

2. Wording: Scheduled on drawings on Sheet G102.
3. Provide "tactile" signage, with letters raised minimum 1/32 inch (0.8 mm) and Grade II braille.
4. Text Height: 5/8 inch min.
5. Pictogram Height: 3 1/2" min.
6. Apartment Door Units: Identify with the room numbers indicated on drawings on sheet G102.
7. Service Rooms: Identify with room names.
8. Rest Rooms: Identify with pictograms of a unisex restroom with the name "Restroom" and braille.

## **2.03 SIGN DESIGN & SERIES**

- A. InPro Corp "Aspen Collection": ADA Room Identification Signage (Basis of Design)
  1. Edges: Square.
  2. Corners: Radiused.
  3. Frame Finish: Applied Acrylic (no backplate or border)
  4. Room Identification Signage Size(s): See signage details on drawings on Sheet G102.
  5. Signage Color: To be selected from manufacturer standard colors
  6. Font Style/Color: Bebas font; Color: To be selected from manufacturer standard colors
  7. Wall Mounting of One-Sided Signs: Provide double-sided 3M VHB adhesive with conformable foam core to adhere unframed signage to clean, dry, well-sealed surfaces..

## **2.04 ACCESSORIES**

- A. Tape Adhesive: Double sided tape, permanent adhesive.

## **PART 3 EXECUTION**

### **3.01 EXAMINATION**

- A. Verify that substrate surfaces are ready to receive work.

### **3.02 INSTALLATION**

- A. Install in accordance with manufacturer's instructions.
- B. Locate signs and mount at heights indicated on drawings and in accordance with ADA Standards and ICC A117.1.
  1. If no location is indicated obtain Owner's instructions.
- C. Protect from damage until Date of Substantial Completion; repair or replace damaged items.

**SECTION 102600  
WALL AND DOOR PROTECTION**

**PART 1 GENERAL**

**1.01 SECTION INCLUDES**

- A. Corner guards.

**1.02 RELATED REQUIREMENTS**

- A. Section 061000 - Rough Carpentry: Blocking for wall and corner guard anchors.
- B. Section 092116 - Gypsum Board Assemblies: Placement of supports in stud wall construction.

**1.03 SUBMITTALS**

- A. See Section 013000 - Administrative Requirements for submittal procedures.
- B. Product Data: Indicate physical dimensions, features, wall mounting brackets with mounted measurements, anchorage details, and rough-in measurements.
- C. Samples: Submit samples illustrating component color and finish.
  - 1. Submit two samples of protective wall covering and corner guard color, 6 by 6 inches (152 by 152 mm) square.
- D. Warranty Documentation: Submit manufacturer warranty and ensure that forms have been completed in Owner's name and registered with manufacturer.
- E. Maintenance Data: Manufacturer's instructions for care and cleaning of each type of product. Include information about both recommended and potentially detrimental cleaning materials and methods.

**1.04 DELIVERY, STORAGE, AND HANDLING**

- A. Deliver wall protection items in original, undamaged protective packaging. Label items to designate installation locations.
- B. Do not deliver products to project site until areas for storage and installation are fully enclosed, and interior temperature and humidity are in compliance with manufacturer's recommendations for each type of item.
- C. Store products in either horizontal or vertical position, in compliance with manufacturer's instructions.

**1.05 WARRANTY**

- A. See Section 017800 - Closeout Submittals for additional warranty requirements.

**PART 2 PRODUCTS**

**2.01 MANUFACTURERS**

- A. Bumper Rails and Corner Guards:
  - 1. Construction Specialties, Inc, Wall Protection Corner Guards: [www.c-sgroup.com/#sle](http://www.c-sgroup.com/#sle).
    - a. Model: Acrovyn SM-20AN Corner Guard
      - 1) Substitutions: See Section 016000 - Product Requirements.

**2.02 PRODUCT TYPES**

- A. Corner Guards - Surface Mounted:
  - 1. Material: High impact vinyl with full height extruded aluminum retainer.
  - 2. Width of Wings: 3 inches (76 mm).
  - 3. Corner: Radiused.
  - 4. Color: As indicated on drawings.
  - 5. Angle: 90 degrees
  - 6. Length: 5'-0"
  - 7. Preformed end caps.

**2.03 FABRICATION**

- A. Fabricate components with tight joints, corners and seams.

## **PART 3 EXECUTION**

### **3.01 EXAMINATION**

- A. Verify that rough openings, concealed blocking, and anchors are correctly sized and located.
- B. Verify that substrate surfaces for adhered items are clean and smooth.
- C. Start of installation constitutes acceptance of project conditions.

### **3.02 INSTALLATION**

- A. Install components in accordance with manufacturer's instructions, level and plumb, secured rigidly in position to supporting construction.
- B. Position corner guard 4 inches (102 mm) above finished floor. Abut next to wall base.

### **3.03 CLEANING**

- A. Clean wall and door protection items of excess adhesive, dust, dirt, and other contaminants.

**END OF SECTION**

**SECTION 105500  
POSTAL SPECIALTIES**

**PART 1 GENERAL**

**1.01 SECTION INCLUDES**

- A. Central mail delivery boxes.

**1.02 RELATED REQUIREMENTS**

- A. Section 033000 - Cast-in-Place Concrete: Concrete pedestal and anchor bolts for mail box.
- B. Section 055000 - Metal Fabrications: Fabricated metal pedestal and anchor bolts for mail box.

**1.03 REFERENCE STANDARDS**

- A. 36 CFR 1191 - Americans with Disabilities Act (ADA) Accessibility Guidelines for Buildings and Facilities; Architectural Barriers Act (ABA) Accessibility Guidelines; current edition.
- B. 39 CFR 111 - U.S. Postal Service Standard 4C; Current Edition.
- C. ADA Standards - 2010 ADA Standards for Accessible Design; 2010.

**1.04 SUBMITTALS**

- A. See Section 013000 - Administrative Requirements, for submittal procedures.
- B. Product Data: Provide manufacturer's specifications and descriptive literature, installation instructions, maintenance information, and current USPS approval documentation.
- C. Shop Drawings: Indicate plans for each unit or groups of units, front elevations with compartment layout and model number, overall dimensions, rough-in opening sizes, construction and anchorage details.

**1.05 WARRANTY**

- A. See Section 017800 - Closeout Submittals, for additional warranty requirements.
- B. Provide manufacturer's warranty against defects in materials or workmanship for a period of 5 years from Date of Substantial Completion.

**PART 2 PRODUCTS**

**2.01 CENTRAL MAIL DELIVERY BOXES**

- A. Manufacturers:
  - 1. Salsbury Industries: [www.mailboxes.com/#sle](http://www.mailboxes.com/#sle).
  - 2. Substitutions: See Section 016000 - Product Requirements.
- B. Central Mail Delivery Boxes: Provide products approved for United States Postal Service (USPS) delivery.
  - 1. Materials: Aluminum with stainless steel hardware.
  - 2. Finish: Powder coat in color selected by Architect from manufacturer's standard colors.
  - 3. Unit Types and Sizes: As indicated on drawings.
  - 4. Configurations: See drawings for overall dimensions and layouts.
- C. Cluster Box Units (CBU): Pedestal-mounted, mail receptacle with weather-resistant cabinet for outdoor installation; front-loading, double-column design.
  - 1. Unit A: 15 customer compartments (3 inch high), 1 outgoing mail receptacle, and 3 parcel compartments.
    - a. Salsbury Industries; Model 3816D-15.

**2.02 COMPONENTS**

- A. Locking - Front Loading Master Door: Three-point latching mechanism with USPS master lock furnished and installed by postmaster.
- B. Locking - Customer Compartment Doors: USPS approved cam lock, 3 keys each lock.
- C. Locking - Parcel Compartment Doors: Double-lock arrangement with USPS approved cam lock for customer access, and USPS master lock furnished and installed by postmaster.

- D. Pedestals: Standard aluminum pedestal with rubber mounting pad designed to meet USPS and height requirements of ADA Standards.
- E. Identification - Customer and Parcel Compartments: Sequential numerical or alphabetic characters, top to bottom, left to right; factory-installed.

### **PART 3 EXECUTION**

#### **3.01 EXAMINATION**

- A. Verify that concrete base and anchor bolts are ready to receive pedestal-mounted units.
- B. Verify that rough-openings are ready to receive wall-mounted units.
- C. Do not begin installation until unacceptable conditions are corrected.

#### **3.02 INSTALLATION**

- A. Install postal specialties in accordance with approved shop drawings, manufacturer's instructions, and USPS requirements.
- B. Adjust and lubricate door hardware to operate properly.
- C. Install mailbox identification items.

**END OF SECTION**

**SECTION 105723  
CLOSET AND UTILITY SHELVING**

**PART 1 GENERAL**

**1.01 SECTION INCLUDES**

- A. Wall mounted wire closet shelving.
- B. Accessories.

**1.02 RELATED REQUIREMENTS**

- A. Section 061000 - Rough Carpentry: Blocking in walls for attachment of shelving or storage system.
- B. Section 092116 - Gypsum Board Assemblies: Blocking in metal stud walls for attachment of standards or mounting rails.

**1.03 SUBMITTALS**

- A. See Section 013000 - Administrative Requirements, for submittal procedures.
- B. Product Data: Manufacturer's data sheets on each product to be used, with installation instructions.
- C. Shop Drawings: Provide drawings prepared specifically for this project; show dimensions of shelving or storage system and attachment to substrates.
- D. Warranty Documentation: Submit manufacturer warranty and ensure that forms have been completed in Owner's name and registered with manufacturer.

**1.04 QUALITY ASSURANCE**

- A. Manufacturer Qualifications: Company specializing in manufacturing products specified in this section, with not less than five years of documented experience.

**1.05 DELIVERY, STORAGE, AND HANDLING**

- A. Store products in manufacturer's unopened packaging until ready for installation.
- B. Store products under cover and elevated above grade.
- C. Store flat to prevent warpage and bending.

**1.06 FIELD CONDITIONS**

- A. Maintain temperature, humidity, and ventilation within limits recommended by manufacturer. Do not install products under environmental conditions outside manufacturer's limits.

**1.07 WARRANTY**

- A. See Section 017800 - Closeout Submittals for additional warranty requirements.

**PART 2 PRODUCTS**

**2.01 MANUFACTURERS**

- A. Wire Storage Shelving:
  - 1. ClosetMaid Corporation; Fixed Wire Shelving: [www.closetmaidpro.com/#sle](http://www.closetmaidpro.com/#sle).
  - 2. Substitutions: See Section 016000 - Product Requirements.

**2.02 WIRE STORAGE SHELVING SYSTEMS**

- A. Applications:
  - 1. Bedroom/Coat Closet: One piece continuous, wall-to-wall shelf & hanging rod.
    - a. Product: Total Slide #591801
    - b. Shelf Depth: 16" ventilated shelf
    - c. Hanging Rod: 9/32" diameter hanging rod
  - 2. Pantry Closets: One piece continuous, wall-to-wall shelves
    - a. Product: Close Mesh Shelving #403
    - b. Shelf Depth: 20" ventilated shelf
    - c. Number of Shelves: (5) Five

- B. Wire Shelving: Factory-assembled coated wire mesh shelf assemblies for wall-mounting, with components and connections required to produce a rigid structure that is free of buckling and warping.
  - 1. Construction: Cold-drawn steel wire with average tensile strength of 100,000 psi (690 MPa) resistance welded into uniform mesh units, square, rigid, flat, and free of dents or other distortions, with wires trimmed smooth.
  - 2. Coating: PVC, applied after fabrication, covering surfaces.
  - 3. PVC Coating: 9-17 mills thick.
  - 4. Close-Mesh Shelves: Cross deck wires spaced at 5/8 inch.
  - 5. Hanging Rod: Hanging rod at front edge of shelf.
  - 6. Corner Units: Same wire spacing as standard mesh shelves; provide wherever shelves meet at right angles.
- C. Mounting Hardware for Wire Shelving: Provide manufacturer's standard mounting hardware; include support braces, wall brackets, standards, back clips, end clips, poles, and other accessories as required for complete and secure installation; factory finished to match shelving.
- D. Support brackets shall be required for 36 inch span. Wall clips are required 1 inch from each end and every 10 inch to 12 inch in between.
- E. Fasteners: As recommended by manufacturer for mounting substrates.

### **PART 3 EXECUTION**

#### **3.01 EXAMINATION**

- A. Inspect areas to receive shelving or storage system, to verify that spaces are properly prepared to receive shelf units, and are of dimensions indicated on shop drawings.
- B. Verify appropriate fastening hardware.
- C. Do not begin installation until substrates have been properly prepared.
- D. If substrate preparation is the responsibility of another installer, notify Architect of unsatisfactory preparation before proceeding.

#### **3.02 PREPARATION**

- A. Clean surfaces thoroughly prior to installation.
- B. Prepare surfaces using the methods recommended by the manufacturer for achieving the best result for the substrate under the project conditions.

#### **3.03 INSTALLATION**

- A. Install wire shelving in accordance with manufacturer's instructions, with shelf surfaces level.
- B. Cap exposed ends of cut wire shelving.
- C. Install wire shelving back clips, end clips at side walls, and support braces at open ends. Install intermediate support braces as recommended by manufacturer.
- D. Wire Shelving Mounting Heights:
  - 1. As noted on drawings.

#### **3.04 CLEANING**

- A. Clean soiled surfaces after installation.

#### **3.05 PROTECTION**

- A. Protect installed work from damage.
- B. Touch-up, repair, or replace damaged products before Substantial Completion in a manner that eliminates evidence of replacement.

**END OF SECTION**



**SECTION 113013  
RESIDENTIAL APPLIANCES**

**PART 1 GENERAL**

**1.01 SECTION INCLUDES**

- A. Kitchen appliances.

**1.02 RELATED REQUIREMENTS**

- A. Section 260583 - Wiring Connections: Electrical connections for appliances.

**1.03 REFERENCE STANDARDS**

- A. UL (DIR) - Online Certifications Directory; Current Edition.

**1.04 SUBMITTALS**

- A. See Section 013000 - Administrative Requirements, for submittal procedures.
- B. Product Data: Manufacturer's data indicating dimensions, capacity, and operating features of each piece of residential equipment specified.
- C. Copies of Warranties: Submit manufacturer warranty and ensure that forms have been completed in Owner's name and registered with manufacturer.

**1.05 QUALITY ASSURANCE**

- A. Manufacturer Qualifications: Company specializing in manufacturing products specified in this section, with not less than three years of documented experience.
- B. Electric Appliances: Listed and labeled by UL (DIR) and complying with NEMA Standards (National Electrical Manufacturers Association).
- C. Gas Appliances: Bearing design certification seal of American Gas Association (AGA).

**1.06 WARRANTY**

- A. See Section 017800 - Closeout Submittals, for additional warranty requirements.
- B. Provide five (5) year manufacturer warranty on refrigeration system of refrigerators.
- C. Provide ten (10) year manufacturer warranty on magnetron tube of microwave ovens.

**PART 2 PRODUCTS**

**2.01 KITCHEN APPLIANCES**

- A. Provide Equipment Eligible for Energy Star Rating: Energy Star Rated.
- B. Refrigerator: Free-standing, top-mounted freezer, and frost-free.
  - 1. Capacity: Total minimum storage of 16.6 cubic ft (\_\_\_\_ cu m); minimum 15 percent freezer capacity.
  - 2. Energy Usage: Minimum 20 percent more energy efficient than energy efficiency standards set by U.S. Department of Energy (DOE).
  - 3. Features: Include light in freezer compartment.
  - 4. Exterior Finish: White, color as indicated.
  - 5. Manufacturers:
    - a. GE Appliances; GTE17DTNRWW: [www.geappliances.com/#sle](http://www.geappliances.com/#sle).
    - b. Substitutions: See Section 016000 - Product Requirements.
- C. Range: Electric, free-standing, with plug-in heating elements and removable drip pans.
  - 1. Size: 30 inches (762 mm) wide.
  - 2. Oven: Self-cleaning with electronic ignition.
  - 3. Elements: Four (4).
  - 4. Controls: Solid state electronic.
  - 5. Features: Include storage drawer, broiler pan and grid, and oven light.
  - 6. Exterior Finish: White, color as indicated.
  - 7. Provide anti-tilt anchor at rear of all ranges and anchor to wall.
  - 8. Manufacturers:

- a. GE Appliances: [www.geappliances.com/#sle](http://www.geappliances.com/#sle).
    - 1) ADA - Model #JD630DTWW
    - 2) Standard - Model #JBS160DMWW
  - b. Substitutions: See Section 016000 - Product Requirements.
- D. Cooking Exhaust: Range hood.
- 1. Size: 30 inches (762 mm) wide.
  - 2. Fan: Two-speed, 270 cfm (\_\_\_\_ L/s)
  - 3. Exhaust: Rectangular, vented to exterior.
  - 4. Features: Include cooktop light and removable grease filter.
  - 5. Exterior Finish: White, color as indicated.
  - 6. Manufacturers:
    - a. GE Appliances: [www.geappliances.com/#sle](http://www.geappliances.com/#sle).
      - 1) Standard - JVM3160DFWW
      - 2) ADA - JVX3300DJWW
    - b. Substitutions: See Section 016000 - Product Requirements.
- E. Microwave: Countertop and Over-the-Range.
- 1. Capacity: 1.6-2.2 cubic ft (\_\_\_\_ cu m).
  - 2. Power: 1000-1100 watts.
  - 3. Features: Include turntable and 2-speed exhaust fan.
  - 4. Exterior Finish: White.
  - 5. Manufacturers:
    - a. GE Appliances: [www.geappliances.com/#sle](http://www.geappliances.com/#sle).
      - 1) Standard - JVM3160DFWW
      - 2) ADA - PEB7227DLWW
    - b. Substitutions: See Section 016000 - Product Requirements.

## **PART 3 EXECUTION**

### **3.01 EXAMINATION**

- A. Verify utility rough-ins are provided and correctly located.

### **3.02 INSTALLATION**

- A. Install in accordance with manufacturer's instructions.
- B. Anchor built-in equipment in place.
- C. Provide tilt prevention anchors for all ranges and anchor to wall behind range.
- D. Remove all existing appliances and dispose of, legally, off-site.

### **3.03 ADJUSTING**

- A. Adjust equipment to provide efficient operation.

### **3.04 CLEANING**

- A. Remove packing materials from equipment and properly discard.
- B. Wash and clean equipment.

**END OF SECTION**

**SECTION 122113  
HORIZONTAL LOUVER BLINDS**

**PART 1 GENERAL**

**1.01 SECTION INCLUDES**

- A. Horizontal slat louver blinds.
- B. Operating hardware.

**1.02 RELATED REQUIREMENTS**

- A. Section 061000 - Rough Carpentry: Concealed wood blocking for attachment of headrail brackets.

**1.03 SUBMITTALS**

- A. See Section 013000 - Administrative Requirements, for submittal procedures.
- B. Product Data: Provide data indicating physical and dimensional characteristics.
- C. Slat Color Samples: Submit full range of colors available from manufacturer's standard colors.
- D. Manufacturer's Installation Instructions: Indicate special procedures.
- E. Maintenance Materials: Furnish the following for Owner's use in maintenance of project.
  - 1. See Section 016000 - Product Requirements, for additional provisions.
  - 2. Extra Lift Cords, Control Cords, and Wands: 5% of material installed.

**1.04 QUALITY ASSURANCE**

- A. Manufacturer Qualifications: Company specializing in manufacturing the products specified in this section with minimum five years documented experience.

**PART 2 PRODUCTS**

**2.01 MANUFACTURERS**

- A. Horizontal Louver Blinds:
  - 1. SWFcontract, a division of Springs Window Fashions, LLC: [www.swfcontract.com/#sle](http://www.swfcontract.com/#sle).
  - 2. Substitutions: See Section 016000 - Product Requirements.
- B. Source Limitations: Furnish blinds and associated controls produced by a single manufacturer and obtained from a single supplier.

**2.02 VINYL BLINDS**

- A. Description: Horizontal slat louvers hung from full-width headrail with full-width bottom rail and side guides for slat stability.
- B. Manual Operation: Control of raising, lowering, and tilting blades by crank operator. Gear box concealed in headrail; fixed handle.
- C. Product.
  - 1. SWF Contract 2" Designer Vinyl Blinds
  - 2. Product Rep. Candy McDowall @ KMA Associates (614) 226-2252 (email) [cmcdowall@kma.bz](mailto:cmcdowall@kma.bz)
  - 3. Specifications:
    - a. Slats: Shall be rigid, UV-stabilized, crowned PVC nominally 2" wide by .045" thick with straight-cut edges. Slats meet the requirement of NFPA 701 Test Method 1-2004 edition.
    - b. SureClose Headrail: Shall be 1 5/8" high by 2 1/4" wide by .022" thick U-shaped steel with 1/8" light blocking lip on the bottom center line. The steel finishing process includes phosphate treatment for corrosion resistance, a chrome-free sealer, a low HAP urethane primer, and a topcoat of low HAP, polyester-baked enamel.
    - c. Bottomrail: Shall be extruded foam PVC 9/16" high x 2" wide and shall coordinate with the slats.
    - d. Lift Cord: 100% polyester yarn and 1.8mm thick for standard routes. Cord shall be compliant with ANSI WCMA A100.1-2018 standard for cord length.

- e. Tilt Rod: Shall be electro-zinc coated solid steel measuring 1/4" square.
- f. Drums: Shall be made of high-strength thermoplastic, which securely anchors braided ladder.
- g. Braided Ladder: Shall be made of 100% polyester yarn, incorporating two extra-strength rungs per ladder to support slats. Standard ladder spacing shall be 44 mm.
- h. Installation Brackets: Shall be a universal style with hinged front cover, made of phosphate-treated steel with urethane primer and polyester-baked enamel finish to match headrail.
- i. Hardware: Type recommended by manufacturer.

### **2.03 FABRICATION**

- A. Determine sizes by field measurement.
- B. Blinds to have "light gap" between blind and window frame.

## **PART 3 EXECUTION**

### **3.01 EXAMINATION**

- A. Verify that openings are ready to receive the work.
- B. Ensure structural blocking and supports are correctly placed. See Section 061000.

### **3.02 INSTALLATION**

- A. Install blinds in accordance with manufacturer's instructions.
- B. Secure in place with flush countersunk fasteners.

### **3.03 ADJUSTING**

- A. Adjust blinds for smooth operation.

### **3.04 CLEANING**

- A. Clean blind surfaces just prior to occupancy.

**END OF SECTION**

**SECTION 123530  
RESIDENTIAL CASEWORK**

**PART 1 GENERAL**

**1.01 SECTION INCLUDES**

- A. Kitchen Cabinets.
- B. ADA Compliant Vanity Cabinets.

**1.02 RELATED REQUIREMENTS**

- A. Section 079200 - Joint Sealants: Sealing joints between casework and countertops and adjacent walls, floors, and ceilings.
- B. Section 123600 - Countertops.

**1.03 REFERENCE STANDARDS**

- A. ANSI A208.1 - American National Standard for Particleboard; 2022.
- B. BHMA A156.9 - Cabinet Hardware; 2020.
- C. KCMA A161.1 - Performance and Construction Standard for Kitchen and Vanity Cabinets; 2017.
- D. NEMA LD 3 - High-Pressure Decorative Laminates; 2005.

**1.04 SUBMITTALS**

- A. See Section 013000 - Administrative Requirements, for submittal procedures.
- B. Product Data: Provide component dimensions, configurations, construction details, and joint details.
- C. Certificate: Submit Kitchen Cabinet Manufacturers Association (KCMA) certificate showing conformance with KCMA A161.1.
- D. Certificate: Submit Kitchen Cabinet Manufacturers Association (KCMA) certificate showing manufacturer has met the requirements of KCMA's Environmental Stewardship Program (ESP).
- E. Shop Drawings: Indicate casework locations, elevations, clearances required, rough-in and anchor placement dimensions and tolerances.
- F. Cabinet Finish Sample: Submit two samples of each type of finish, 2 inches by 3 inches (51 mm by 75 mm) in size, illustrating color, texture, gloss, and wood species.
- G. Manufacturer's Qualification Statement.
- H. Warranty Documentation: Submit manufacturer warranty and ensure that forms have been completed in Owner's name and registered with manufacturer.

**1.05 QUALITY ASSURANCE**

- A. Products: Cabinets complying with requirements of KCMA's Environmental Stewardship Program (ESP).
- B. Manufacturer: Company specializing in manufacturing the type of products specified in this section, with minimum five years of documented experience.

**1.06 WARRANTY**

- A. See Section 017800 - Closeout Submittals, for additional warranty requirements.
- B. Manufacturer limited 5 year warranty.

**PART 2 PRODUCTS**

**2.01 CABINETS**

- A. Manufacturers:
  - 1. Smart Cabinetry; [www.smartcabinetry.com/#sle..](http://www.smartcabinetry.com/#sle..)
- B. Kitchen and Vanity Cabinets: Premanufactured and factory-finished, complying with construction and testing requirements in KCMA A161.1.

- C. Cabinet Box: Standard Particleboard Construction
  - 1. Wall and Base Backs: 1/2" nominal particleboard with light maple laminate interior. Wall backs are stapled and glued into rabbeted ends.
  - 2. Wall and Base Sides: 1/2" nominal with light maple laminate interior and designated laminated exterior.
  - 3. Base Bottoms: 1/2" nominal particleboard with light maple laminate interiors. Bottoms are hot melt glued into dados on all four sides.
  - 4. Wall Tops and Bottoms: 1/2" nominal particleboard with light maple laminate, hot melt glued into dados on all four sides.
  - 5. I-Beam Construction Rails: 1/2" nominal particleboard. Rails are hot melt glued into face frame, sides, and cabinet back.
  - 6. Toe Kicks: 3 1/2" deep by 4 1/2" tall. Finish to match cabinets.
  - 7. Interior Cabinet Finish: Manuf. standard light maple wood grain laminate.
- D. Cabinet Door/Drawer Configuration: Standard Overlay.
- E. Cabinet Doors:
  - 1. Style: Rockport manufactured by Smart Cabinetry.
  - 2. Solid wood, stained finish.
  - 3. Stain Color: As indicated on drawings..
- F. Drawers:
  - 1. Solid wood sides with dovetail joints, 1/4" nominal matching laminate bottom panel.
  - 2. Drawer Front: To match cabinet doors in style, material, and finish.
  - 3. Interior Finish: Manuf. standard light maple wood grain laminate.
- G. Shelves: Manufacturer's standard 3/4" edgebanded adjustable shelves and shelf supports.
- H. Cabinet Hardware:
  - 1. Drawer and Cabinet Pulls: Amerock Allison Value, Item No. AME-129053.
    - a. Centers: 3"
    - b. Length: 4 1/16"
    - c. Projection: 3/4"
    - d. Finish: Satin Nickel
  - 2. Hinges: Manufacturer's standard 6-way adjustable hinges, heavy duty, self-closing, and concealed within the cabinet door and frame.
  - 3. Drawer Slides: Manufacturer's standard 75 lb. load rated, epoxy coated slides.
- I. Countertops: As specified in Section 123600.

## **2.02 WALL HUNG VANITY CABINET**

- A. Manufacturers:
  - 1. Smart Cabinetry: [www.smartcabinetry.com](http://www.smartcabinetry.com)
  - 2. Substitutions: See Section 016000 - Product Requirements.
- B. Wall Hung Vanity:
  - 1. Style: Rockport. To match cabinet style in kitchens.
  - 2. Wood Species: Maple
  - 3. Finish: Silvergrass
  - 4. Dimensions: 24" deep by 23 1/2" high
  - 5. Installation Height: As shown on drawings.
  - 6. Components: Matching removable panel with clips. Provided additional support as recommended by manufacturer.
- C. Countertop: As specified in Section 123600.
- D. Location: ADA Units Bathroom

## **2.03 MATERIALS**

- A. Wood-Based Materials:

1. Solid Wood: Air-dried to 4.5 percent moisture content, then tempered to 6 percent moisture content before use.
- B. Solid Wood: Clear, dry, sound, plain sawn, selected for species grain and color, no defects.
- C. Particleboard: Composed of wood chips, medium density, with waterproof resin binders; of grade to suit application; sanded faces; complying with ANSI A208.1.
- D. Thermally Fused Laminate (TFL): Melamine resin, NEMA LD 3, Type VGL laminate panels.

#### **2.04 FABRICATION**

- A. Shop assemble casework for delivery to site in units easily handled and to permit passage through building openings.
- B. Fabricate corners and joints without gaps.
- C. Fabricate each unit to be rigid and not dependent on adjacent units for rigidity.
- D. Provide cutouts for plumbing fixtures and appliances. Prime paint contact surfaces of cut edges.

### **PART 3 EXECUTION**

#### **3.01 EXAMINATION**

- A. Verify adequacy of support framing.

#### **3.02 INSTALLATION**

- A. Install casework, components and accessories in accordance with manufacturer's instructions.
- B. Set casework items plumb and square, securely anchored to building structure.

#### **3.03 ADJUSTING**

- A. Adjust doors, drawers, hardware, and other moving or operating parts to function smoothly.

#### **3.04 CLEANING**

- A. Clean casework, countertops, shelves, and hardware.

#### **3.05 PROTECTION**

- A. Do not permit finished casework to be exposed to continued construction activity.

**END OF SECTION**

## **SECTION 123600 COUNTERTOPS**

### **PART 1 GENERAL**

#### **1.01 SECTION INCLUDES**

- A. Countertops for residential casework.
- B. Wall-hung counters.

#### **1.02 RELATED REQUIREMENTS**

- A. Section 123530 - Residential Casework.

#### **1.03 REFERENCE STANDARDS**

- A. ANSI A137.3 - American National Standard Specifications for Gauged Porcelain Tile and Gauged Porcelain Tile Panels/Slabs; 2021.
- B. ANSI A208.1 - American National Standard for Particleboard; 2022.
- C. ASTM C373 - Standard Test Methods for Determination of Water Absorption and Associated Properties by Vacuum Method for Pressed Ceramic Tiles and Glass Tiles and Boil Method for Extruded Ceramic Tiles and Non-tile Fired Ceramic Whiteware Products; 2018 (Reapproved 2023).
- D. AWI (QCP) - Quality Certification Program; Current Edition.
- E. AWI/AWMAC/WI (AWS) - Architectural Woodwork Standards, 2nd Edition; 2014, with Errata (2016).
- F. AWMAC/WI (NAAWS) - North American Architectural Woodwork Standards; 2021, with Errata.
- G. ISFA 2-01 - Classification and Standards for Solid Surfacing Material; 2013.
- H. NEMA LD 3 - High-Pressure Decorative Laminates; 2005.

#### **1.04 SUBMITTALS**

- A. See Section 013000 - Administrative Requirements for submittal procedures.
- B. Product Data: Manufacturer's data sheets on each product to be used, including:
  - 1. Preparation instructions and recommendations.
  - 2. Storage and handling requirements and recommendations.
  - 3. Specimen warranty.
- C. Shop Drawings: Complete details of materials and installation ; combine with shop drawings of cabinets and casework specified in other sections.
- D. Verification Samples: For each finish product specified, minimum size 6 inches (150 mm) square, representing actual product, color, and patterns.
- E. Certificate: Submit labels and certificates required by quality assurance and quality control programs.
- F. Installer's qualification statement.
- G. Installation Instructions: Manufacturer's installation instructions and recommendations.
- H. Maintenance Data: Manufacturer's instructions and recommendations for maintenance and repair of countertop surfaces.

#### **1.05 QUALITY ASSURANCE**

- A. Installer Qualifications: Company specializing in performing work of the type specified in this section, with not less than five years of documented experience.
- B. Quality Certification:
  - 1. Comply with AWI (QCP) woodwork association quality certification service/program in accordance with requirements for work specified in this section: [www.awiqcp.org/#sle](http://www.awiqcp.org/#sle).
  - 2. Provide labels or certificates indicating that the installed work complies with AWI/AWMAC/WI (AWS) or AWMAC/WI (NAAWS) requirements for grade or grades



specified.

3. Provide designated labels on shop drawings as required by certification program.
4. Provide designated labels on installed products as required by certification program.
5. Submit certifications upon completion of installation that verifies this work is in compliance with specified requirements.

#### **1.06 DELIVERY, STORAGE, AND HANDLING**

- A. Store products in manufacturer's unopened packaging until ready for installation.
- B. Store and dispose of solvent-based materials, and materials used with solvent-based materials, in accordance with requirements of local authorities having jurisdiction.

#### **1.07 FIELD CONDITIONS**

- A. Maintain environmental conditions (temperature, humidity, and ventilation) within limits recommended by manufacturer for optimum results. Do not install products under environmental conditions outside manufacturer's absolute limits.

### **PART 2 PRODUCTS**

#### **2.01 COUNTERTOPS**

- A. Quality Standard: Custom Grade, in accordance with AWI/AWMAC/WI (AWS) or AWMAC/WI (NAAWS), unless noted otherwise.
- B. Plastic Laminate Countertops: High-pressure decorative laminate (HPDL) sheet bonded to substrate.
  1. Laminate Sheet: NEMA LD 3, Grade HGP, for postforming, 0.048 inch (1.2 mm) nominal thickness.
    - a. Manufacturers:
      - 1) Formica Corporation: [www.formica.com/#sle](http://www.formica.com/#sle).
      - 2) Panolam Industries International, Inc: [www.panolam.com/#sle](http://www.panolam.com/#sle).
      - 3) Wilsonart{CH#121508}: [www.wilsonart.com/#sle](http://www.wilsonart.com/#sle).
    - b. Finish: Matte or suede, gloss rating of 5 to 20.
    - c. Surface Color and Pattern: As indicated on drawings.
  2. Exposed Edge Treatment: Postformed laminate; front edge substrate built up to minimum 1 1/2" inch (38 mm) thick with radiused edge, integral coved backsplash with radiused top edge.
  3. End Splashes: Same material, same construction.
- C. Cultured Marble Tops:
  1. Integral rectangular bowl single sink 3-hole
    - a. Manufacturers:
      - 1) Wolf Vanity Tops: [www.wolfhomeproducts.com/#sle](http://www.wolfhomeproducts.com/#sle).
      - 2) Wyndham Collection (Sold at home improvement retailers)
      - 3) Project Source (Sold at home improvement retailers)
      - 4) Glacier Bay (Sold at home improvement retailers)
      - 5) Substitutions: See Section 016000 - Product Requirements.
    - b. Dimensions:
      - 1) 30"w x 22" deep (ADA compliant)
      - 2) 36"w x 22" deep
    - c. Thickness: 3/4"
    - d. Integrated backsplash
    - e. Matching sidesplash
    - f. Color(s): As indicated on drawings.

#### **2.02 MATERIALS**

- A. Wood-Based Components:
  1. Wood fabricated from old growth timber is not permitted.
- B. Particleboard for Supporting Substrate: ANSI A208.1 Grade 2-M-2, 45 pcf (20 kg/cu m) minimum density; minimum 3/4 inch (19 mm) thick; join lengths using metal splines.

- C. Adhesives: Chemical resistant waterproof adhesive as recommended by manufacturer of materials being joined.
- D. Joint Sealant: Mildew-resistant silicone sealant, white.

### **2.03 ACCESSORIES**

- A. Concealed Countertop Support Brackets:
  - 1. Material: Steel.
  - 2. Finish: Clear Anodi
  - 3. Products:
    - a. RAKKS Concealed EH-1818 Countertop Support Bracket.
    - b. Substitutions: See Section 016000 - Product Requirements.

### **2.04 FABRICATION**

- A. Fabricate tops and splashes in the largest sections practicable, with top surface of joints flush.
  - 1. Join lengths of tops using best method recommended by manufacturer.
  - 2. Fabricate to overhang fronts and ends of cabinets 1 inch (25 mm) except where top butts against cabinet or wall.
  - 3. Prepare all cutouts accurately to size; replace tops having improperly dimensioned or unnecessary cutouts or fixture holes.
- B. Wall-Mounted Counters: Provide skirts, aprons, brackets, and braces as indicated on drawings, finished to match.

## **PART 3 EXECUTION**

### **3.01 EXAMINATION**

- A. Do not begin installation until substrates have been properly prepared.
- B. If substrate preparation is the responsibility of another installer, notify Architect of unsatisfactory preparation before proceeding.
- C. Verify that wall surfaces have been finished and mechanical and electrical services and outlets are installed in proper locations.

### **3.02 PREPARATION**

- A. Clean surfaces thoroughly prior to installation.
- B. Prepare surfaces using the methods recommended by the manufacturer for achieving the best result for the substrate under the project conditions.

### **3.03 INSTALLATION**

- A. Install vanities in accordance with manufacturer's instructions and approved shop drawings
- B. Securely attach countertops to cabinets using concealed fasteners. Make flat surfaces level; shim where required.
- C. Attach plastic laminate countertops using screws with minimum penetration into substrate board of 5/8 inch (16 mm).
- D. Seal joint between back/end splashes and vertical surfaces.

### **3.04 CLEANING**

- A. Clean countertops surfaces thoroughly.

### **3.05 PROTECTION**

- A. Protect installed products until completion of project.
- B. Touch-up, repair or replace damaged products before Date of Substantial Completion.

**END OF SECTION**

**SECTION 142123  
ELECTRIC TRACTION PASSENGER ELEVATORS**

**PART 1 – GENERAL**

**1.01 SECTION INCLUDES**

- A. Electric traction passenger elevators.

**1.02 RELATED SECTIONS**

- A. Section 015000 – Temporary Facilities and Controls: Protection of floor openings and personnel barriers; temporary power and lighting.
- B. Section 033000 – Cast-in-Place Concrete: Elevator pits.
- C. Section 042000 – Masonry Units (Unit Masonry): Setting sleeves, inserts, and anchoring devices in masonry for guide-rail brackets.
- D. Section 099000 – Paints and Coatings (Painting and Coating): Field painting of elevator entrances over primer.
- E. Section 283100 – Detection and Alarm (Fire Detection and Alarm): Heat, smoke, and products of combustion sensing devices, fire alarm signal lines to contacts in machine space.
- F. Section 23000 – Heating, Ventilating, and Air Conditioning Equipment (Heating, Ventilating, and Air-Conditioning (HVAC)): Heating, cooling, and ventilation of control and machinery space.
- G. Section 260500 – Wiring Methods (Common Work Results for Electrical): Light outlets, convenience outlets, light switches, and conduits.
- H. Section 262400 – Switchboards, Panelboards, and Control Centers (Switchboards and Panelboards): Disconnect switches.
- I. Section 265000 – Lighting: Light fixtures.
- J. Section 221429 – Sump Pumps: For sump pumps, sumps, and sump covers in elevator pits.
- K. Section 271500 – Communications Horizontal Cabling: For Telephone service for elevators and for Internet connection to elevator controllers for remote monitoring.
- L. Section 273000 – Telephone and Intercommunication Equipment (Voice Communications): Telephone outlets and elevator telephones.
- M. Section 31000 – Earthwork: Excavation of elevator pit.

**1.03 REFERENCES**

- A. ANSI/ASME A17.1/CAN/CSA B44 – Safety Code for Elevators and Escalators.
- B. ADAAG – Americans with Disabilities Act Accessibility Guidelines.
- C. ANSI/NFPA 70 – National Electrical Code.
- D. ANSI/NFPA 80 – Fire Doors and Windows.
- E. ANSI/UL 10B – Fire Tests of Door Assemblies.
- F. CAN/CSA C22.1 – Canadian Electrical Code.
- G. Model and Local Building CodesH. ISO 9001: 2000 - Quality Management Systems - Requirements.

**1.04 DESIGN REQUIREMENTS**

- A. Arrange elevator components in control closet or machinery space so equipment can be removed for repairs or replaced with minimal disturbance to other equipment and components.
- B. Where permitted by code, provide all elevator equipment including controls, drives, transformers, and rescue features within the elevator hoistway.

**1.05 SUBMITTALS**

- A. Comply with Section 013300 (01 33 00) – Submittal Procedures.

- B. Product Data: Submit manufacturer/installer's product data, including,
  1. Descriptive brochures or detail drawings of car and hall fixtures, cab ceilings, and product features.
  2. Power Information: Horsepower, starting current, running current, machine and control heat release, and electrical requirements.
- C. Shop Drawings: Submit manufacturer/installer's shop drawings, including plans, elevations, sections, and details, indicating location of equipment, loads, dimensions, tolerances, materials, components, fabrication, fasteners, hardware, finish, options, accessories, and other information to render totally functional elevators.
- D. Samples: Submit manufacturer/installer's samples of standard colors and finishes of finish materials.
- E. Operation and Maintenance Manual: Submit manufacturer/installer's operation and maintenance manual; including operation, maintenance, adjustment, and cleaning instructions; trouble shooting guide; renewal parts catalogs; and electrical wiring diagrams.
- F. Warranty: Submit manufacturer/installer's standard warranty.

#### **1.06 QUALITY ASSURANCE**

- A. Manufacturer/Installer's Qualifications: Specialize in manufacturing and installing elevator equipment, with a minimum of 10 years successful experience.
- B. Regulatory Requirements:
  1. Elevator design, clearances, construction, workmanship, materials, and installation, unless specified otherwise, shall be in accordance with ANSI/ASME A17.1, handicap accessibility, Americans with Disabilities Act, and other codes having legal jurisdiction.
  2. ANSI/ASME A17.1 shall govern, except where codes having legal jurisdiction include more rigid requirements or conflict with ANSI/ASME A17.1.
  3. Elevator shall follow design and manufacturing procedures certified in accordance with ISO 9001-2000 to meet product and service requirements for quality assurance for new products.
  4. Where product is in variance to the published ANSI/ASME A17.1 model code, provide a 3rd party AECO certification demonstrating equivalent function, safety, and performance.
- C. Pre-installation Meeting:
  1. Convene pre-installation meeting before start of installation of elevators.
  2. Require attendance of parties directly affecting work of this section, including Contractor, Architect, and elevator manufacturer/installer.
  3. Review examination, installation, field quality control, adjusting, cleaning, protection, and coordination with other work.

#### **1.07 DELIVERY, STORAGE, AND HANDLING**

- A. Delivery: Deliver materials to site in manufacturer/installer's original, unopened containers and packaging, with labels clearly identifying product name and manufacturer/installer.
- B. Storage: Store materials in clean, dry area indoors in accordance with manufacturer/installer's instructions.
- C. Handling: Protect materials during handling and installation to prevent damage.

#### **1.08 PROJECT CONDITIONS**

- A. Temporary Electrical Power:
  1. Contractor may use power from existing building as needed.
  2. Comply with Section 015100 – Temporary Utilities.
- B. Installation of the Elevator:
  1. General Contractor will provide permanent three-phase power prior to installation start.
  2. General Contractor will provide clear, rollable access to a 20' x 10' secure and dry storage area prior to delivery.

3. General Contractor will provide a clean, dry, and complete hoistway along with temporary installation platform and all required OSHA-compliant barricades prior to delivery.

#### **1.09 SCHEDULING**

- A. Coordinate elevator work with work of other trades, for proper time and sequence to avoid construction delays.
- B. Coordinate elevator work with owner to ensure Contractor to meet Owner's scheduling requirements.

#### **1.10 WARRANTY**

- A. Manufacturer/installer shall guarantee materials and workmanship of equipment installed under these specifications and make good, defects not due to ordinary wear or to improper use, which may develop within 1 year after Project's substantial completion date.

#### **1.11 MAINTENANCE SERVICE**

- A. Elevator maintenance service shall be performed by elevator manufacturer/installer.
- B. Elevators shall receive regular maintenance on each unit for period of 12 months after completion of work specified herein or acceptance thereof by beneficial use, whichever is earlier.
- C. Trained employees shall make periodic examinations and perform work including necessary adjusting, greasing, oiling, and replacing parts to keep elevators in operation, except parts that require replacement because of vandalism, misuse, or negligence by parties other than manufacturer/installer.
- D. Manufacturer/installer shall perform all Work, except emergency minor adjustment call-back service, during regular working hours. Manufacturer/installer shall provide emergency minor adjustment call-back service, during regular working hours at no additional cost to the Owner.
- E. Elevator Control System:
  1. Include built-in remote diagnostic module to relay constant status of elevators and control system to a 24-hour, 7-days-a-week central-monitoring facility.
  2. Remote Monitoring Device: Transmit information on current status of elevators, including malfunctions, system errors, and shutdown.

### **PART 2 – PRODUCTS**

#### **2.01 MANUFACTURER/INSTALLER**

- A. Schindler Elevator Corporation; [www.us.schindler.com](http://www.us.schindler.com).
- B. Alliance Elevator Solutions; [www.allianceelevator.net](http://www.allianceelevator.net)
- C. Otis Elevator Company; [www.otis.com/#sle](http://www.otis.com/#sle).
- D. TK Elevator Corporation; [www.tkelevator.com/us](http://www.tkelevator.com/us)
- E. Elevator shall be installed by elevator manufacturer.
- F. Should not be site sourced.

#### **2.02 ELEVATOR SYSTEM AND COMPONENTS**

- A. Electric Traction Passenger Elevators: Basis of design is the Schindler 3100 Gearless Traction Elevator.
- B. Elevator Equipment Summary:
  1. Application: Machine Room Less (MRL)
  2. Counterweight Location: Side
  3. Machine Location: Top of the hoistway mounted on car and counterweight guide rails
  4. Control Space Location: Top landing entrance frame or entrance frame at one floor below the top landing
  5. Service: General Purpose Passenger
  6. Quantity: 1 Unit
  7. Capacity: 3000 lbs

8. Speed: 100 fpm
  9. Travel: 22' 1 1/4"
  10. Landings: 3
  11. Front Openings: 3
  12. Rear Openings: 0
  13. Rear Door Hand: N/A
  14. Operation: Microprocessor Single Car Automatic Operation
  15. Clear Inside Dimensions: 6' 9-5/16" Wide X 4' 10- 7/8" Deep
  16. Cab Height: 7' 9"
  17. Guide Rails: Equivalent to 12 lb. per foot
  18. Entrance Type and Width: Two Speed CE Opening 3' 6" Wide X 7' 0" High doors
  19. Entrance Height: 7'-0"
  20. Power Supply: 208 Volts 3 Phase 60 Hz
- C. Performance:
1. Car Speed: -10% to +5% of contract speed under any loading condition or direction of travel.
  2. Car Capacity: Safely lower, stop and hold up to 125% of rated load per code.
- D. Ride Quality:
1. Vertical Vibration (maximum): 25 mg
  2. Horizontal Vibration (maximum): 15 mg
  3. Vertical Jerk (maximum): 2 ft/sec<sup>3</sup>
  4. Acceleration (maximum): 1.6 ft/sec<sup>2</sup>
  5. In Car Noise: 53-60 dB(A)
  6. Stopping Accuracy: ±5mm
  7. Starts per hour (maximum): 180
- E. Elevator Operation:
1. Simplex Collective Operation: Using a microprocessor based controller, operation shall be automatic by means of the car and hall buttons. When all calls have been answered, the car shall park at the last landing served.
  2. Group Automatic Operation with Demand-Based Dispatching: Provide reprogrammable group automatic system that assigns cars to hall calls based on a dispatching algorithm designed to minimize passenger waiting time.
- F. Operating Features - Standard:
1. Door Light Curtain Protection
  2. Static AC Drive
  3. Phase Monitor Relay
  4. Cab Overload with Indicator
  5. Load-weighing
  6. Central Alarm
  7. Remote Monitoring
  8. Firefighter's Operation
  9. Automatic Evacuation
    - a. When the main line power is lost for longer than 5 seconds the emergency battery power supply provides power automatically to the elevator controller. If the car is at a floor when the power fails, it remains at that floor, opens its doors, and shuts down. If the car is between floors, it is raised or lowered to the first available landing, opens its doors, and shuts down.
  10. Independent Service

### **2.03 EQUIPMENT: CONTROL COMPONENTS AND CONTROL SPACE**

- A. Controller: Provide microprocessor based control system to perform all of the functions of safe elevator operation, as well as perform car and group operational control.
1. All high voltage (110v or above) contact points inside the inspection and test panel shall be protected from accidental contact in a situation where the access panels are open.

2. The controller shall be distributed throughout the elevator system located in the overhead, cab and inspection and test panel. The inverter will be mounted in the overhead adjacent to the hoist machine and an inspection and test panel will be located in the door jamb at the top floor or one floor below the top floor. No elevator equipment mechanical rooms or closets are required.
  3. Provide multi-bus control architecture to reduce cabling, material and waste.
- B. Drive: Provide a Variable Voltage Variable Frequency AC Closed Loop drive system. Provide stable start without high peak current, quickly reaching a low energy consumption level.
- C. Inspection and Test Panel: Integrated control equipment, main inspection and test panel in door frame at top level served or at one floor below the top level served.

#### **2.04 EQUIPMENT: HOISTWAY COMPONENTS**

- A. Machine:
1. Gearless asynchronous AC motor with integral drive sheave, service and emergency brakes.
  2. Design machine to enable direct power transfer, thereby avoiding loss of power.
  3. Design machine to be compact, lightweight and durable to optimize material usage and save space.
  4. Mount to structural support channels on top of guide rail system as applicable in hoistway overhead.
- B. Governor:
1. Tension type over-speed governor with remote manual reset.
  2. Mount to structural support channels as applicable in hoistway overhead.
- C. Buffers, Car and Counterweight: Compression spring type buffers to meet code.
- D. Hoistway Operating Devices:
1. Emergency Stop switch in the pit.
  2. Terminal stopping switches.
  3. Emergency stop switch on the machine.
- E. Positioning System: System consisting of proximity sensors and door zone vanes.
- F. F. Guide Rails and Attachments: Provide Tee-section steel rails with brackets and fasteners. Side counterweight arrangements shall have a dual purpose bracket that combines both counterweight guide rails, and one of the car guide rails to building fastening.
- G. Suspension System: Non circular Elastomeric coated suspension media with high tensile grade steel cords.
- H. Governor rope: Steel wire rope with 6 mm diameter.

#### **2.05 EQUIPMENT: HOISTWAY ENTRANCES**

- A. Hoistway Doors and Frames:
1. UL rated with required fire rating.
  2. Doors: Rigid flush panel construction with reinforcement ribs.
  3. Frames: Securely fasten at corners to form unit frame. Frames shall be bolted.
- B. Finish:
1. Exposed Areas of Corridor Frames: Painted Primer - All Floors
  2. Exposed Areas of Corridor Frames: Painted Primer - All Floors
  3. Exposed Areas of Corridor Frames:
    - a. 1st Floor: Painted Primer
    - b. 2nd Floor: Painted Primer
    - c. 3rd Floor: Painted Primer
    - d. Typical Floors: Painted Primer
  4. Doors: Painted Primer - All Floors
  5. Doors: Painted Primer - All Floors
  6. Doors:

- a. 1st Floor: Painted Primer
- b. 2nd Floor: Painted Primer
- c. 3rd Floor: Painted Primer.
- d. Typical Floor: Painted Primer
- 7. Sills: Aluminum - All Floors
- C. Entrance Markings and Jamb Plates: Provide standard entrance jamb tactile markings on both jambs, at all floors. Plate Mounting: Refer to manufacturer drawings.

## **2.06 EQUIPMENT: CAR COMPONENTS**

- A. Car Frame and Safety: Provide car frame with adequate bracing to support the platform and car enclosure. The safety shall be integral to the car frame and shall be flexible guide clamp type.
- B. Platform: Provide platform of steel construction with plywood subfloor and aluminum threshold.
- C. Car Guides: Provide sliding guide shoes mounted to top and bottom of both car and counterweight frame. Arrange each guide shoe assembly to maintain constant contact on the rail surfaces. Provide retainers in areas with Seismic design requirements.
- D. Provide central guiding system to reduce mechanical friction and energy consumption.
- E. Steel Cab:
  - 1. Fire rating: Provide Class B fire rating for cab, or Class A fire rating where required by local Code.
  - 2. Design cab to comply with LEED Indoor Environmental Quality requirements through use of Low-Emitting Materials on walls, ceiling and subflooring.
  - 3. Car wall finish: Wood-grain color plastic laminate finish selected from manufacturer's standard selections.
  - 4. Base and frieze: Aluminum.
  - 5. Car front finish: Brushed stainless steel.
  - 6. Car door finish: Brushed stainless steel.
  - 7. Ceiling: Canopy ceiling, finished in #4 Stainless Steel With Down Lit Led Lighting. Provide lighting consisting of four compact fluorescent energy saving lights located in two semi-oval lateral cutouts located on the center-sides of the cab ceiling, Lexan lens cover.
  - 8. Handrail: 1 3/8" Round And Curved Painted Aluminum. Locate on Rear & Side Walls.
  - 9. Flooring: Carpet Tile, By others. Not to exceed 3/8" finished depth.
  - 10. Ventilation: Provide one-speed fan in canopy.
  - 11. Emergency Car Lighting: Provide an emergency power unit employing a 12 volt sealed rechargeable battery and static circuits to illuminate the elevator car and provide current to the alarm bell in the event of building power failure.
  - 12. Emergency Siren: Provide siren mounted on top of the car that is activated when the Alarm button in the car operating panel is engaged.
  - 13. Emergency Exit Switch: Provide an electrical contact to open the safety circuit when the emergency car top exit is opened. When the exit door is opened, the top exit switch shall signal the control and the car will be unable to move.
  - 14. Emergency Exit Lock: Provide an emergency exit lock where required by local code.
  - 15. Emergency Exit Guard: Provide emergency exit guard on top of car when required for hoistway wall to platform clearance exceeds 12" or for multiple cars in hoistway.

## **2.07 DOOR OPERATOR AND REOPENING DEVICES**

- A. Door Operator: Provide a closed loop VVVF high performance door operator with frequency controlled drive for fast and reliable operation to open and close the car and hoistway doors simultaneously.
- B. In case of interruption or failure of electric power, the doors can be readily opened by hand from within the car, in accordance with applicable code. Provide emergency devices and keys for opening doors from the landing as required by local code.
- C. Doors shall open automatically when the car has arrived at or is leveling at the respective landings. Doors shall close after a predetermined time interval or immediately upon pressing of



a car button. Provide door open button in the car operating panel. Momentary pressing of this button shall reopen the doors and reset the time interval.

- D. Provide door hangers and tracks for each car and hoistway door. Contour tracks to match the hanger sheaves. Design hangers for power operation with provisions for vertical and lateral adjustment. Hanger sheaves shall have polyurethane tires and pre-lubricated sealed for life bearings.
- E. Electronic Door Safety Device: Equip car doors with concealed transmitter and receiver infrared beam devices to detect presence of object in process of passing through hoistway entrance and car doorway (light curtain device).
  - 1. Use multi-beam scanning without moving parts to detect obstructions in door opening.
  - 2. Detector Device: Prevent doors from closing, or if they have already started closing, cause doors to reopen and remain open while object is within detection zone.
  - 3. Horizontal Beams: Minimum of 33 infra red beams to fill doorway from ground level to a height of 6 feet.

## **2.08 EQUIPMENT: SIGNAL DEVICES AND FIXTURES**

- A. Car Operating Panel: Provide a car operating panel with all push buttons, key switches and message indicators for elevator operation.
  - 1. Full height car operating panel shall be surface-mounted on front return.
  - 2. Comply with handicap requirements.
  - 3. Push Buttons: Mechanical, illuminating using long-lasting LEDs for each floor served.
  - 4. Emergency Buttons: Provide in accordance with code. Emergency alarm button, door open and door close buttons.
- B. Features of the Car Operating Panel Shall Include:
  - 1. Audible chime to signal that the car is either stopping at or passing a floor served by the elevator.
  - 2. Raised markings and Braille provided to the left hand side of each push button.
  - 3. Car Lantern: Provide LED illuminated car lantern with direction arrows to comply with local code when hall lanterns are not provided.
  - 4. Door open and close push buttons.
  - 5. Firefighter's hat and Phase 2 Key-switch
  - 6. Inspection key-switch.
  - 7. Key-switch for optional Independent Service Operation
  - 8. Illuminated alarm button with raised marking.
  - 9. Elevator Data Plate marked with elevator capacity and car number.
  - 10. Help Button: Activation of help button will initiate two-way communication between car and a location inside the building, switching over to alternate location if call is unanswered, where personnel are available to take the appropriate action. Visual indicators are provided for call initiation and call acknowledgement.
- C. Hall Fixtures: Provide hall fixtures with necessary push buttons and key switches for elevator operation.
  - 1. Push buttons: Metallic tactile push buttons, up button and down button at intermediate floors, single button at each terminal floor.
- D. Height: Comply with handicap requirements.
  - 1. Illumination: Illuminating using long-lasting low power LEDs.
- E. Hall Lanterns and Position Indicators.
  - 1. LED illuminated direction arrows with audible and visible call acknowledgement.
- F. Hoistway access switches: Provide key-switch at top and/or bottom floor in entrance jamb as required by local code.
- G. Firefighter's Phase 1 Service: Key switch in brushed stainless steel cover plate.
- H. Fixture Cover Plates: For push buttons, hall lanterns and position indicators, resistant white back-printed glass, no screws required for mounting. Provide stainless steel cover plates for Firefighter's Phase I switch and hoistway access switches, with tamper resistant screws in

same finish.

- I. Mounting: Mount hall fixtures in entrance frames.

## **PART 3 – EXECUTION**

### **3.01 EXAMINATION**

- A. Examine hoistways, hoistway openings, and pits before starting elevator installation.
- B. Verify hoistway, pit, overhead, and openings are of correct size, within tolerances, and are ready for work of this section.
- C. Verify walls are plumb where openings occur and ready for entrance sill installation. Traditional sill angle or concrete sill support shall not be required.
- D. Verify hoistway is clear and plumb, with variations not to exceed -0 to +1 inch at any point. Verify projections greater than 4" must be beveled not less than 75 degrees from horizontal. No negative tolerance is permitted for minimum hoistway dimensions.
- E. Verify minimum 2-hour fire-resistance rating of hatch walls.
- F. Notify Architect in writing of dimensional discrepancies or other conditions detrimental to proper installation or performance of elevators.
- G. Do not proceed with elevator installation until unsatisfactory conditions have been corrected in a manner acceptable to manufacturer/installer.

### **3.02 INSTALLATION**

- A. Install elevators in accordance with manufacturer/installer's instructions and ANSI/ASME A17.1.
- B. Set entrances in vertical alignment with car openings, and aligned with plumb hoistway lines.
- C. Submit all documents for review to entities having jurisdiction.

### **3.03 FIELD QUALITY CONTROL**

- A. Perform tests of elevator as required by ANSI/ASME A17.1 and governing codes.

### **3.04 ADJUSTING**

- A. Adjust elevators for proper operation in accordance with manufacturer/installer's instructions.
- B. Adjust elevators for smooth acceleration and deceleration of car so not to cause passenger discomfort.
- C. Adjust doors to prevent opening of doors at landing on corridor side, unless car is at rest at that landing, or is in leveling zone and stopping at that landing.
- D. Adjust automatic floor leveling feature at each floor to within 1/4 inch of landing.
- E. Repair minor damages to finish in accordance with manufacturer/installer's instructions and as approved by Architect.
- F. Remove and replace damaged components that cannot be successfully repaired as determined by Architect.

### **3.05 CLEANING**

- A. Clean elevators promptly after installation in accordance with manufacturer/installer's instructions.
- B. Do not use harsh cleaning materials or methods that could damage finish.

### **3.06 PROTECTION**

- A. A. Protect installed elevators from damage during construction in accordance with the negotiated temporary use agreement between Owner and manufacturer's installer.

**END OF SECTION**

**SECTION 220516  
EXPANSION FITTINGS AND LOOPS FOR PLUMBING PIPING**

**PART 1 GENERAL**

**1.01 SECTION INCLUDES**

- A. Flexible pipe connectors.
- B. Expansion joints and compensators.
- C. Pipe loops, offsets, and swing joints.

**1.02 SUBMITTALS**

- A. Product Data:
  - 1. Flexible Pipe Connectors: Indicate maximum temperature and pressure rating, face-to-face length, live length, hose wall thickness, hose convolutions per foot (meter) and per assembly, fundamental frequency of assembly, braid structure, and total number of wires in braid.
  - 2. Expansion Joints: Indicate maximum temperature and pressure rating, and maximum expansion compensation.

**PART 2 PRODUCTS**

**2.01 REGULATORY REQUIREMENTS**

- A. Comply with UL (DIR) requirements.

**2.02 FLEXIBLE PIPE CONNECTORS - STEEL PIPING**

- A. Inner Hose: Stainless steel.
- B. Exterior Sleeve: Single braided, stainless steel.
- C. Pressure Rating: 125 psi up to 12 inch (862 kPa up to 300 mm, DN).
- D. Maximum Service Temperature: 450 degrees F (232 degrees C).
- E. End Connections: Threaded.
- F. Size: Use pipe sized units.
- G. Maximum offset: 3/4 inch (20 mm) on each side of installed center line.

**2.03 FLEXIBLE PIPE CONNECTORS - COPPER PIPING**

- A. Inner Hose: Bronze.
- B. Exterior Sleeve: Braided bronze.
- C. Pressure Rating: 125 psi up to 2 inch (862 kPa up to 50 mm, DN).
- D. Maximum Service Temperature: 450 degrees F (232 degrees C).
- E. End Connections: Flanged.
- F. Size: Use pipe sized units.
- G. Maximum offset: 3/4 inch (20 mm) on each side of installed center line.
- H. Application: Copper piping.

**2.04 EXPANSION JOINTS - STAINLESS STEEL BELLOWS TYPE**

- A. Pressure Rating: 125 psi and 400 degrees F (862 kPa and 204 degrees C).
- B. Maximum Compression: 1-3/4 inches (45 mm).
- C. Maximum Extension: 1/4 inch (6 mm).
- D. Joint Type: Externally pressurized with flanged ends.
- E. Size: Use pipe sized units.
- F. Application: Steel piping 4 inches (102 mm) and under.

## **2.05 EXPANSION JOINTS - EXTERNAL RING CONTROLLED STAINLESS STEEL BELLOWS TYPE**

- A. Pressure Rating: 125 psi and 400 degrees F (862 kPa and 204 degrees C).
- B. Maximum Compression: 15/16 inch (24 mm).
- C. Maximum Extension: 5/16 inch (8 mm).
- D. Maximum Offset: 1/8 inch (3 mm).
- E. End Connections: Flanged.
- F. Size: Use pipe sized units.
- G. Accessories: Internal flow liner.
- H. Application: Steel piping over 2 inches (50 mm).

## **2.06 EXPANSION JOINTS - SINGLE SPHERE, FLEXIBLE CONNECTOR**

- A. Body Construction: Nylon-reinforced rubber tube.
- B. End Connections: Carbon steel flanges.
- C. Cover and Tube Elastomer: EPDM and EPDM.
- D. Maximum Compression: 1/2 inch (13 mm).
- E. Maximum Elongation: 3/8 inch (10 mm).
- F. Maximum Offset: 3/8 inch (10 mm).
- G. Maximum Angular Movement: 15 degrees.
- H. Accessories: Control rods.
- I. Service Rating: Up to 35 psi at 220 degrees F (241.3 kPa at 104.4 degrees C).

## **2.07 EXPANSION JOINTS - TWO-PLY BRONZE BELLOWS TYPE**

- A. Construction: Bronze with anti-torque device, limit stops, internal guides.
- B. Pressure Rating: 125 psi and 400 degrees F (862 kPa and 204 degrees C).
- C. Maximum Compression: 1-3/4 inches (45 mm).
- D. Maximum Extension: 1/4 inch (6 mm).
- E. Joint: Soldered.
- F. Size: Use pipe sized units.
- G. Application: Copper piping.

## **2.08 EXPANSION JOINTS - COMPENSATORS**

- A. Type: Two-ply 304 stainless steel bellows with carbon steel shroud.
- B. Maximum Working Pressure: 200 psi (1378.9 kPa).
- C. Maximum Working Temperature: 400 degrees F (205 degrees C).
- D. Maximum Compression: 1/2 inch (12.7 mm).
- E. Maximum Extension: 5/32 inch (4.0 mm).
- F. End Connections: Female copper sweat.
- G. Application: Copper piping up to 3 inches (75 mm, DN) in size or steel piping up to 4 inches (100 mm, DN) in size.

## **2.09 EXPANSION JOINTS - STEEL WITH PACKED SLIDING SLEEVE**

- A. Working Pressure and Temperature: Class 150.
- B. End Connections: Flanged.
- C. Size: Use pipe sized units.
- D. Application: Steel piping 2 inches (50 mm) and over.

**2.10 EXPANSION JOINTS - COPPER WITH PACKED SLIDING SLEEVE**

- A. Working Pressure: 125 psi (862 kPa).
- B. Maximum Temperature: 250 degrees F (121 degrees C).
- C. End Connections: Flanged.
- D. Size: Use pipe sized units.
- E. Application: Copper or steel piping 2 inches (50 mm) and over.

**2.11 EXPANSION JOINTS AND LOOPS - HOSE AND BRAID**

- A. Provide flexible loops with two flexible sections of hose and braid, two 90 degree elbows, and 180 degree return with support brackets and plugged drain port for steam service.
- B. Maximum Allowable Motion: 2 inch (50.8 mm) in the x, y, and z planes with no thrust loads to the building structure.
- C. Maximum Working Pressure: 150 psi (1030 kPa) at 800 degrees F (426.7 degrees C).
- D. Construction: Class 150, schedule 40, stainless steel hose and braid assembly with carbon steel fittings, including elbows and flanged end connections sized to match pipe segment.
  - 1. Selected Product to Accommodate:
    - a. Compression and Expansion.
    - b. Angular Rotation: 15 degrees.
    - c. Force developed by 1.5 times specified maximum allowable operating pressure.
  - 2. Provide necessary accessories including, but not limited to, swivel joints.

**2.12 EXPANSION JOINTS - EXTERNALLY PRESSURIZED**

- A. Bellows Type: Two-ply, single bellows constructed of 304 stainless steel.
- B. Internal Liner: Carbon steel with internal and external guides.
- C. Specialty: Carbon steel anchor base, lifting lugs, and drain port with tapered plug.
- D. End Connections: Class 150, carbon steel, welded flange.
- E. Maximum Axial Compression: 4 inches (102 mm).
- F. Maximum Working Pressure: 150 psi (1030 kPa) at 700 degrees F (372 degrees C).
- G. Application: Steel piping 2 inches (50 mm) and over.

**2.13 ACCESSORIES**

- A. Stainless Steel Pipe: ASTM A269/A269M, seamless type, Grade TP304.
- B. -----
- C. Note to Specifier: The stainless steel material option above is an accessory not relating to the material of the other products below.
- D. -----
- E. Pipe Alignment Guides:
  - 1. Two piece welded steel with enamel paint, bolted, with spider to fit standard pipe, frame with four mounting holes, clearance for minimum 1 inch (25 mm) thick insulation, minimum 3 inches (75 mm) travel.
- F. Swivel Joints:
  - 1. Fabricated steel body, double ball bearing race, field lubricated, with rubber (Buna-N) o-ring seals.

**PART 3 EXECUTION**

**3.01 INSTALLATION**

- A. Install in accordance with manufacturer's instructions.
- B. Install flexible pipe connectors on pipes connected to vibration isolated equipment. Provide line size flexible connectors.

- C. Install flexible connectors at right angles to displacement. Install one end immediately adjacent to isolated equipment and anchor other end. Install in horizontal plane unless indicated otherwise.
- D. Anchor pipe to building structure where indicated. Provide pipe guides so movement is directed along axis of pipe only. Erect piping such that strain and weight is not on cast connections or apparatus.
- E. Provide support and equipment required to control expansion and contraction of piping. Provide loops, pipe offsets, and swing joints, or expansion joints where required.
- F. Substitute grooved piping for vibration isolated equipment instead of flexible connectors. Grooved piping need not be anchored.

**END OF SECTION**

**SECTION 220529  
HANGERS AND SUPPORTS FOR PLUMBING PIPING AND EQUIPMENT**

**PART 1 GENERAL**

**1.01 SECTION INCLUDES**

- A. Prefabricated trapeze-framed systems.
- B. Strut systems for pipe or equipment support.
- C. Beam clamps.
- D. Pipe hangers.
- E. Pipe rollers and roller supports.
- F. Pipe supports, guides, shields, and saddles.
- G. Nonpenetrating rooftop supports for low-slope roofs.
- H. Anchors and fasteners.

**1.02 ADMINISTRATIVE REQUIREMENTS**

- A. Coordination:
  - 1. Coordinate sizes and arrangement of supports and bases with the actual equipment and components to be installed.
  - 2. Coordinate the work with other trades to provide additional framing and materials required for installation.
  - 3. Coordinate compatibility of support and attachment components with mounting surfaces at the installed locations.
  - 4. Coordinate the arrangement of supports with ductwork, piping, equipment and other potential conflicts installed under other sections or by others.
  - 5. Notify Architect of any conflicts with or deviations from Contract Documents. Obtain direction before proceeding with work.
- B. Sequencing:
  - 1. Do not install products on or provide attachment to concrete surfaces until concrete has fully cured.

**1.03 SUBMITTALS**

- A. Product Data: Provide manufacturer's standard catalog pages and data sheets for metal channel (strut) framing systems, nonpenetrating rooftop supports, post-installed concrete and masonry anchors, and thermal insulated pipe supports.

**PART 2 PRODUCTS**

**2.01 GENERAL REQUIREMENTS**

- A. Provide required hardware to hang or support piping, equipment, or fixtures with related accessories as necessary to complete installation of plumbing work.
- B. Provide hardware products listed, classified, and labeled as suitable for intended purpose.
- C. Where support and attachment component types and sizes are not indicated, select in accordance with manufacturer's application criteria as required for the load to be supported. Include consideration for vibration, equipment operation, and shock loads where applicable.
- D. Do not use wire, chain, perforated pipe strap, or wood for permanent supports unless specifically indicated or permitted.
- E. Fire Resistance: Provide hardware rated for 60 minutes resistance unless specifically indicated by the authority having jurisdiction.
- F. Materials for Metal Fabricated Supports:
  - 1. Zinc-Plated Steel: Electroplated in accordance with ASTM B633 unless stated otherwise.
  - 2. Galvanized Steel: Hot-dip galvanized in accordance with ASTM A123/A123M or ASTM A153/A153M unless stated otherwise.

- G. Corrosion Resistance: Use corrosion-resistant metal-based materials fully compatible with exposed piping materials and suitable for the environment where installed.
  - 1. Indoor Dry Locations: Use zinc-plated steel or approved equivalent unless otherwise indicated.
  - 2. Outdoor, Damp, or Wet-Indoor Locations: Use galvanized steel, stainless steel, or approved equivalent unless otherwise indicated.

## **2.02 PREFABRICATED TRAPEZE-FRAMED SYSTEMS**

- A. Prefabricated Trapeze-Framed Metal Strut Systems:
  - 1. MFMA-4 compliant, pre-fabricated, MSS SP-58 Type 59 continuous-slot metal strut channel with associated tracks, fittings, and related accessories.
  - 2. MFMA-4 compliant, prefabricated, side-loading continuous-slot metal strut channel bracket with associated tracks, fittings, and related accessories.
  - 3. Strut Channel or Bracket Material:
    - a. Indoor Dry Locations: Use zinc-plated steel or galvanized steel.
    - b. Outdoor and Damp or Wet Indoor Locations: Use galvanized steel.
  - 4. Minimum Channel Thickness: Steel sheet, 12 gauge, 0.1046 inch (2.66 mm).
  - 5. Minimum Channel Dimensions: 1-5/8 inch (41 mm) width by 13/16 inch (21 mm) height.
  - 6. Accessories: Provide bracket covers, cable basket clips, cable tray clips, clamps, conduit clamps, fire-retarding brackets, j-hooks, protectors, and vibration dampeners.

## **2.03 STRUT SYSTEMS FOR PIPE OR EQUIPMENT SUPPORT**

- A. Strut Channels:
  - 1. ASTM A653/A653M galvanized steel bracket with clamps for surface mounting of piping or plumbing equipment support.
  - 2. Channel or Bracket Kits: Include rods, brackets, end-fixed fittings, covers, clips, and other related hardware required to complete sectional trapeze section for piping or other support.
- B. Hanger Rods:
  - 1. Threaded zinc-plated steel unless otherwise indicated.
  - 2. Minimum Size, Unless Otherwise Indicated or Required:
    - a. Equipment Supports: 1/2 inch (13 mm, DN) diameter.
    - b. Piping up to 1 inch (25 mm, DN): 1/4 inch (6 mm, DN) diameter.
    - c. Piping larger than 1 inch (25 mm, DN): 3/8 inch (10 mm, DN) diameter.
    - d. Trapeze Support for Multiple Pipes: 3/8 inch (10 mm) in length.
- C. Channel Nuts:
  - 1. Provide carbon steel channel nut with epoxy copper or zinc finish and long, regular, or short spring as indicated on drawings.
- D. Cable Hanging System Kits:
  - 1. Provide cable-wire in bulk or pre-cut lengths with respective cable hangers as required to hold minimum weight of 120 lb (54.4 kg).
  - 2. Accessories: Provide brackets, clip or c-clip hangers, covers, and y-hook hangers.

## **2.04 BEAM CLAMPS**

- A. MSS SP-58 types 19 through 23, 25 or 27 through 30 based on required load.
- B. C-Clamp: MSS SP-58 type 23, malleable iron and steel with plain, stainless steel, and zinc finish.
- C. Small or Junior Beam Clamp: MSS SP-58 type 19, malleable iron with plain finish. For inverted usage provide manufacturer listed size(s).
- D. Wide Mouth Beam Clamp: MSS SP-58 type 19, malleable iron with plain finish.
- E. Centerload Beam Clamp with Extension Piece: MSS SP-58 type 30, malleable iron with plain finish.
- F. FM (AG) and UL (DIR) Approved Beam Clamp: MSS SP-58 type 19, plain finish.



- G. Provide clamps with hardened steel cup-point set screws and lock-nuts for anchoring in place.
- H. Material: ASTM A395/A395M ductile iron, ASTM A36/A36M carbon steel, ASTM A47/A47M malleable iron, ASTM A181/A181M forged steel, or ASTM A283/A283M steel.

## 2.05 PIPE HANGERS

- A. Band Hangers, Adjustable:
  - 1. MSS SP-58 type 7 or 9, zinc-plated ASTM A1011/A1011M steel or ASTM A653/A653M carbon steel.
- B. J-Hangers, Adjustable:
  - 1. MSS SP-58 type 5, zinc-plated ASTM A1011/A1011M steel or ASTM A653/A653M carbon steel.
  - 2. Felt-Lined: Provide for uninsulated pipe to reduce noise and prevent static issues.
- C. Swivel Ring Hangers, Adjustable:
  - 1. MSS SP-58 type 10, epoxy-painted, zinc-colored.
  - 2. Material: ASTM A395/A395M ductile iron, ASTM A36/A36M carbon steel, ASTM A47/A47M malleable iron, ASTM A181/A181M forged steel, or ASTM A283/A283M steel.
  - 3. FM (AG) and UL (DIR) listed for specific pipe size runs and loads.
  - 4. Felt-Lined: Provide for uninsulated pipe to reduce noise and prevent static issues.
- D. Clevis Hangers, Adjustable:
  - 1. Copper Tube: MSS SP-58 type 1, epoxy-plated copper.
  - 2. Felt-Lined: MSS SP-58 type 1, zinc-plated, silicone-free carbon steel.
  - 3. Light-Duty: MSS SP-58 type 1, zinc-colored, epoxy plated.
  - 4. Standard-Duty: MSS SP-58 type 1, zinc-colored, epoxy plated.
  - 5. UL (DIR) listed: Pipe sizes 2-1/2 to 8 inch (65 to 200 mm, DN).
  - 6. FM (AG) listed: Pipe sizes 2-1/2 to 8 inch (65 to 200 mm, DN).
- E. Nonmetallic Pipe Hangers:
  - 1. CPVC fabricated, snap-action hanger for pendant or sidewall applications.

## 2.06 PIPE CLAMPS

- A. Riser Clamps:
  - 1. For insulated pipe runs, provide two bolt-type clamps designed for installation under insulation.
  - 2. MSS SP-58 type 1 or 8, carbon steel or steel with epoxy plated, plain, stainless steel, or zinc plated finish.
  - 3. Medium Split Horizontal Pipe Clamp: MSS SP-58 type 4, carbon steel or stainless steel with epoxy plated, plain, stainless steel, or zinc plated finish.
  - 4. Copper Tube Pipe Clamp: MSS SP-58 type 8, epoxy plated copper.
  - 5. UL (DIR) listed: Pipe sizes 1/2 to 8 inch (15 to 200 mm, DN).
- B. Extension Split Pipe Clamp:
  - 1. MSS SP-58 type 12, hinged split ring and yoke roller hanger with epoxy copper or plain finish.
  - 2. Material: ASTM A47/A47M malleable iron or ASTM A36/A36M carbon steel.
  - 3. Provide hanger rod and nuts of the same type and material for a given pipe run.
  - 4. Provide coated or plated hangers to isolate steel hangers from dissimilar metal tube or pipe.
- C. Offset Pipe Clamps: Double-leg design two-piece pipe clamp.
- D. Strut Clamps:
  - 1. Pipe Clamp: Two-piece rigid, universal, or outer diameter type, carbon steel with epoxy copper or zinc finish.
  - 2. Cushioned Pipe or Tubing Strut Clamp: Provide strut clamp with thermoplastic elastomer cushion having dielectric strength of 670 V/mil (26,398,000 V/m).
  - 3. Service Temperature Range: Minus 65 to 275 degrees F (Minus 53.8 to 135 degrees C).

- E. Insulation Coupling:
  - 1. Two bolt-type clamps designed for installation under insulation.
  - 2. Material: Carbon steel with epoxy copper or zinc finish.

## **2.07 PIPE ROLLERS AND ROLLER SUPPORTS**

- A. MSS SP-58 type 43 based on required load, nonconductive and corrosion resistant.
- B. Steel Yoke Type: MSS SP-58 type 44, vertically adjustable, nonconductive, and corrosion resistant.
- C. Material: Zinc plated ASTM A36/A36M carbon steel or ASTM A47/A47M malleable iron.

## **2.08 PIPE SUPPORTS, GUIDES, SHIELDS, AND SADDLES**

- A. Dielectric Barriers: Provide between metallic supports and metallic piping and associated items of dissimilar type; acceptable dielectric barriers include rubber or plastic sheets or coatings attached securely to pipe or item.
- B. Stanchions:
  - 1. Material: Malleable iron, ASTM A47/A47M; or carbon steel, ASTM A36/A36M.
  - 2. Provide coated or plated saddles to isolate steel hangers from dissimilar metal tube or pipe.
  - 3. For pipe runs, use stanchions of same type and material where vertical adjustment is required for stationary pipe.
- C. U-Bolts:
  - 1. MSS SP-58 type 24, carbon steel u-bolt for pipe support or anchoring.
- D. Intermediate Anchors and Pipe Alignment Guides:
  - 1. Pipe Sizes 6 inch (150 mm, DN) and Smaller: Minimum clearance of 0.16 inch (4 mm).
  - 2. Pipe Size 8 inch (200 mm, DN): 0.625 inch (16 mm) U-bolt with double nuts providing minimum clearance of 0.28 inch (7 mm).
  - 3. Pipe Size 10 inch (250 mm, DN): 0.75 inch (19 mm) U-bolt.
  - 4. Pipe Sizes 12 to 16 inch (300 to 400 mm, DN): 0.875 inch (24 mm) U-bolt.
  - 5. Pipe Sizes 18 to 30 inches (450 to 750 mm, DN): 1 inch (25 mm) U-bolt.
  - 6. Use pipe clamps with oversize pipe sleeve that provides clearance around pipe.
- E. Pipe Alignment Guides, Galvanized steel:
  - 1. Pipe Sizes 8 inch (200 mm, DN) and Smaller: Spider or sleeve type.
  - 2. Pipe Sizes 10 inch (250 mm, DN) and Larger: Roller type.
  - 3. Pipe Sizes 18 to 30 inch (450 to 750 mm, DN): 1 inch (25 mm) U-bolt.
- F. Pipe Shields for Insulated Piping:
  - 1. MSS SP-58 type 40, ASTM A1011/A1011M steel or ASTM A653/A653M carbon steel.
  - 2. General Construction and Requirements:
    - a. Surface Burning Characteristics: Comply with ASTM E84 or UL 723.
    - b. Shields Material: UV-resistant polypropylene with glass fill.
    - c. Maximum Insulated Pipe Outer Diameter: 12-5/8 inch (321 mm).
    - d. Service Temperature: Minus 40 to 178 degrees F (Minus 40 to 81 degrees C).
    - e. Pipe shields to be provided at hanger, support, and guide locations on pipe requiring insulation or additional support.
- G. Pipe Supports:
  - 1. Material: ASTM A395/A395M ductile iron, ASTM A36/A36M carbon steel, ASTM A47/A47M malleable iron, ASTM A181/A181M forged steel, or ASTM A283/A283M steel.
  - 2. Liquid Temperatures Up to 122 degrees F (50 degrees C):
    - a. Overhead Support: MSS SP-58 types 1, 3 through 12 clamps.
    - b. Support From Below: MSS SP-58 types 35 through 38.
  - 3. Operating Temperatures from 122 to 446 degrees F (50 to 230 degrees C):
    - a. Overhead Support: MSS SP-58 type 1 or 3 through 12 clamps with appropriate saddle of MSS SP-58 type 40 for insulated pipe.

- b. Roller Chair: MSS SP-58 types 41 or 43 through 46 roller chair support with appropriate saddle of MSS SP-58 type 39 for insulated pipe.
  - c. Sliding Support: MSS SP-58 types 35 through 38.
- H. Pipe Supports, Thermal Insulated:
- 1. General Requirements:
    - a. Insulated pipe supports to be provided at hanger, support, and guide locations on pipe requiring insulation or additional support.
    - b. Pipe insulation protection shields to be provided at the hanger points and guide locations on pipes requiring insulation as indicated on drawings.
    - c. Surface Burning Characteristics: Flame spread index/smoke developed index of 5/30, maximum, when tested in accordance with ASTM E84 or UL 723.
    - d. Provide pipe supports for 1/2 to 30 inch (15 to 750 mm, DN) iron pipes.
    - e. Insulation inserts to consist of rigid phenolic foam insulation surrounded by 360 degree, PVC jacketing.
  - 2. PVC Jacket:
    - a. Pipe insulation protection shields to be provided with ball bearing hinge and locking seam.
    - b. Minimum Service Temperature: Minus 40 degrees F (Minus 40 degrees C).
    - c. Maximum Service Temperature: 180 degrees F (82 degrees C).
    - d. Moisture Vapor Transmission: 0.0071 perm inch (0.0092 ng/Pa s m), when tested in accordance with ASTM E96/E96M.
    - e. Minimum Thickness: 60 mil, 0.06 inch (1.524 mm).
    - f. Connections: Brush-on welding adhesive.
- I. Thermal Insulated, Surface-Mounted Pipe Supports:
- 1. Material: Carbon steel with epoxy copper or zinc finish.
  - 2. Weather and UV light resistant foam, plastic, or rubber material with built-in strut.  
Maximum Load: 50 lb (22.7 kg) for single pipe or multiple landed on top strut.

## 2.09 NONPENETRATING ROOFTOP SUPPORTS FOR LOW-SLOPE ROOFS

- A. Provide steel pedestals with thermoplastic or rubber base that rest on top of roofing membrane, not requiring any attachment to the roof structure and not penetrating the roofing assembly, with support fixtures as specified.
- B. Base Sizes: As required to distribute load sufficiently to prevent indentation of roofing assembly.
- C. Attachment/Support Fixtures: As recommended by manufacturer, same type as indicated for equivalent indoor hangers and supports.
- D. Mounting Height: Provide minimum clearance of 6 inches (150 mm) under supported component to top of roofing.

## 2.10 ANCHORS AND FASTENERS

- A. Unless otherwise indicated and where not otherwise restricted, use the anchor and fastener types indicated for the specified applications.
- B. Concrete: Use preset concrete inserts, expansion anchors, or screw anchors.
- C. Solid or Grout-Filled Masonry: Use expansion anchors or screw anchors.
- D. Hollow Masonry: Use toggle bolts.
- E. Hollow Stud Walls: Use toggle bolts.
- F. Steel: Use beam ceiling clamps, beam clamps, machine bolts, or welded threaded studs.
- G. Beam Ceiling Flanges: ASTM A47/A47M Grade 32510, malleable iron or stainless steel with copper, plain, stainless steel, or zinc finish.
- H. Sheet Metal: Use sheet metal screws.
- I. Wood: Use wood screws.

- J. Plastic and lead anchors are not permitted.
- K. Powder-actuated fasteners are not permitted.
- L. Hammer-driven anchors and fasteners are not permitted.
- M. Post-Installed Concrete and Masonry Anchors: Evaluated and recognized by ICC Evaluation Service, LLC (ICC-ES) for compliance with applicable building code.
- N. Preset Concrete Inserts: Continuous metal strut channel and spot inserts specifically designed to be cast in concrete ceilings, walls, and floors.
  - 1. Channel Material: Use galvanized steel.
  - 2. Minimum Channel Thickness: Steel sheet, 12 gauge, 0.1046 inch (2.66 mm) minimum base metal thickness.
  - 3. Manufacturer: Same as manufacturer of metal strut channel framing system.

## **PART 3 EXECUTION**

### **3.01 EXAMINATION**

- A. Verify that mounting surfaces are ready to receive support and attachment components.
- B. Verify that conditions are satisfactory for installation prior to starting work.

### **3.02 INSTALLATION**

- A. Install products in accordance with manufacturer's instructions.
- B. Install anchors and fasteners in accordance with ICC Evaluation Services, LLC (ICC-ES) evaluation report conditions of use where applicable.
- C. Provide independent support from building structure. Do not provide support from piping, ductwork, conduit, or other systems.
- D. Unless specifically indicated or approved by Architect, do not provide support from suspended ceiling support system or ceiling grid.
- E. Unless specifically indicated or approved by Architect, do not provide support from roof deck.
- F. Do not penetrate or otherwise notch or cut structural members without approval of Structural Engineer.
- G. Provide thermal insulated pipe supports complete with hangers and accessories. Install thermal insulated pipe supports during the installation of the piping system.
- H. Equipment Support and Attachment:
  - 1. Use metal fabricated supports or supports assembled from metal channel (strut) to support equipment as required.
  - 2. Use metal channel (strut) secured to studs to support equipment surface-mounted on hollow stud walls when wall strength is not sufficient to resist pull-out.
  - 3. Use metal channel (strut) to support surface-mounted equipment in wet or damp locations to provide space between equipment and mounting surface.
  - 4. Securely fasten floor-mounted equipment. Do not install equipment such that it relies on its own weight for support.
- I. Preset Concrete Inserts: Use manufacturer-provided closure strips to inhibit concrete seepage during concrete pour.
- J. Secure fasteners according to manufacturer's recommended torque settings.
- K. Remove temporary supports.

### **3.03 FIELD QUALITY CONTROL**

- A. Inspect support and attachment components for damage and defects.
- B. Repair cuts and abrasions in galvanized finishes using zinc-rich paint recommended by manufacturer. Replace components that exhibit signs of corrosion.
- C. Correct deficiencies and replace damaged or defective support and attachment components.

**END OF SECTION**

**SECTION 220716  
PLUMBING EQUIPMENT INSULATION**

**PART 1 GENERAL**

**1.01 SECTION INCLUDES**

- A. Flexible elastomeric cellular insulation.
- B. Flexible glass fiber insulation.
- C. Rigid glass fiber insulation.
- D. Weather barrier coatings.
- E. Jacketing and accessories.

**1.02 SUBMITTALS**

- A. Product Data: Provide product description, thermal characteristics, list of materials and thickness for equipment scheduled.

**1.03 DELIVERY, STORAGE, AND HANDLING**

- A. Accept materials on site in original factory packaging, labeled with manufacturer's identification, including product density and thickness.
- B. Protect insulation from weather and construction traffic, dirt, water, chemical, and mechanical damage, by storing in original wrapping.

**1.04 FIELD CONDITIONS**

- A. Maintain ambient temperatures and conditions required by manufacturers of adhesives, mastics, and insulation cements.
- B. Maintain temperature during and after installation for minimum period of 24 hours.

**PART 2 PRODUCTS**

**2.01 REGULATORY REQUIREMENTS**

- A. Surface Burning Characteristics: Flame spread index/Smoke developed index of 25/50, maximum, when tested in accordance with ASTM E84 or UL 723.

**2.02 FLEXIBLE GLASS FIBER INSULATION**

- A. Insulation: ASTM C553; flexible, noncombustible.
  - 1. K (Ksi) Value: 0.36 at 75 degrees F (0.052 at 24 degrees C), when tested in accordance with ASTM C177 or ASTM C518.
  - 2. Maximum Service Temperature: 450 degrees F (232 degrees C).
  - 3. Maximum Water Vapor Absorption: 5.0 percent by weight.
- B. Vapor Barrier Jacket: Kraft paper reinforced with glass fiber yarn and bonded to aluminized film.
  - 1. Moisture Vapor Permeability: 0.02 perm inch (0.029 ng/(Pa s m)), when tested in accordance with ASTM E96/E96M.
  - 2. Secure with self-sealing longitudinal laps and butt strips.
  - 3. Secure with outward clinch expanding staples and vapor barrier mastic.
- C. Tie Wire: 0.048 inch (1.22 mm) stainless steel with twisted ends on maximum 12 inch (300 mm) centers.
- D. Vapor Barrier Lap Adhesive: Compatible with insulation.
- E. Insulating Cement/Mastic: ASTM C195; hydraulic setting on mineral wool.

**2.03 RIGID GLASS FIBER INSULATION**

- A. Insulation: ASTM C612 or ASTM C592; rigid, noncombustible.
  - 1. K (Ksi) Value: 0.25 at 75 degrees F (0.036 at 24 degrees C), when tested in accordance with ASTM C177 or ASTM C518.
  - 2. Maximum Service Temperature: 850 degrees F (454 degrees C).

3. Maximum Water Vapor Absorption: 5.0 percent by weight.
  4. Maximum Density: 8.0 pcf (128 kg/cu m).
- B. Vapor Barrier Jacket:
1. Kraft paper reinforced with glass fiber yarn and bonded to aluminized film.
  2. Moisture Vapor Permeability: 0.02 perm inch (0.029 ng/(Pa s m)), when tested in accordance with ASTM E96/E96M.
  3. Secure with self-sealing longitudinal laps and butt strips.
  4. Secure with outward clinch expanding staples and vapor barrier mastic.
- C. Facing: 1 inch (25 mm) galvanized steel hexagonal wire mesh stitched on one face of insulation.
- D. Vapor Barrier Lap Adhesive: Compatible with insulation.
- E. Insulating Cement/Mastic: ASTM C195; hydraulic setting on mineral wool.

#### **2.04 FLEXIBLE ELASTOMERIC CELLULAR INSULATION**

- A. Insulation: Preformed flexible elastomeric cellular rubber insulation complying with ASTM C534/C534M Grade 1, in sheet form.
1. Minimum Service Temperature: Minus 40 degrees F (Minus 40 degrees C).
  2. Maximum Service Temperature: 220 degrees F (104 degrees C).
  3. Connection: Waterproof vapor barrier adhesive.
- B. Elastomeric Foam Adhesive: Air dried, contact adhesive, compatible with insulation.

#### **2.05 WEATHER BARRIER COATINGS**

- A. Weather-Resistive Barrier Coating: Fire-resistive, UV resistant, water-based mastic for use over closed cell polyethylene and polyurethane foam insulation; applied with glass fiber or synthetic reinforcing mesh.
1. Surface Burning Characteristics: Flame spread index of 25 or less, smoke developed index of 450 or less, Class A, when tested in accordance with ASTM E84.
  2. Water Vapor Permeance: Greater than 1.0 perm (57 ng/(Pa s m)) in accordance with ASTM E96/E96M.
  3. Resistance to Fungal Growth: No growth when tested in accordance with ASTM D5590.
  4. Color: White.

#### **2.06 JACKETING AND ACCESSORIES**

- A. PVC Plastic:
1. Jacket: Sheet material, off-white color.
    - a. Minimum Service Temperature: Minus 40 degrees F (Minus 40 degrees C).
    - b. Maximum Service Temperature: 150 degrees F (66 degrees C).
    - c. Moisture Vapor Permeability: 0.02 perm inch (0.029 ng/(Pa s m)), when tested in accordance with ASTM E96/E96M.
    - d. Thickness: 10 mil, 0.010 inch (0.25 mm).
    - e. Connections: Brush on welding adhesive.
  2. Covering Adhesive Mastic: Compatible with insulation.
- B. Canvas Jacket: UL listed 6 oz/sq yd (220 g/sq m) plain weave cotton fabric treated with dilute fire-retardant lagging adhesive.
1. Lagging Adhesive: Compatible with insulation.
- C. Aluminum Jacket:
1. Comply with ASTM B209/B209M, Temper H14, minimum thickness of 0.016 inch (0.41 mm) with factory-applied polyethylene and kraft paper moisture barrier on the inside surface.
  2. Thickness: 0.016 inch (0.40 mm) sheet.
  3. Finish: Smooth.
  4. Joining: Longitudinal slip joints and 2 inch (50 mm) laps.
  5. Fittings: 0.016 inch (0.40 mm) thick die-shaped fitting covers with factory-attached protective liner.

6. Metal Jacket Bands: 3/8 inch (10 mm) wide; 0.015 inch (0.38 mm) thick aluminum.
- D. Reinforced Tape:
1. FSK tape suitable for sealing seams between insulation, insulated pipe bends, and fittings resulting in a tight, smooth surface without wrinkles.
  2. Comply with UL 723 or ASTM E84.
  3. Moisture Vapor Permeability: 0.00 perm inch (0.00 ng/(Pa s m)), when tested in accordance with ASTM E96/E96M.
  4. Finish: Match insulation.

## **PART 3 EXECUTION**

### **3.01 EXAMINATION**

- A. Verify that equipment has been tested before applying insulation materials.
- B. Verify that surfaces are clean and dry, with foreign material removed.

### **3.02 INSTALLATION**

- A. Install in accordance with manufacturer's instructions.
- B. Factory Insulated Equipment: Do not insulate.
- C. Exposed Equipment: Locate insulation and cover seams in least visible locations.
- D. Apply insulation close to equipment by grooving, scoring, and beveling insulation. Fasten insulation to equipment with studs, pins, clips, adhesive, wires, or bands.
- E. Fill joints, cracks, seams, and depressions with bedding compound to form smooth surface. On cold equipment, use vapor barrier cement.
- F. Insulated equipment containing fluids below ambient temperature: Insulate entire system.
- G. For fiberglass insulated equipment containing fluids below ambient temperature, provide vapor barrier jackets, factory-applied or field-applied, and finish with glass cloth and vapor barrier adhesive.
- H. For hot equipment containing fluids 140 degrees F (60 degrees C) or less, do not insulate flanges and unions, but bevel and seal ends of insulation.
- I. For hot equipment containing fluids over 140 degrees F (60 degrees C), insulate flanges and unions with removable sections and jackets.
- J. Fiberglass insulated equipment containing fluids above ambient temperature: Provide standard jackets, with or without vapor barrier, factory-applied or field-applied. Finish with glass cloth and adhesive.
- K. Inserts and Shields:
  1. Application: Equipment 1-1/2 inches (40 mm) diameter or larger.
  2. Shields: Galvanized steel between hangers and inserts.
  3. Insert location: Between support shield and equipment and under the finish jacket.
  4. Insert configuration: Minimum 6 inches (150 mm) long, of same thickness and contour as adjoining insulation; may be factory fabricated.
  5. Insert material: Hydrous calcium silicate insulation or other heavy density insulating material suitable for the planned temperature range.
- L. Finish insulation at supports, protrusions, and interruptions.
- M. Equipment in Mechanical Equipment Rooms or Finished Spaces: Finish with PVC jacket and fitting covers.
- N. Exterior Applications:
  1. Provide vapor barrier jacket or finish with glass mesh reinforced vapor barrier cement.
  2. Cover with aluminum.
- O. Cover glass fiber insulation with metal mesh and finish with heavy coat of insulating cement.
- P. Nameplates and ASME Stamps: Bevel and seal insulation around; do not insulate over.

- Q. Equipment Requiring Access for Maintenance, Repair, or Cleaning: Install insulation so it can be easily removed and replaced without damage.

**END OF SECTION**



**SECTION 220719  
PLUMBING PIPING INSULATION**

**PART 1 GENERAL**

**1.01 SECTION INCLUDES**

- A. Flexible elastomeric cellular insulation.
- B. Glass fiber insulation.
- C. Weather barrier coatings.
- D. Jacketing and accessories.

**1.02 SUBMITTALS**

- A. Product Data: Provide product description, thermal characteristics, list of materials and thickness for each service, and locations.

**1.03 DELIVERY, STORAGE, AND HANDLING**

- A. Accept materials on site, labeled with manufacturer's identification, product density, and thickness.

**1.04 FIELD CONDITIONS**

- A. Maintain ambient conditions required by manufacturers of each product.
- B. Maintain temperature before, during, and after installation for minimum of 24 hours.

**PART 2 PRODUCTS**

**2.01 REGULATORY REQUIREMENTS**

- A. Surface Burning Characteristics: Flame spread index/Smoke developed index of 25/50, maximum, when tested in accordance with ASTM E84 or UL 723.

**2.02 GLASS FIBER INSULATION**

- A. Insulation: ASTM C547 and ASTM C795; rigid molded, noncombustible.
  - 1. K (Ksi) Value: ASTM C177, 0.24 at 75 degrees F (0.035 at 24 degrees C).
  - 2. Maximum Service Temperature: 850 degrees F (454 degrees C).
  - 3. Maximum Moisture Absorption: 0.2 percent by volume.
- B. Vapor Barrier Jacket: White Kraft paper with glass fiber yarn, bonded to aluminized film; moisture vapor transmission when tested in accordance with ASTM E96/E96M of 0.02 perm (0.029 ng/(Pa s m)).
- C. Tie Wire: 0.048 inch (1.22 mm) stainless steel with twisted ends on maximum 12 inch (300 mm) centers.
- D. Vapor Barrier Lap Adhesive: Compatible with insulation.
- E. Insulating Cement/Mastic: ASTM C195; hydraulic setting on mineral wool.
- F. Fibrous Glass Fabric:
  - 1. Cloth: Untreated; 9 oz/sq yd (305 g/sq m) weight.
  - 2. Blanket: 1.0 pcf (16 kg/cu m) density.
  - 3. Weave: 5 by 5.
- G. Indoor Vapor Barrier Finish:
  - 1. Cloth: Untreated; 9 oz/sq yd (305 g/sq m) weight.
  - 2. Vinyl emulsion type acrylic, compatible with insulation, white color.
- H. Outdoor Vapor Barrier Mastic: Vinyl emulsion type acrylic or mastic, compatible with insulation, black color.
- I. Outdoor Breather Mastic: Vinyl emulsion type acrylic or mastic, compatible with insulation, black color.
- J. Insulating Cement: ASTM C449.

## 2.03 FLEXIBLE ELASTOMERIC CELLULAR INSULATION

- A. Insulation: Preformed flexible elastomeric cellular rubber insulation complying with ASTM C534/C534M Grade 1; use molded tubular material wherever possible.
  - 1. Minimum Service Temperature: Minus 40 degrees F (Minus 40 degrees C).
  - 2. Maximum Service Temperature: 220 degrees F (104 degrees C).
  - 3. Connection: Waterproof vapor barrier adhesive.
- B. Elastomeric Foam Adhesive: Air dried, contact adhesive, compatible with insulation.
- C. Weather Barrier: Air dried, contact adhesive, compatible with insulation and ASTM E84 compliant.

## 2.04 WEATHER BARRIER COATINGS

- A. Weather-Resistive Barrier Coating: Fire-resistive, UV resistant, water-based mastic for use over closed cell polyethylene and polyurethane foam insulation; applied with glass fiber or synthetic reinforcing mesh.
  - 1. Surface Burning Characteristics: Flame spread index of 25 or less, smoke developed index of 450 or less, Class A, when tested in accordance with ASTM E84.
  - 2. Water Vapor Permeance: Greater than 1.0 perm (57 ng/(Pa s m)) in accordance with ASTM E96/E96M.
  - 3. Resistance to Fungal Growth: No growth when tested in accordance with ASTM D5590.
  - 4. Color: White.

## 2.05 JACKETING AND ACCESSORIES

- A. PVC Plastic Jacket:
  - 1. Jacket: One piece molded type fitting covers and sheet material, off-white color.
    - a. Minimum Service Temperature: 0 degrees F (Minus 18 degrees C).
    - b. Maximum Service Temperature: 150 degrees F (66 degrees C).
    - c. Moisture Vapor Permeability: 0.002 perm inch (0.0029 ng/(Pa s m)), maximum, when tested in accordance with ASTM E96/E96M.
    - d. Thickness: 10 mil, 0.010 inch (0.25 mm).
    - e. Connections: Brush on welding adhesive.
  - 2. Covering Adhesive Mastic: Compatible with insulation.
- B. Aluminum Jacket:
  - 1. Comply with ASTM B209/B209M, Temper H14, minimum thickness of 0.016 inch (0.41 mm) with factory-applied polyethylene and kraft paper moisture barrier on the inside surface.
  - 2. Thickness: 0.016 inch (0.40 mm) sheet.
  - 3. Finish: Smooth.
  - 4. Joining: Longitudinal slip joints and 2 inch (50 mm) laps.
  - 5. Fittings: 0.016 inch (0.40 mm) thick die-shaped fitting covers with factory-attached protective liner.
  - 6. Metal Jacket Bands: 3/8 inch (10 mm) wide; 0.015 inch (0.38 mm) thick aluminum.
- C. Reinforced Tape:
  - 1. FSK tape suitable for sealing seams between insulation, insulated pipe bends, and fittings resulting in a tight, smooth surface without wrinkles.
  - 2. Comply with UL 723 or ASTM E84.
  - 3. Moisture Vapor Permeability: 0.00 perm inch (0.00 ng/(Pa s m)), when tested in accordance with ASTM E96/E96M.
  - 4. Finish: Match insulation.

## PART 3 EXECUTION

### 3.01 EXAMINATION

- A. Verify that piping has been tested before applying insulation materials.
- B. Verify that surfaces are clean and dry, with foreign material removed.

### 3.02 INSTALLATION

- A. Install in accordance with manufacturer's instructions.
- B. Exposed Piping: Locate insulation and cover seams in least visible locations.
- C. Insulated pipes conveying fluids below ambient temperature: Insulate entire system including fittings, valves, unions, flanges, strainers, flexible connections, pump bodies, and expansion joints.
- D. Glass fiber insulated pipes conveying fluids below ambient temperature:
  - 1. Provide vapor barrier jackets, factory-applied or field-applied. Secure with self-sealing longitudinal laps and butt strips with pressure-sensitive adhesive. Secure with outward clinch expanding staples and vapor barrier mastic.
  - 2. Insulate fittings, joints, and valves with molded insulation of like material and thickness as adjacent pipe. Finish with glass cloth and vapor barrier adhesive or PVC fitting covers.
- E. For hot piping conveying fluids 140 degrees F (60 degrees C) or less, do not insulate flanges and unions at equipment, but bevel and seal ends of insulation.
- F. For hot piping conveying fluids over 140 degrees F (60 degrees C), insulate flanges and unions at equipment.
- G. Glass fiber insulated pipes conveying fluids above ambient temperature:
  - 1. Provide standard jackets, with or without vapor barrier, factory-applied or field-applied. Secure with self-sealing longitudinal laps and butt strips with pressure-sensitive adhesive. Secure with outward clinch expanding staples.
  - 2. Insulate fittings, joints, and valves with insulation of like material and thickness as adjoining pipe. Finish with glass cloth and adhesive or PVC fitting covers.
- H. Inserts and Shields:
  - 1. Application: Piping 1-1/2 inches (40 mm) diameter or larger.
  - 2. Shields: Galvanized steel between pipe hangers or pipe hanger rolls and inserts.
  - 3. Insert Location: Between support shield and piping and under the finish jacket.
  - 4. Insert Configuration: Minimum 6 inches (150 mm) long, of same thickness and contour as adjoining insulation; may be factory fabricated.
  - 5. Insert Material: Hydrous calcium silicate insulation or other heavy density insulating material suitable for the planned temperature range.
- I. Continue insulation through walls, sleeves, pipe hangers, and other pipe penetrations. Finish at supports, protrusions, and interruptions. At fire separations, see Section 078400.
- J. Pipe Exposed in Mechanical Equipment Rooms or Finished Spaces (less than 10 feet (3 meters) above finished floor): Finish with PVC jacket and fitting covers.
- K. Exterior Applications: Provide vapor barrier jacket. Insulate fittings, joints, and valves with insulation of like material and thickness as adjoining pipe, and finish with glass mesh reinforced vapor barrier cement. Cover with aluminum jacket with seams located on bottom side of horizontal piping.
- L. Buried Piping: Provide factory fabricated assembly with inner all-purpose service jacket with self-sealing lap, and asphalt impregnated open mesh glass fabric, with one mil, 0.001 inch (0.025 mm) thick aluminum foil sandwiched between three layers of bituminous compound; outer surface faced with a polyester film.

**END OF SECTION**

**SECTION 221005  
PLUMBING PIPING**

**PART 1 GENERAL**

**1.01 SECTION INCLUDES**

- A. Sanitary waste piping, buried within 5 feet (1500 mm) of building.
- B. Sanitary waste piping, above grade.
- C. Domestic water piping, buried within 5 feet (1500 mm) of building.
- D. Domestic water piping, above grade.
- E. Storm drainage piping, above grade.
- F. Pipe flanges, unions, and couplings.
- G. Pipe hangers and supports.
- H. Pipe sleeve-seal systems.
- I. Ball valves.
- J. Butterfly valves.
- K. Balancing valves.
- L. Flow-balancing valves.
- M. Pressure reducing valves.
- N. Pressure relief valves.
- O. Pressure-temperature valves.
- P. Strainers.

**1.02 SUBMITTALS**

- A. Product Data: Provide data on pipe materials, pipe fittings, valves, and accessories. Provide manufacturers catalog information. Indicate valve data and ratings.

**1.03 QUALITY ASSURANCE**

- A. Perform work in accordance with applicable codes.

**1.04 DELIVERY, STORAGE, AND HANDLING**

- A. Accept valves on site in shipping containers with labeling in place. Inspect for damage.
- B. Provide temporary protective coating on cast iron and steel valves.
- C. Provide temporary end caps and closures on piping and fittings. Maintain in place until installation.
- D. Protect piping systems from entry of foreign materials by temporary covers, completing sections of the work, and isolating parts of completed system.

**1.05 FIELD CONDITIONS**

- A. Do not install underground piping when bedding is wet or frozen.

**PART 2 PRODUCTS**

**2.01 GENERAL REQUIREMENTS**

- A. Potable Water Supply Systems: Provide piping, pipe fittings, and solder and flux (if used), that comply with NSF 61 and NSF 372 for maximum lead content; label pipe and fittings.

**2.02 SANITARY WASTE PIPING, BURIED WITHIN 5 FEET (1500 MM) OF BUILDING**

- A. Cast Iron Pipe: ASTM A74 extra heavy weight.
  - 1. Fittings: Cast iron.
  - 2. Joints: Hub-and-spigot, CISPI HSN compression type with ASTM C564 neoprene gaskets

- B. PVC Pipe: ASTM D2665 or ASTM D3034.
  - 1. Fittings: PVC.
  - 2. Joints: Solvent welded, with ASTM D2564 solvent cement.

### **2.03 SANITARY WASTE PIPING, ABOVE GRADE**

- A. Cast Iron Pipe: CISPI 301, hubless, service weight.
  - 1. Fittings: Cast iron.
  - 2. Joints: CISPI 310, neoprene gaskets and stainless steel clamp-and-shield assemblies.
- B. PVC Pipe: ASTM D2665.
  - 1. Fittings: PVC.
  - 2. Joints: Solvent welded, with ASTM D2564 solvent cement.

### **2.04 DOMESTIC WATER PIPING, BURIED WITHIN 5 FEET (1500 MM) OF BUILDING**

- A. Copper Pipe: ASTM B42, hard drawn.
  - 1. Fittings: ASME B16.18, cast copper alloy or ASME B16.22 wrought copper and bronze.
  - 2. Joints: ASTM B32, alloy Sn95 solder.
- B. Copper Pipe: ASTM B88 (ASTM B88M), Type K (A), Drawn (H).
  - 1. Fittings: ASME B16.18, cast copper alloy or ASME B16.22, wrought copper and bronze.
  - 2. Joints: ASTM B32, alloy Sn95 solder.

### **2.05 DOMESTIC WATER PIPING, ABOVE GRADE**

- A. Copper Pipe: ASTM B88 (ASTM B88M), Type L (B), Drawn (H).
  - 1. Fittings: ASME B16.18, cast copper alloy or ASME B16.22, wrought copper and bronze.
  - 2. Joints: ASTM B32, alloy Sn95 solder.
- B. Cross-Linked Polyethylene (PEX) Pipe: ASTM F876 or ASTM F877.
  - 1. Fittings: Brass and copper.
  - 2. Joints: Mechanical compression fittings.

### **2.06 STORM DRAINAGE PIPING, ABOVE GRADE**

- A. PVC Pipe: ASTM D2665.
  - 1. Fittings: PVC.
  - 2. Joints: Solvent welded, with ASTM D2564 solvent cement.

### **2.07 PIPE FLANGES, UNIONS, AND COUPLINGS**

- A. Unions for Pipe Sizes 3 inch (80 mm, DN) and Under:
  - 1. Ferrous Pipe: Class 150 malleable iron threaded unions.
  - 2. Copper Tube and Pipe: Class 150 bronze unions with soldered joints.
- B. Flanges for Pipe Sizes Over 1 inch (25 mm, DN):
  - 1. Ferrous Pipe: Class 150 malleable iron threaded or forged steel slip-on flanges; preformed neoprene gaskets.
  - 2. Copper Tube and Pipe: Class 150 slip-on bronze flanges; preformed neoprene gaskets.
- C. No-Hub Couplings:
  - 1. Testing: In accordance with ASTM C1277 and CISPI 310.
  - 2. Gasket Material: Neoprene complying with ASTM C564.
  - 3. Band Material: Stainless steel.
  - 4. Eyelet Material: Stainless steel.
- D. Shielded, Heavy Duty No-Hub Couplings:
  - 1. Testing: In accordance with ASTM C1540 and FM 1680.
  - 2. Gasket Material: Neoprene complying with ASTM C564.
  - 3. Band Material: Stainless steel.
  - 4. Eyelet Material: Stainless steel.
- E. Dielectric Connections: Union with galvanized or plated steel threaded end, copper solder end, water impervious isolation barrier.

## 2.08 PIPE HANGERS AND SUPPORTS

- A. See Section 220529 for additional requirements.
- B. Provide hangers and supports that comply with MSS SP-58.
  - 1. If type of hanger or support for a particular situation is not indicated, select appropriate type using MSS SP-58 recommendations.
  - 2. Overhead Supports: Individual steel rod hangers attached to structure or to trapeze hangers.
    - a. Cold and Hot Pipe Sizes 6 inch (150 mm, DN) and Larger: Double hangers.
  - 3. Trapeze Hangers: Welded steel channel frames attached to structure.
  - 4. Vertical Pipe Support: Steel riser clamp.
  - 5. Floor Supports: Concrete pier or steel pedestal with floor flange; fixture attachment.
  - 6. Rooftop Supports for Low-Slope Roofs: Steel pedestals with bases that rest on top of roofing membrane, not requiring any attachment to the roof structure and not penetrating the roofing assembly, with support fixtures as specified; and as follows:
    - a. Bases: High-density polypropylene.
    - b. Base Sizes: As required to distribute load sufficiently to prevent indentation of roofing assembly.
    - c. Steel Components: Stainless steel or carbon steel hot-dip galvanized after fabrication in accordance with ASTM A123/A123M.
    - d. Attachment and Support Fixtures: As recommended by manufacturer, same type as indicated for equivalent indoor hangers and supports; corrosion-resistant material.
    - e. Height: Provide minimum clearance of 6 inches (150 mm) under pipe to top of roofing.
- C. Plumbing Piping - Drain, Waste, and Vent:
  - 1. Hangers for Pipe Sizes 1/2 to 1-1/2 inch (15 to 40 mm, DN): Malleable iron, adjustable swivel, split ring.
  - 2. Hangers for Pipe Sizes 2 inch (50 mm, DN) and Over: Carbon steel, adjustable, clevis.
  - 3. Wall Support for Pipe Sizes to 3 inch (80 mm, DN): Cast iron hook.
  - 4. Wall Support for Pipe Sizes 4 inch (100 mm, DN) and Over: Welded steel bracket and wrought steel clamp.
  - 5. Floor Support: Cast iron adjustable pipe saddle, lock nut, nipple, floor flange, and concrete pier or steel support.
  - 6. Copper Pipe Support: Carbon steel ring, adjustable, copper plated.
- D. Plumbing Piping - Water:
  - 1. Hangers for Pipe Sizes 1/2 to 1-1/2 inch (15 to 40 mm, DN): Malleable iron, adjustable swivel, split ring.
  - 2. Hangers for Cold Pipe Sizes 2 inch (50 mm, DN) and Over: Carbon steel, adjustable, clevis.
  - 3. Hangers for Hot Pipe Sizes 2 to 4 inch (50 to 100 mm, DN): Carbon steel, adjustable, clevis.
  - 4. Hangers for Hot Pipe Sizes 6 inch (150 mm, DN) and Larger: Adjustable steel yoke, cast iron pipe roll, double hanger.
  - 5. Wall Support for Pipe Sizes Up to 3 inch (80 mm, DN): Cast iron hook.
  - 6. Wall Support for Pipe Sizes 4 inch (100 mm, DN) and Larger: Welded steel bracket and wrought steel clamp.
  - 7. Wall Support for Hot Pipe Sizes 6 inch (150 mm, DN) and Larger: Welded steel bracket and wrought steel clamp with adjustable steel yoke and cast iron pipe roll.
  - 8. Floor Support for Cold Pipe: Cast iron adjustable pipe saddle, lock nut, nipple, floor flange, and concrete pier or steel support.
  - 9. Floor Support for Hot Pipe Sizes to 4 inch (100 mm, DN): Cast iron adjustable pipe saddle, locknut, nipple, floor flange, and concrete pier or steel support.
  - 10. Floor Support for Hot Pipe Sizes 6 inch (150 mm, DN) and Larger: Adjustable cast iron pipe roll and stand, steel screws, and concrete pier or steel support.
  - 11. Copper Pipe Support: Carbon steel ring, adjustable, copper plated.

## 2.09 PIPE SLEEVE-SEAL SYSTEMS

- A. Modular Mechanical Seals:
  - 1. Elastomer-based interlocking links continuously fill annular space between pipe and wall-sleeve, wall or casing opening.
  - 2. Watertight seal between pipe and wall-sleeve, wall or casing opening.
  - 3. Size and select seal component materials in accordance to service requirements.
  - 4. Glass reinforced plastic pressure end plates.
- B. Wall Sleeve: PVC material with water-stop collar, and nailer end-caps.
- C. Sleeve-Forming Disk: Non-conductive plastic-based material, 3 inch (76.2 mm) thick.

## 2.10 BALL VALVES

- A. Construction, 4 inch (100 mm, DN) and Smaller: MSS SP-110, Class 150, 400 psi (2760 kPa) CWP, bronze or ductile iron body, 304 stainless steel or chrome plated brass ball, regular port, teflon seats and stuffing box ring, blow-out proof stem, lever handle with balancing stops, solder or threaded ends with union.

## 2.11 BUTTERFLY VALVES

- A. Construction 1-1/2 inch (40 mm, DN) and Larger: MSS SP-67, 200 psi (1380 kPa) CWP, cast or ductile iron body, nickel-plated ductile iron disc, resilient replaceable EPDM seat, wafer ends, extended neck, 10 position lever handle.
- B. Provide gear operators for valves 8 inches (150 mm, DN) and larger, and chain-wheel operators for valves mounted over 8 feet (2400 mm) above floor.

## 2.12 BALANCING VALVES

- A. Construction: Class 125, brass or bronze body with union on inlet and outlet, temperature and pressure test plug on inlet and outlet, blowdown/backflush drain.
- B. Manual Operated Y-Pattern Globe, Size 1/2 to 2 inch (15 to 50 mm, DN):
  - 1. Class 125, brass or bronze body, multi-turn handwheel, memory stop, variable orifice, soldered connections, dual PT (hot and cold pressure-temperature) test ports for 300 psi (2,068 kPa), minus 4 to 250 deg F (minus 20 to 121.1 deg C) WOG service.
- C. Automatic Flow Limiting Cartridge, Size 3/4 inch (20 mm, DN):
  - 1. Class 125, brass or bronze body, stainless steel cartridge, threaded connections with built-in union, dual PT (hot and cold pressure-temperature) test ports for 400 psi (2,758 kPa), 0.5 gpm (1.9 Lpm) WOG service.
- D. Automatic Flow Limiting Cartridge with Ball Valve, Size 1/2 to 1 inch (15 to 25 mm, DN):
  - 1. Class 125, brass or bronze body, stainless steel cartridge, leak-proof stem, threaded or soldered connections with built-in union, dual PT (hot and cold pressure-temperature) test ports for 400 psi (2,758 kPa), 0.25 to 1.5 gpm (0.9 to 5.6 Lpm) WOG service.
- E. Calibration: Control flow within five percent of selected rating, over operating pressure range of 10 times minimum pressure required for control, maximum minimum pressure 3.5 psi (24 kPa).

## 2.13 FLOW-BALANCING VALVES

- A. Construction: Class 125, Brass or bronze body with union on inlet and outlet, temperature and pressure test plug on inlet and outlet, blowdown/backflush drain.
- B. Calibration: Control flow within 5 percent of selected rating, over operating pressure range of 10 times minimum pressure required for control, maximum minimum pressure 3.5 psi (24 kPa).

## 2.14 PRESSURE REDUCING VALVES

- A. 2 inch (50 mm, DN) and Smaller:
  - 1. ASSE 1003, bronze body, stainless steel, and thermoplastic internal parts, fabric reinforced diaphragm, strainer, threaded single union ends.
  - 2. Pressure Reducing Pilot-Operator:
    - a. Operating Range: 5 to 50 psi (0.35 to 35 Bar).
    - b. Connected into brass or bronze pilot piping and fittings.

- c. Fixed flow restrictor, pressure gauges, and isolation valves.
- B. 2 inch (50 mm, DN) and Larger:
  - 1. ASSE 1003, cast iron body with interior lining complying with AWWA C550, bronze fitted, elastomeric diaphragm and seat disc, flanged.
  - 2. Pressure Reducing Pilot-Operator:
    - a. Operating Range: 5 to 50 psi (0.35 to 35 Bar).
    - b. Connected into brass or bronze pilot piping and fittings.
    - c. Fixed flow restrictor, strainer, pressure gauges, and isolation valves.
- C. Pilot Operated:
  - 1. Cast bronze, 1-1/2 to 8 inch, NPS (40 to 200 mm, DN) in size with flanged end connections. Rated for 300 psi (2,070 kPa) inlet pressure with outlet discharge field-set to system inlet pressure.
- D. Pressure Reducing Valves with Integral Back-Up:
  - 1. Size: 3 to 36 inch (80 to 900 mm, DN), Class 150 flange ends.
  - 2. ASSE 1003 and AWWA C550 compliant cast iron body, elastomeric diaphragm, seat disc and epoxy coated both internally and externally.
  - 3. Pressure Reducing Pilot-Operator:
    - a. Operating Range: 30 to 145 psi (2.07 to 10 Bar).
    - b. Connected into brass, bronze, or stainless steel pilot piping and fittings.
    - c. Precision fixed-flow restrictor, strainer, pressure gauges, and isolation valves,
    - d. Include pilot-side strainer on valve sizes above 4 inch (100 mm, DN).
- E. Pressure Reducing Valves with Low-Flow By-Pass:
  - 1. Size: 3 to 10 inch (80 to 250 mm, DN), Class 150 flange ends.
  - 2. ASSE 1003 and AWWA C550 compliant cast iron body, elastomeric diaphragm, seat disc and epoxy coated both internally and externally.
  - 3. Pressure Reducing Pilot-Operator:
    - a. Operating Range: 30 to 145 psi (2.07 to 10 Bar).
    - b. Direct Acting By-Pass Range: 5 to 50 psi (0.35 to 35 Bar).
    - c. Connected into brass, bronze, or stainless steel pilot piping and fittings.
    - d. Precision fixed-flow restrictor, strainer, pressure gauges, and isolation valves.
    - e. Include pilot-side strainer on valve sizes above 4 inch (100 mm, DN).
- F. Pressure Reducing and Pressure Sustaining Valves:
  - 1. Size: 1/2 to 40 inch (15 to 1,000 mm, DN), Class 150 flange ends.
  - 2. ASSE 1003 and AWWA C550 compliant cast iron body, elastomeric diaphragm, seat disc and epoxy coated both internally and externally.
  - 3. Pressure Reducing Pilot-Operator:
    - a. Operating Range: 5 to 50 psi (0.35 to 35 Bar).
    - b. Connected into brass, bronze, or stainless steel pilot piping and fittings.
    - c. Precision fixed-flow restrictor, pressure gauges, and isolation valves.
    - d. Include pilot-side strainer on valve sizes above 4 inch (100 mm, DN).
- G. Pressure Reducing and Sustaining Valves:
  - 1. Size: 1/2 to 40 inch (15 to 1,000 mm, DN), Class 150 flange ends.
  - 2. ASSE 1003 and AWWA C550 compliant cast iron body, elastomeric diaphragm, seat disc and epoxy coated both internally and externally.
  - 3. Dual Pressure Reducing Pilot-Operators:
    - a. Operating Range: 10 to 80 psi (0.7 to 5.5 Bar).
    - b. Connected into brass, bronze, or stainless steel piping and fittings.
    - c. Precision fixed-flow restrictor, pressure gauges, and isolation valves.
    - d. Include pilot-side strainer on valve sizes above 4 inch (100 mm, DN).

## 2.15 PRESSURE RELIEF VALVES

- A. ANSI Z21.22, AGA certified, bronze body, teflon seat, steel stem and springs, automatic, direct pressure actuated.



- B. Surge Anticipating, Pressure Relief Valves:
  1. Size: 1/2 to 40 inch (15 to 1,000 mm, DN).
  2. Class 150 flange ends; AWWA C550 compliant cast iron globe valve with elastomeric diaphragm, seat disc, and epoxy coated finish both internally and externally.
  3. Differential Pressure Based Dual Pilot-Operator:
    - a. Low-Surge Operating Range: 7 to 50 psi (0.48 to 3.5 bar).
    - b. High-Surge Operating Range: 10 to 80 psi (0.7 to 5.5 bar).
    - c. Connected into brass, bronze, or stainless steel pilot piping and fittings.
    - d. Precision fixed-flow restrictor, test needle-valve, strainer, swing check valve, pressure gauges, and isolation valves.

## **2.16 PRESSURE-TEMPERATURE VALVES**

- A. ANSI Z21.22, AGA certified, bronze body, teflon seat, stainless steel stem and springs, automatic, direct pressure actuated, temperature relief maximum 210 degrees F (98.9 degrees C), capacity ASME BPVC-IV certified and labelled.

## **2.17 STRAINERS**

- A. Size 1/2 inch (15 mm, DN) to 3 inch (80 mm, DN):
  1. Class 150, threaded forged bronze Y-pattern body, stainless steel perforated mesh screen with cap, and rated for 150 psi (1,034 kPa), 250 deg F (121.1 deg C) WOG service.
- B. Size 2 inch (50 mm, DN) and Smaller:
  1. Threaded brass body for 175 psi (1200 kPa) CWP, Y pattern with 1/32 inch (0.8 mm) stainless steel perforated screen.
  2. Class 150, threaded bronze body 300 psi (2070 kPa) CWP, Y pattern with 1/32 inch (0.8 mm) stainless steel perforated screen.
- C. Size 1-1/2 inch (40 mm, DN) to 4 inch (100 mm, DN):
  1. Class 125, flanged iron body, Y pattern with 1/16 inch (1.6 mm) stainless steel perforated screen.
- D. Size 5 inch (125 mm, DN) and Larger:
  1. Class 125, flanged iron body, basket pattern with 1/8 inch (3.2 mm) stainless steel perforated screen.

## **PART 3 EXECUTION**

### **3.01 EXAMINATION**

- A. Verify that excavations are to required grade, dry, and not over-excavated.

### **3.02 PREPARATION**

- A. Ream pipe and tube ends. Remove burrs. Bevel plain end ferrous pipe.
- B. Remove scale and dirt, on inside and outside, before assembly.
- C. Prepare piping connections to equipment with flanges or unions.

### **3.03 INSTALLATION**

- A. Install in accordance with manufacturer's instructions.
- B. Provide non-conducting dielectric connections wherever jointing dissimilar metals.
- C. Route piping in orderly manner and maintain gradient. Route parallel and perpendicular to walls.
- D. Install piping to maintain headroom, conserve space, and not interfere with use of space.
- E. Group piping whenever practical at common elevations.
- F. Install piping to allow for expansion and contraction without stressing pipe, joints, or connected equipment. See Section 220516.
- G. Provide clearance in hangers and from structure and other equipment for installation of insulation and access to valves and fittings.

- H. Provide access where valves and fittings are not exposed.
- I. Install vent piping penetrating roofed areas to maintain integrity of roof assembly.
- J. Provide support for utility meters in accordance with requirements of utility companies.
- K. Install water piping to ASME B31.9.
- L. Copper Pipe and Tube: Make soldered joints in accordance with ASTM B828, using specified solder, and flux meeting ASTM B813; in potable water systems use flux also complying with NSF 61 and NSF 372.
- M. PVC Pipe: Make solvent-welded joints in accordance with ASTM D2855.
- N. Sleeve pipes passing through partitions, walls, and floors.
- O. Inserts:
  - 1. Provide inserts for placement in concrete formwork.
  - 2. Provide inserts for suspending hangers from reinforced concrete slabs and sides of reinforced concrete beams.
  - 3. Provide hooked rod to concrete reinforcement section for inserts carrying pipe over 4 inches (100 mm, DN).
  - 4. Where concrete slabs form finished ceiling, locate inserts flush with slab surface.
  - 5. Where inserts are omitted, drill through concrete slab from below and provide through-bolt with recessed square steel plate and nut above slab.
- P. Pipe Hangers and Supports:
  - 1. Install in accordance with ASME B31.9.
  - 2. Support horizontal piping as indicated.
  - 3. Install hangers to provide minimum 1/2 inch (15 mm) space between finished covering and adjacent work.
  - 4. Place hangers within 12 inches (300 mm) of each horizontal elbow.
  - 5. Use hangers with 1-1/2 inch (40 mm) minimum vertical adjustment. Design hangers for pipe movement without disengagement of supported pipe.
  - 6. Support vertical piping at every other floor. Support riser piping independently of connected horizontal piping.
  - 7. Where several pipes can be installed in parallel and at same elevation, provide multiple or trapeze hangers.
  - 8. Provide copper plated hangers and supports for copper piping.
  - 9. Prime coat exposed steel hangers and supports. Hangers and supports located in crawl spaces, pipe shafts, and suspended ceiling spaces are not considered exposed.
  - 10. Support cast iron drainage piping at every joint.
- Q. Pipe Sleeve-Seal Systems:
  - 1. Install manufactured sleeve-seal systems in sleeves located in grade slabs and exterior concrete walls at piping entrances into building.
  - 2. Provide sealing elements of the size, quantity, and type required for the piping and sleeve inner diameter or penetration diameter.
  - 3. Locate piping in center of sleeve or penetration.
  - 4. Install field assembled sleeve-seal system components in annular space between sleeve and piping.
  - 5. Tighten bolting for a watertight seal.
  - 6. Install in accordance with manufacturer's recommendations.
- R. When installing more than one piping system material, ensure system components are compatible and joined to ensure the integrity of the system. Provide necessary joining fittings. Ensure flanges, union, and couplings for servicing are consistently provided.

### **3.04 APPLICATION**

- A. Install unions downstream of valves and at equipment or apparatus connections.
- B. Install ball or butterfly valves for shut-off and to isolate equipment, part of systems, or vertical risers.

- C. Install ball or butterfly valves for throttling, bypass, or manual flow control services.
- D. Provide lug end butterfly valves adjacent to equipment when provided to isolate equipment.
- E. Provide spring-loaded check valves on discharge of water pumps.
- F. Provide flow controls in water recirculating systems where indicated.

### **3.05 TOLERANCES**

- A. Drainage Piping: Establish invert elevations within 1/2 inch (10 mm) vertically of location indicated and slope to drain at minimum of 1/4 inch per foot (1:50) slope.

### **3.06 FIELD TESTS AND INSPECTIONS**

- A. Verify and inspect systems according to requirements by the Authority Having Jurisdiction. In the absence of specific test and inspection procedures proceed as indicated below.
- B. Domestic Water Systems:
  - 1. Perform hydrostatic testing for leakage prior to system disinfection.
  - 2. Test Preparation: Close each fixture valve or disconnect and cap each connected fixture.
  - 3. General:
    - a. Fill the system with water and raise static head to 10 psi (345 kPa) above service pressure. Minimum static head of 50 to 150 psi (345 to 1,034 kPa). As an exception, certain codes allow a maximum static pressure of 80 psi (551.6 kPa).
  - 4. Metal Piping Systems Subject to Freezing Conditions:
    - a. Inject 40 psi (275.8 kPa) of compressed air into piping to spot check for leaks with liquid soap. Document and repair leaks as necessary.
    - b. Raise injected compressed air pressure to 1.5 times rated service pressure or minimum pressure of 100 psi (689.5 kPa) for a duration of 2 hours and verify with a gauge that no perceptible pressure drop is measured.
- C. Test Results: Document and certify successful results, otherwise repair, document, and retest.

### **3.07 DISINFECTION OF DOMESTIC WATER PIPING SYSTEM**

- A. Prior to starting work, verify system is complete, flushed, and clean.
- B. Ensure acidity (pH) of water to be treated is between 7.4 and 7.6 by adding alkali (caustic soda or soda ash) or acid (hydrochloric).
- C. Inject disinfectant, free chlorine in liquid, powder, tablet, or gas form throughout system to obtain 50 to 80 mg/L residual.
- D. Bleed water from outlets to ensure distribution and test for disinfectant residual at minimum 15 percent of outlets.
- E. Maintain disinfectant in system for 24 hours.
- F. If final disinfectant residual tests less than 25 mg/L, repeat treatment.
- G. Flush disinfectant from system until residual equal to that of incoming water or 1.0 mg/L.
- H. Take samples no sooner than 24 hours after flushing, from 10 percent of outlets and from water entry, and analyze in accordance with AWWA C651.

### **3.08 SERVICE CONNECTIONS**

- A. Provide new sanitary sewer services. Before commencing work, check invert elevations required for sewer connections, confirm inverts and ensure that these can be properly connected with slope for drainage and cover to avoid freezing.
- B. Provide new water service complete with approved double check backflow preventer and water meter with by-pass valves, pressure reducing valve.

**END OF SECTION**

**SECTION 221006  
PLUMBING PIPING SPECIALTIES**

**PART 1 GENERAL**

**1.01 SECTION INCLUDES**

- A. Drains.
- B. Cleanouts.
- C. Hydrants.
- D. Washing machine outlet boxes.
- E. Ice maker outlet boxes.
- F. Backflow preventers.
- G. Double check valve assemblies.
- H. Water hammer arrestors.
- I. Mixing valves.
- J. Relief valves.
- K. Air vents.
- L. Floor drain trap seals.
- M. Exterior penetration accessories.

**1.02 SUBMITTALS**

- A. Product Data: Provide component sizes, rough-in requirements, service sizes, and finishes.

**PART 2 PRODUCTS**

**2.01 GENERAL REQUIREMENTS**

- A. Specialties in Potable Water Supply Systems: Provide products that comply with NSF 61 and NSF 372 for maximum lead content.

**2.02 DRAINS**

- A. Floor Drain:
  - 1. ASME A112.6.3; lacquered cast iron or stainless steel, two piece body with double drainage flange, weep holes, reversible clamping collar, and round, adjustable nickel-bronze strainer.

**2.03 CLEANOUTS**

- A. Cleanouts at Exterior Surfaced Areas:
  - 1. Round cast nickel bronze access frame and non-skid cover.
- B. Cleanouts at Exterior Unsurfaced Areas:
  - 1. Line type with lacquered cast iron body and round epoxy coated gasketed cover.
- C. Cleanouts at Interior Finished Floor Areas:
  - 1. Lacquered cast iron body with anchor flange, reversible clamping collar, threaded top assembly, and round gasketed scored cover in service areas and round gasketed depressed cover to accept floor finish in finished floor areas.
- D. Cleanouts at Interior Finished Wall Areas:
  - 1. Line type with lacquered cast iron body and round epoxy coated gasketed cover, and round stainless steel access cover secured with machine screw.
- E. Cleanouts at Interior Unfinished Accessible Areas: Caulked or threaded type.

**2.04 HYDRANTS**

- A. Wall Hydrants:
  - 1. ASSE 1019; freeze resistant, self-draining type with chrome-plated lockable recessed box hose thread spout, handwheel, and integral vacuum breaker.

## **2.05 WASHING MACHINE OUTLET BOXES**

- A. Description: Plastic preformed rough-in box with brass valves with single lever handle, socket for 2 inch (50 mm) waste, slip in finishing cover.

## **2.06 ICE MAKER OUTLET BOXES**

- A. Description: Plastic preformed square or round rough-in box with brass quarter-turn ball valve, and slip-in finishing cover.

## **2.07 BACKFLOW PREVENTERS**

- A. Reduced Pressure Backflow Preventer Assembly:
  - 1. ASSE 1013; low-lead cast bronze body and stainless steel springs; two independently operating, spring loaded check valves; diaphragm type differential pressure relief valve located between check valves; third check valve that opens under back pressure in case of diaphragm failure, and non-threaded vent outlet.
  - 2. Assembly with threaded full port ball valves.
  - 3. Maximum Working Parameters: 175 psi (1,207 kPa) at 180 degrees F (82.2 degrees C).
  - 4. Accessories: Provide air gap fitting, lead-free Y-strainer, and test cocks.

## **2.08 DOUBLE CHECK-VALVE ASSEMBLIES**

- A. Double Check Valve Assembly:
  - 1. ASSE 1015 and NSF 61 compliant lead-free bronze body assembly with corrosion resistant internal parts, stainless steel springs, intermediate atmospheric vent, two independently-operating check valves, and test-cock plug for horizontal or vertical mount.
  - 2. Assembly with threaded full port ball valves.
  - 3. Maximum Working Parameters: 175 psi (1,207 kPa) at 180 degrees F (82.2 degrees C).
  - 4. Accessories: Provide lead-free Y-strainer and pit-mounted protective enclosure.

## **2.09 WATER HAMMER ARRESTORS**

- A. Water Hammer Arrestors:
  - 1. Stainless steel construction, bellows type sized in accordance with PDI-WH 201, precharged suitable for operation in temperature range minus 100 to 300 degrees F (minus 73 to 149 degrees C) and maximum 250 psi (1700 kPa) working pressure.

## **2.10 MIXING VALVES**

- A. Thermostatic Master Mixing Valves:
  - 1. Valve: ASSE 1017, bronze or brass body; thermostatic element; corrosion- and lime-resistant internal components; integral locking temperature adjustment.
- B. Automatic Compensating Valves for Individual Showers and Tub and Shower Combinations:
  - 1. Valve: ASSE 1016, combination thermostatic and pressure balancing, bronze or brass body with inlet checkstops; integral volume and temperature control with adjustable high-temperature limit stop.

## **2.11 RELIEF VALVES**

- A. Bronze body, teflon seat, stainless steel stem and springs, automatic, direct pressure actuated, capacities ASME certified and labelled.

## **2.12 AIR VENTS**

- A. Manual Type: Short vertical sections of 2 inch (50 mm) diameter pipe to form air chamber, with 1/8 inch (3 mm) brass needle valve at top of chamber.
- B. Float Type:
  - 1. Brass or semi-steel body, copper, polypropylene, or solid non-metallic float, stainless steel valve and valve seat; suitable for system operating temperature and pressure; with isolating valve.
  - 2. Cast iron body and cover, float, bronze pilot valve mechanism suitable for system operating temperature and pressure; with isolating valve.
- C. Washer Type:

1. Brass with hygroscopic fiber discs, vent ports, adjustable cap for manual shut-off, and integral spring loaded ball check valve.

### **2.13 FLOOR DRAIN TRAP SEALS**

- A. Description: Push-fit EPDM or silicone fitting with a one-way membrane.

### **2.14 EXTERIOR PENETRATION ACCESSORIES**

- A. Flashing Panels for Exterior Wall Penetrations: Premanufactured components and accessories as required to preserve integrity of building envelope; suitable for conduits and facade materials to be installed.
- B. Sealing Systems for Roof Penetrations: Premanufactured components and accessories as required to preserve integrity of roofing system and maintain roof warranty; suitable for piping, cables, and roofing system to be installed; designed to accommodate existing penetrations where applicable.
- C. Plumbing Ventilation Thru Roof Accessories - Retrofit:
  1. Plumbing Pipe Extension Kit: Extends roof plumbing pipes above minimum clearance from roof surface per local codes and Authority Having Jurisdiction (AHJ).

## **PART 3 EXECUTION**

### **3.01 INSTALLATION**

- A. Install in accordance with manufacturer's instructions.
- B. Extend cleanouts to finished floor or wall surface. Lubricate threaded cleanout plugs with mixture of graphite and linseed oil. Ensure clearance at cleanout for rodding of drainage system.
- C. Encase exterior cleanouts in concrete flush with grade.
- D. Install floor cleanouts at elevation to accommodate finished floor.
- E. Install approved potable water protection devices on plumbing lines where contamination of domestic water may occur; on boiler feed water lines, janitor rooms, fire sprinkler systems, premise isolation, irrigation systems, flush valves, interior and exterior hose bibbs.
- F. Pipe relief from backflow preventer to nearest drain.
- G. Install water hammer arrestors complete with accessible isolation valve on hot and cold water supply piping to lavatory sinks, washing machine outlets, or other fixtures with fast-closing valves.

**END OF SECTION**

**SECTION 221429  
SUMP PUMPS**

**PART 1 GENERAL**

**1.01 SECTION INCLUDES**

- A. Submersible sump pumps.
- B. Sump basins and pits.

**1.02 SUBMITTALS**

- A. Product Data: Provide certified pump chart or curve with duty point marked over.

**1.03 QUALITY ASSURANCE**

- A. Certifications: UL (DIR) listed, classified, and suitable for the purpose specified and indicated.
- B. Identification: Provide pumps with manufacturer's name, model number, and rating/capacity identified by permanently attached label.

**1.04 DELIVERY, STORAGE, AND HANDLING**

- A. Provide temporary inlet and outlet caps. Maintain caps in place until installation.

**PART 2 PRODUCTS**

**2.01 SUBMERSIBLE SUMP PUMPS**

- A. General: Cast iron housing and base with oil-filled motor chamber, ball bearings, and mechanical seal.
- B. Impeller: Thermoplastic; open nonclog, corrosion resistant alloy steel shaft.
- C. Motor: Base mount, enclosed, lubricated oil-free, thermal-overload protected, continuous duty, permanent split capacitor with oil-resistant, three-prong connector, 10 foot (3 m) power cord.
- D. Controls: Integral, chemically-resistant, vertical plated-steel rod float switch. Cycle pump Off/On between 3 and 7.25 inch (7.6 to 18.4 cm) heights from bottom of pump.
- E. Solids Handling Capacity: Pass lint and other small solids up to 1/2 inch (15 mm) in size.
- F. Discharge Pipe Size: 1-1/2 inch (40 mm, DN), NPT, female.
- G. Maximum Water-Based Effluent Temperature: 120 degrees F (48,9 degrees C).
- H. Accessories: Provide full flow swing-type discharge check valve.

**2.02 SUMP BASINS AND PITS**

- A. Sump Basin:
  - 1. Below Ground Pipe Inlet: Molded or predrilled with seal, 4 inch (100 mm, DN).
  - 2. Basin Dimensions: 18 inch (45.7 cm) diameter, 30 inch (76.2 cm) deep.
  - 3. Basin Material: Polyethylene structural foam, heavy duty injection molded.
  - 4. Molded-Finish Requirements: Hard bottom, watertight, gas-tight and radon-tight molding.
  - 5. Maximum Effluent Temperature: Match or exceed maximum pump service temperature.
  - 6. Basin Cover:
    - a. Material: One-piece flat lid made of polyethylene with seal gasket.

**PART 3 EXECUTION**

**3.01 INSTALLATION**

- A. Install products with related fittings and accessories according to manufacturer instructions.
- B. Observe and provide incidentals required to complete installation in compliance with ICC (IPC).

**3.02 PROTECTION**

- A. Protect installed products from damage from subsequent construction operations.

**END OF SECTION**

**SECTION 223000  
PLUMBING EQUIPMENT**

**PART 1 GENERAL**

**1.01 SECTION INCLUDES**

- A. Residential electric water heaters.

**1.02 SUBMITTALS**

- A. Product Data:
  - 1. Provide dimension drawings of water heaters indicating components and connections to other equipment and piping.
  - 2. Provide electrical characteristics and connection requirements.

**1.03 QUALITY ASSURANCE**

- A. Certifications:
  - 1. Water Heaters: NSF approved.
  - 2. Electric Water Heaters: UL listed and labeled to UL 174.
  - 3. Products Requiring Electrical Connection: Listed and classified by Underwriters Laboratories Inc., as suitable for the purpose specified and indicated.

**1.04 DELIVERY, STORAGE, AND HANDLING**

- A. Provide temporary inlet and outlet caps. Maintain caps in place until installation.

**PART 2 PRODUCTS**

**2.01 WATER HEATERS**

- A. Residential Electric Water Heaters:
  - 1. Type: Automatic, electric, vertical storage.
  - 2. Minimum Efficiency Required: ASHRAE Std 90.1 I-P.
  - 3. Tank: Glass lined welded steel, thermally insulated with one inch (25 mm) thick glass fiber; encased in corrosion-resistant steel jacket; baked-on enamel finish.
  - 4. Controls: Automatic water thermostat with externally adjustable temperature range from 120 to 170 degrees F (49 to 77 degrees C), flanged or screw-in nichrome elements, enclosed controls and electrical junction box and operating light. Wire double element units so elements do not operate simultaneously.
  - 5. Accessories:
    - a. Water Connections: Brass.
    - b. Dip Tube: Brass.
    - c. Drain valve.
    - d. Anode: Magnesium.
    - e. Temperature and Pressure Relief Valve: ASME labeled.

**PART 3 EXECUTION**

**3.01 INSTALLATION**

- A. Install plumbing equipment in accordance with manufacturer's instructions, as required by code, and complying with conditions required for applicable certifications.
- B. Electrical Work: Provide automatic control and protective devices with associated wiring to interconnect related interfaced devices required for specified operation.
- C. Coordinate system, equipment, and piping work with applicable electrical, drain, and waste support interconnections as included or provided by other trades.

**END OF SECTION**



**SECTION 224000  
PLUMBING FIXTURES**

**PART 1 GENERAL**

**1.01 SECTION INCLUDES**

- A. Tank type water closets.
- B. Lavatories.
- C. Sinks.
- D. Under-lavatory pipe supply covers.
- E. Bathtubs and showers.
- F. Showers.
- G. Bi-level, electric water coolers.
- H. Mop sinks.

**1.02 SUBMITTALS**

- A. Product Data: Provide catalog illustrations of fixtures, sizes, rough-in dimensions, utility sizes, trim, and finishes.

**1.03 DELIVERY, STORAGE, AND HANDLING**

- A. Accept fixtures on-site in factory packaging. Inspect for damage.
- B. Protect installed fixtures from damage by securing areas and by leaving factory packaging in place to protect fixtures and prevent use.

**PART 2 PRODUCTS**

**2.01 GENERAL REQUIREMENTS**

- A. Potable Water Systems: Provide plumbing fittings and faucets that comply with NSF 61 and NSF 372 for maximum lead content; label pipe and fittings.

**2.02 REGULATORY REQUIREMENTS**

- A. Comply with applicable codes for installation of plumbing systems.
- B. Comply with UL (DIR) requirements.
- C. Perform work in accordance with local health department regulations.

**2.03 TANK TYPE WATER CLOSETS**

- A. Floor-Mounted Bowl:
  - 1. ASME A112.19.2; siphon jet, vitreous china, 16.5 inches (420 mm) high, close-coupled closet combination with elongated rim, insulated vitreous china closet tank with fittings and lever flushing valve, bolt caps, vandalproof cover locking device.
  - 2. Water Consumption: 1.28 gal (4.8 L) per flush, maximum.
  - 3. Handle Height: 44 inches (1117 mm) or less.
  - 4. Trapway Outlet: 4 inch (100 mm, DN).
- B. Toilet Seats:
  - 1. Plastic: Solid, white, elongated, closed front, slow-closing hinged seat cover, and brass bolts with covers.

**2.04 LAVATORIES**

- A. Wall-Hung Basin:
  - 1. Vitreous China, Grade A: ASME A112.19.2; white, rectangular commercial-grade sink with predrilled holes, rear-center drain, front overflow, and hanger. Size as indicated on drawings with 4-inch (100 mm) centerset spacing.
  - 2. Carrier:
    - a. ASME A112.6.1M; cast iron and steel frame with tubular legs, lugs for floor and wall attachment, concealed arm supports, bearing plate and studs.

- B. Drop-In Basin:
  1. Vitreous China: ASME A112.19.2; self-rimming, white, oval shape, front overflow, seal of putty, caulking, or concealed vinyl gasket, and white finish. Size as indicated on drawings with 4-inch (100 mm) centerset spacing.
- C. Supply Faucet:
  1. Deck Mounted Faucet Manufacturers:
  2. ASME A112.18.1; chrome plated combination supply fitting with pop-up waste, water economy aerator with maximum flow of 1.2 gpm (4.5 L/min), indexed handles.
  3. Single-Lever Handle, Supply Faucet: ASME A112.18.1; deck-mount, ceramic cartridge disc valve, and maximum flow of 1.2 gpm (4.5 L/min).
- D. Thermostatic Mixing Valve:
  1. ASSE 1070 listed with combination stop, strainer, and check valves, and flexible stainless steel connectors.
- E. Slip-joint P-trap.
- F. Braided hot and cold water supply lines.
- G. Chrome plated 17 gauge, 0.0538 inch (1.37 mm) brass P-trap with clean-out plug and arm with escutcheon.

## 2.05 SINKS

- A. Single Compartment Bowl
  1. ASME A112.19.3; 18 gauge, 0.050 inch (1.27 mm) thick, type 304 stainless steel, self-rimming and undercoated, with ledge back drilled for trim.
  2. Drain: 1-1/2 inch (38 mm) chromed brass.
  3. Drain: 3-1/2 inch (90 mm) crumb cup and tailpiece.
- B. Double Compartment Bowl:
  1. ASME A112.19.3; 18 gauge, 0.050 inch (1.27 mm) thick, type 304 stainless steel, self-rimming and undercoated, with ledge back drilled for trim.
  2. Drain: 1-1/2 inch (38 mm) chromed brass.
  3. Drain: 3-1/2 inch (90 mm) crumb cup and tailpiece.
- C. Kitchen Faucets:
  1. Single Handle Faucet with Side Spray:
    - a. Type: Deck-mount, swivel spout faucet with mounting plate.
    - b. Spray Type: Full stream spray at 1.5 gpm (5.6 L/min), maximum.
    - c. ASME A112.18.1, ADA Standards, and NSF 61 compliant assembly.
    - d. Materials: Ceramic disc-cartridge valve on brass body with polished chrome finish.
- D. Accessories: Provide braided water supply lines, slip-joint p-trap, and stainless steel basket strainer.

## 2.06 UNDER-LAVATORY PIPE SUPPLY COVERS

- A. General:
  1. Insulate exposed drainage piping including hot, cold and tempered water supplies under lavatories or sinks per ADA Standards.
  2. Adhesives, sewing threads and two ply laminated materials are prohibited.
  3. Exterior Surfaces: Smooth nonabsorbent with no finger recessed indentations for easy cleaning.
  4. Construction: 1/8 inch (3.2 mm) PVC with antimicrobial, antifungal and UV resistant properties.
    - a. Provide one piece injected molded design with internal bridge at top of J-bend to prevent separating.
    - b. Comply with ASTM E84 for flame and smoke development.
    - c. Comply with ASTM C1822 Type III for covers on accessible lavatory piping.
    - d. Comply with ASME A112.18.9 for covers on accessible lavatory piping.
    - e. Comply with ICC A117.1.

- f. Thermal Resistance: R value of 0.504 or lower when tested by ASTM C177.
  - g. Thermal Conductivity: K value of 0.358 or density of 21.61 pcf per ASTM C518.
  - h. Microbial and Fungal Resistance for Interior and Exterior: Comply with ASTM G21.
- 5. Color: High gloss white.
  - 6. Fasteners: Reusable, snap-locking fasteners with no sharp or abrasive external surfaces. No cable ties allowed.

## 2.07 BATHTUBS AND SHOWERS

- A. Bathtub:
  - 1. IAPMO Z124; molded glass fiber reinforced polyester, with slip-resistant bottom surface, contoured shape, color as selected.
  - 2. Length: 60 inches (1525 mm).
  - 3. Width: 30 inches (760 mm).
- B. Bath and Shower Trim: ASME A112.18.1; concealed shower and over rim supply with diverter spout, pressure balanced mixing valve, bent shower arm with adjustable spray ball joint showerhead with maximum 2.5 gpm (9.5 L/min) flow and escutcheon, lever operated pop-up waste and overflow.
- C. Thermostatic Mixing Valve:
  - 1. ASSE 1070 listed with combination stop, strainer, and check valves, and flexible stainless steel connectors.

## 2.08 SHOWERS

- A. Cabinet: IAPMO Z124 reinforced glass fiber with integral receptor, soap dish, removable chrome-plated strainer, tail piece, color as selected.
- B. Wall Mounted Shower Valve:
  - 1. Comply with ASME A112.18.1.
  - 2. Provide two-way, in-wall diverter valve body with integral thermostatic mixing valve to supply 1.5 gpm (5.6 L/min).
- C. Low-Flow Shower Head:
  - 1. ASME A112.18.1; chrome-plated vandal-proof institutional head with integral wall bracket, built-in 1.5 gpm (0.094 L/s) flow control.
- D. Hand-Held Shower Head:
  - 1. ASME A112.18.1, adjustable spray hand-held shower head with swivel fitting with ASSE 1014 backflow preventer.
  - 2. Provide pushbutton flow control.
  - 3. Include 60 inch (1525 mm) minimum flexible polished stainless steel hose and in-line vacuum breaker
  - 4. Provide 25 inch (635 mm) grab bar with sliding spray holder that locks at any height, allowing use of unit as either a hand-held spray or a fixed shower head.
- E. Thermostatic Mixing Valve:
  - 1. ASSE 1070 listed with combination stop, strainer, and check valves, and flexible stainless steel connectors.
- F. Pressure Balancing Valve:
  - 1. ASME A112.18.1, cast bronze, 6.3 gpm (23.8 L/min), rough-in ceramic disc cartridge shower valve with sweat connections.

## 2.09 BI-LEVEL, ELECTRIC WATER COOLERS

- A. Water Cooler: Bi-level, electric, mechanically refrigerated; surface mounted, ADA compliant; stainless steel top, vinyl on steel body, elevated anti-squirt bubbler with stream guard, automatic stream regulator, push button, mounting bracket; integral air cooled condenser and stainless steel grille.
  - 1. Capacity: 8 gph (30.3 Lph) of 50 degrees F (10 degrees C) water with inlet at 80 degrees F (27 degrees C) and room temperature of 90 degrees F (32 degrees C), when tested in accordance with ASHRAE Std 18.

2. Electrical: 115 VAC, 60 Hertz compressor, 6 foot (2 m) cord and plug for connection to electric wiring system including grounding connector.

B. Bottle Filler: Materials to match fountain.

## **2.10 MOP SINKS**

A. Material: Molded stone.

B. Type: Rectilinear.

C. Grid Strainer: Stainless steel; integral; removable.

D. Dimensions: As indicated on drawings.

E. Accessories:

1. 5 feet (1.5 m) of 1/2 inch (13 mm) diameter plain end reinforced plastic hose.
2. Hose clamp hanger.
3. Mop hanger.

## **2.11 HOSE BIB BOXES**

A. Material: 316 stainless steel.

B. Finish: Satin.

C. Mount in wall fully recessed.

D. Provide with NPT PVC ball valves and fittings.

E. Provide with internal hose drain bracket and waste outlet.

F. Provide with concealed hinge door and cam cylinder lock keyed alike.

## **PART 3 EXECUTION**

### **3.01 EXAMINATION**

- A. Verify that walls and floor finishes are prepared and ready for installation of fixtures.
- B. Verify that electric power is available and of the correct characteristics.
- C. Confirm that millwork is constructed with adequate provision for the installation of counter top lavatories and sinks.

### **3.02 PREPARATION**

- A. Rough-in fixture piping connections in accordance with minimum sizes indicated in fixture rough-in schedule for particular fixtures.

### **3.03 INSTALLATION**

- A. Install each fixture with trap, easily removable for servicing and cleaning.
- B. Provide chrome-plated rigid or flexible supplies to fixtures with stops, reducers, and escutcheons.
- C. Install components level and plumb.
- D. Install and secure fixtures in place with wall carriers and bolts.
- E. Solidly attach water closets to floor with lag screws. Lead flashing is not intended to hold fixture in place.

### **3.04 INTERFACE WITH WORK OF OTHER SECTIONS**

- A. Review millwork shop drawings. Confirm location and size of fixtures and openings before rough-in and installation.

### **3.05 ADJUSTING**

- A. Adjust stops or valves for intended water flow rate to fixtures without splashing, noise, or overflow.

### **3.06 CLEANING**

- A. Clean plumbing fixtures and equipment.

### **3.07 PROTECTION**

- A. Protect installed products from damage due to subsequent construction operations.
- B. Do not permit use of fixtures by construction personnel.
- C. Repair or replace damaged products before Date of Substantial Completion.

**END OF SECTION**

**SECTION 230529  
HANGERS AND SUPPORTS FOR HVAC PIPING AND EQUIPMENT**

**PART 1 GENERAL**

**1.01 SECTION INCLUDES**

- A. Support and attachment components.

**1.02 ADMINISTRATIVE REQUIREMENTS**

- A. Coordination:
  - 1. Coordinate sizes and arrangement of supports and bases with the actual equipment and components to be installed.
  - 2. Coordinate the work with other trades to provide additional framing and materials required for installation.
  - 3. Coordinate compatibility of support and attachment components with mounting surfaces at the installed locations.
  - 4. Coordinate the arrangement of supports with ductwork, piping, equipment and other potential conflicts installed under other sections or by others.
  - 5. Notify Architect of any conflicts with or deviations from Contract Documents. Obtain direction before proceeding with work.
- B. Sequencing:
  - 1. Do not install products on or provide attachment to concrete surfaces until concrete has fully cured.

**1.03 SUBMITTALS**

- A. Product Data: Provide manufacturer's standard catalog pages and data sheets for channel (strut) framing systems, nonpenetrating rooftop supports, post-installed concrete and masonry anchors, and thermal insulated pipe supports.

**1.04 QUALITY ASSURANCE**

- A. Comply with applicable building code.

**1.05 DELIVERY, STORAGE, AND HANDLING**

- A. Receive, inspect, handle, and store products in accordance with manufacturer's instructions.

**PART 2 PRODUCTS**

**2.01 SUPPORT AND ATTACHMENT COMPONENTS**

- A. General Requirements:
  - 1. Provide all required hangers, supports, anchors, fasteners, fittings, accessories, and hardware as necessary for the complete installation of plumbing work.
  - 2. Provide products listed, classified, and labeled as suitable for the purpose intended, where applicable.
  - 3. Where support and attachment component types and sizes are not indicated, select in accordance with manufacturer's application criteria as required for the load to be supported. Include consideration for vibration, equipment operation, and shock loads where applicable.
  - 4. Do not use wire, chain, perforated pipe strap, or wood for permanent supports unless specifically indicated or permitted.
  - 5. Steel Components: Use corrosion resistant materials suitable for the environment where installed.
    - a. Indoor Dry Locations: Use zinc-plated steel or approved equivalent unless otherwise indicated.
    - b. Outdoor and Damp or Wet Indoor Locations: Use galvanized steel, stainless steel, or approved equivalent unless otherwise indicated.
    - c. Zinc-Plated Steel: Electroplated in accordance with ASTM B633.
    - d. Galvanized Steel: Hot-dip galvanized after fabrication in accordance with ASTM A123/A123M or ASTM A153/A153M.

- B. Prefabricated Trapeze-Framed Metal Strut Systems:
  1. MFMA-4 compliant, pre-fabricated, MSS SP-58 type 59 continuous-slot metal strut channel with associated tracks, fittings, and related accessories.
  2. MFMA-4 compliant, prefabricated, side-loading continuous-slot metal strut channel bracket with associated tracks, fittings, and related accessories.
  3. Strut Channel or Bracket Material:
    - a. Indoor Dry Locations: Use painted steel, zinc-plated steel, or galvanized steel.
    - b. Outdoor and Damp or Wet Indoor Locations: Use galvanized steel.
  4. Minimum Channel Thickness: Steel sheet, 12 gauge, 0.1046 inch (2.66 mm).
  5. Minimum Channel Dimensions: 1-5/8 inch (41 mm) width by 13/16 inch (21 mm) height.
  6. Accessories: Provide bracket covers, cable basket clips, cable tray clips, clamps, conduit clamps, fire-retarding brackets, j-hooks, protectors, and vibration dampeners.
- C. Strut Channels:
  1. ASTM A653/A653M galvanized steel bracket with clamps for surface mounting of piping or plumbing equipment support.
  2. Channel or Bracket Kits: Include rods, brackets, end-fixed fittings, covers, clips, and other related hardware required to complete sectional trapeze section for piping or other support.
- D. Channel Nuts:
  1. Provide carbon steel channel nut with epoxy copper or zinc finish and long, regular, or short spring.
- E. Hanger Rods:
  1. Threaded zinc-plated steel unless otherwise indicated.
- F. Cable Hanging System Kits:
  1. Provide cable-wire in bulk or precut lengths with respective cable hangers as required to hold minimum weight of 120 lb (54.4 kg).
  2. Accessories: Provide brackets, clip or c-clip hangers, covers, and y-hook hangers.
- G. Thermal Insulated Pipe Supports:
  1. General Requirements:
    - a. Insulated pipe supports to be provided at hanger, support, and guide locations on pipe requiring insulation or additional support.
    - b. Surface Burning Characteristics: Flame spread index/smoke developed index of 5/30, maximum, when tested in accordance with ASTM E84 or UL 723.
    - c. Pipe supports to be provided for nominally sized, 1/2 to 30 inch (15 to 750 mm, DN) iron pipes.
    - d. Insulation inserts to consist of rigid polyisocyanurate (urethane) insulation surrounded by a 360 degree, PVC jacketing.
  2. PVC Jacket:
    - a. Pipe insulation protection shields to be provided with a ball bearing hinge and locking seam.
    - b. Minimum Service Temperature: Minus 40 degrees F (Minus 40 degrees C).
    - c. Maximum Service Temperature: 180 degrees F (82 degrees C).
    - d. Moisture Vapor Transmission: 0.0071 perm inch (0.0092 ng/Pa s m), when tested in accordance with ASTM E96/E96M.
    - e. Thickness: 60 mil (1.524 mm).
    - f. Connections: Brush on welding adhesive.
  3. Pipe insulation protection shields to be provided at the hanger points and guide locations on pipes requiring insulation as indicated on drawings.
- H. Pipe Supports:
  1. Material: ASTM A395/A395M ductile iron, ASTM A36/A36M carbon steel, ASTM A47/A47M malleable iron, ASTM A181/A181M forged steel, or ASTM A283/A283M steel.
  2. Liquid Temperatures Up To 122 degrees F (50 degrees C):
    - a. Overhead Support: MSS SP-58 Types 1, 3 through 12.

- b. Support From Below: MSS SP-58 Types 35 through 38.
  - 3. Operating Temperatures from 122 to 446 degrees F (50 to 230 degrees C):
    - a. Overhead Support: MSS SP-58 Type 1 or 3 through 12, with appropriate saddle of MSS SP-58 Type 40 for insulated pipe.
    - b. Roller Support: MSS SP-58 Types 41 or 43 through 46, with appropriate saddle of MSS SP-58 Type 39 for insulated pipe.
    - c. Sliding Support: MSS SP-58 Types 35 through 38.
- I. Roller Chairs:
  - 1. MSS SP-58 type 43 based on required load, nonconductive and corrosion resistant.
  - 2. Steel Yoke Type: MSS SP-58 type 44, vertically adjustable, nonconductive, and corrosion resistant.
  - 3. Material: Zinc plated ASTM A36/A36M carbon steel or ASTM A47/A47M malleable iron.
- J. Pipe Stanchions:
  - 1. Material: Malleable iron, ASTM A47/A47M; or carbon steel, ASTM A36/A36M.
  - 2. Provide coated or plated saddles to isolate steel hangers from dissimilar metal tube or pipe.
  - 3. For pipe runs, use stanchions of same type and material where vertical adjustment is required for stationary pipe.
- K. Beam Clamps:
  - 1. MSS SP-58 types 19 through 23, 25 or 27 through 30 based on required load.
  - 2. Beam C-Clamp: MSS SP-58 type 23, malleable iron and steel with plain, stainless steel, and zinc finish.
  - 3. Small or Junior Beam Clamp: MSS SP-58 type 19, malleable iron with plain finish. For inverted usage provide manufacturer listed size(s).
  - 4. Wide Mouth Beam Clamp: MSS SP-58 type 19, malleable iron with plain finish.
  - 5. Centerload Beam Clamp with Extension Piece: MSS SP-58 type 30, malleable iron with plain finish.
  - 6. FM (AG) and UL (DIR) Approved Beam Clamp: MSS SP-58 type 19, plain finish,
  - 7. Provide clamps with hardened steel cup-point set screws and lock-nuts for anchoring in place.
  - 8. Material: ASTM A395/A395M ductile iron, ASTM A36/A36M carbon steel, ASTM A47/A47M malleable iron, ASTM A181/A181M forged steel, or ASTM A283/A283M steel.
- L. Riser Clamps:
  - 1. For insulated pipe runs, provide two bolt-type clamps designed for installation under insulation.
  - 2. MSS SP-58 type 1 or 8, carbon steel or steel with epoxy plated, plain, stainless steel, or zinc plated finish.
  - 3. Medium Split Horizontal Pipe Clamp: MSS SP-58 type 4, carbon steel or stainless steel with epoxy plated, plain, stainless steel, or zinc plated finish.
  - 4. Copper Tube Pipe Clamp: MSS SP-58 type 8, epoxy plated copper.
  - 5. UL (DIR) listed: Pipe sizes 1/2 to 8 inch (15 to 200 mm, DN).
- M. U-Bolts:
  - 1. MSS SP-58 Type 24, carbon steel u-bolt for pipe support or anchoring.
- N. Offset Pipe Clamps: Double-leg design two-piece pipe clamp.
- O. Strut Clamps:
  - 1. Pipe Clamp: Two-piece rigid, universal, or outer diameter type, carbon steel with epoxy copper or zinc finish.
  - 2. Cushioned Pipe or Tubing Strut Clamp: Provide strut clamp with thermoplastic elastomer cushion having dielectric strength of 670 V/mil (26,398,000 V/m).
  - 3. Service Temperature Range: Minus 65 to 275 degrees F (Minus 53.8 to 135 degrees C).
- P. Insulation Clamps:
  - 1. Two bolt-type clamps designed for installation under insulation.



2. Material: Carbon steel with epoxy copper or zinc finish.
- Q. Pipe Hangers:
1. Split Ring Hangers:
    - a. Provide hinged split ring and yoke roller hanger with epoxy copper or plain finish.
    - b. Material: ASTM A47/A47M malleable iron or ASTM A36/A36M carbon steel.
    - c. Provide hanger rod and nuts of the same type and material for a given pipe run.
    - d. Provide coated or plated hangers to isolate steel hangers from dissimilar metal tube or pipe.
  2. Band Hangers, Adjustable:
    - a. MSS SP-58 Type 7 or 9, Zinc-plated ASTM A1011/A1011M steel or ASTM A653/A653M carbon steel.
  3. J-Hangers, Adjustable:
    - a. MSS SP-58 Type 5, Zinc-plated ASTM A1011/A1011M steel or ASTM A653/A653M carbon steel.
    - b. Felt-Lining: Provide for uninsulated pipe to reduce noise and prevent static issues.
  4. Swivel Ring Hangers, Adjustable:
    - a. MSS SP-58 Type 10, epoxy-painted, zinc-colored.
    - b. Material: ASTM A395/A395M ductile iron, ASTM A36/A36M carbon steel, ASTM A47/A47M malleable iron, ASTM A181/A181M forged steel, or ASTM A283/A283M steel.
    - c. FM (AG) and UL (DIR) listed for specific pipe size runs and loads.
    - d. Felt-Lining: Provide for uninsulated pipe to reduce noise and prevent static issues.
  5. Clevis Hangers, Adjustable:
    - a. Copper Tube: MSS SP-58 Type 1, epoxy-plated copper.
    - b. Felt-Lined: MSS SP-58 Type 1, zinc-plated, silicone-free carbon steel.
    - c. Light-Duty: MSS SP-58 Type 1, zinc-colored, epoxy plated.
    - d. Standard-Duty: MSS SP-58 Type 1, zinc-colored, epoxy plated.
    - e. UL (DIR) listed: Pipe sizes 2-1/2 to 8 inch (65 to 200 mm, DN).
    - f. FM (AG) listed: Pipe sizes 2-1/2 to 8 inch (65 to 200 mm, DN).
- R. Intermediate Pipe Guides:
1. Pipe Diameter 6 inch (150 mm, DN) and Smaller: Provide minimum clearance of 0.16 inch (4 mm).
  2. Pipe Sizes 8 inch (200 mm, DN): 0.625 inch (16 mm) U-bolt with double nuts providing minimum clearance of 0.28 inch (7 mm).
  3. Pipe Size 10 inch (250 mm, DN): 0.75 inch (19 mm) U-bolt.
  4. Pipe Sizes 12 to 16 inch (300 to 400 mm, DN): 0.875 inch (24 mm) U-bolt.
  5. Pipe Sizes 18 to 30 inch (450 to 750 mm, DN): 1 inch (25 mm) U-bolt.
  6. Use pipe clamps with oversize pipe sleeve that provides clearance around pipe.
- S. Pipe Alignment Guides: Galvanized steel.
1. Pipe Sizes 8 inch (200 mm, DN) and Smaller: Spider or sleeve type.
  2. Pipe Sizes 10 inch (250 mm, DN) and Larger: Roller type.
  3. Pipe Sizes 18 to 30 inch (450 to 750 mm, DN): 1 inch (25 mm) U-bolt.
- T. Dielectric Barriers: Provide between metallic supports and metallic piping and associated items of dissimilar type; acceptable dielectric barriers include rubber or plastic sheets or coatings attached securely to pipe or item.
- U. Nonpenetrating Rooftop Supports for Low-Slope Roofs:
1. Provide steel pedestals with thermoplastic or rubber base that rest on top of roofing membrane, not requiring any attachment to the roof structure and not penetrating the roofing assembly, with support fixtures as specified.
  2. Base Sizes: As required to distribute load sufficiently to prevent indentation of roofing assembly.
  3. Attachment/Support Fixtures: As recommended by manufacturer, same type as indicated for equivalent indoor hangers and supports.

4. Mounting Height: Provide minimum clearance of 6 inches (150 mm) under supported component to top of roofing.
- V. Pipe Shields for Insulated Piping:
1. MSS SP-58 Type 40, ASTM A1011/A1011M steel or ASTM A653/A653M carbon steel
  2. General Construction and Requirements:
    - a. Surface Burning Characteristics: Comply with ASTM E84 or UL 723.
    - b. Shields Material: UV-resistant polypropylene with glass fill.
    - c. Maximum Insulated Pipe Outer Diameter: 12-5/8 inch (321 mm).
    - d. Minimum Service Temperature: Minus 40 degrees F (Minus 40 degrees C).
    - e. Maximum Service Temperature: 178 degrees F (81 degrees C).
    - f. Pipe shields to be provided at hanger, support, and guide locations on pipe requiring insulation or additional support.
- W. Anchors and Fasteners:
1. Unless otherwise indicated and where not otherwise restricted, use the anchor and fastener types indicated for the specified applications.
  2. Concrete: Use preset concrete inserts, expansion anchors, or screw anchors.
  3. Solid or Grout-Filled Masonry: Use expansion anchors or screw anchors.
  4. Hollow Masonry: Use toggle bolts.
  5. Hollow Stud Walls: Use toggle bolts.
  6. Steel: Use beam-ceiling clamps, beam clamps, machine bolts, or welded threaded studs.
  7. Beam Ceiling Flanges: ASTM A47/A47M Grade 32510, malleable iron or stainless steel with copper, plain, stainless steel, or zinc finish.
  8. Sheet Metal: Use sheet metal screws.
  9. Wood: Use wood screws.
  10. Plastic and lead anchors are not permitted.
  11. Powder-actuated fasteners are not permitted.
  12. Hammer-driven anchors and fasteners are not permitted.
  13. Preset Concrete Inserts: Continuous metal channel (strut) and spot inserts specifically designed to be cast in concrete ceilings, walls, and floors.
    - a. Comply with MFMA-4.
    - b. Channel Material: Use galvanized steel.
    - c. Minimum Channel Thickness: Steel sheet, 12 gauge, 0.1046 inch (2.66 mm) minimum base metal thickness.
    - d. Manufacturer: Same as manufacturer of metal channel (strut) framing system.
  14. Post-Installed Concrete and Masonry Anchors: Evaluated and recognized by ICC Evaluation Service, LLC (ICC-ES) for compliance with applicable building code.
- X. Pipe Installation Accessories:
1. Copper Pipe Supports:
  2. Thermal Insulated, Surface-Mounted Pipe Supports:
    - a. Material: Carbon steel with epoxy copper or zinc finish.
    - b. Weather and UV light resistant foam, plastic, or rubber material with built-in strut.  
Maximum Load: 50 lb (22.7 kg) for single pipe or multiple landed on top strut.

## **PART 3 EXECUTION**

### **3.01 EXAMINATION**

- A. Verify that mounting surfaces are ready to receive support and attachment components.
- B. Verify that conditions are satisfactory for installation prior to starting work.

### **3.02 INSTALLATION**

- A. Install products in accordance with manufacturer's instructions.
- B. Install anchors and fasteners in accordance with ICC Evaluation Services, LLC (ICC-ES) evaluation report conditions of use where applicable.

- C. Provide independent support from building structure. Do not provide support from piping, ductwork, conduit, or other systems.
- D. Unless specifically indicated or approved by Architect, do not provide support from suspended ceiling support system or ceiling grid.
- E. Unless specifically indicated or approved by Architect, do not provide support from roof deck.
- F. Do not penetrate or otherwise notch or cut structural members without approval of Structural Engineer.
- G. Provide thermal insulated pipe supports complete with hangers and accessories. Install thermal insulated pipe supports during the installation of the piping system.
- H. Equipment Support and Attachment:
  - 1. Use metal fabricated supports or supports assembled from metal channel (strut) to support equipment as required.
  - 2. Use metal channel (strut) secured to studs to support equipment surface-mounted on hollow stud walls when wall strength is not sufficient to resist pull-out.
  - 3. Use metal channel (strut) to support surface-mounted equipment in wet or damp locations to provide space between equipment and mounting surface.
  - 4. Securely fasten floor-mounted equipment. Do not install equipment such that it relies on its own weight for support.
- I. Preset Concrete Inserts: Use manufacturer-provided closure strips to inhibit concrete seepage during concrete pour.
- J. Secure fasteners according to manufacturer's recommended torque settings.
- K. Remove temporary supports.

### **3.03 FIELD QUALITY CONTROL**

- A. Inspect support and attachment components for damage and defects.
- B. Repair cuts and abrasions in galvanized finishes using zinc-rich paint recommended by manufacturer. Replace components that exhibit signs of corrosion.
- C. Correct deficiencies and replace damaged or defective support and attachment components.

**END OF SECTION**

**SECTION 230593  
TESTING, ADJUSTING, AND BALANCING FOR HVAC**

**PART 1 GENERAL**

**1.01 SECTION INCLUDES**

- A. Testing, adjustment, and balancing of air systems.

**1.02 SUBMITTALS**

- A. Final Report: Indicate deficiencies in systems that would prevent proper testing, adjusting, and balancing of systems and equipment to achieve specified performance.
  - 1. Submit draft copies of report for review prior to final acceptance of Project. Provide final copies for Architect and for inclusion in operating and maintenance manuals.
  - 2. Include actual instrument list, with manufacturer name, serial number, and date of calibration.
  - 3. Form of Test Reports: Where the TAB standard being followed recommends a report format use that; otherwise, follow ASHRAE Std 111.
  - 4. Units of Measure: Report data in I-P (inch-pound) units only.

**PART 2 PRODUCTS - NOT USED**

**PART 3 EXECUTION**

**3.01 GENERAL REQUIREMENTS**

- A. Perform total system balance in accordance with one of the following:
  - 1. AABC (NSTSB), AABC National Standards for Total System Balance.
  - 2. ASHRAE Std 111, Practices for Measurement, Testing, Adjusting and Balancing of Building Heating, Ventilation, Air-Conditioning, and Refrigeration Systems.
  - 3. SMACNA (TAB).
- B. Begin work after completion of systems to be tested, adjusted, or balanced and complete work prior to Substantial Completion of the project.
- C. Where HVAC systems and/or components interface with life safety systems, including fire and smoke detection, alarm, and control, coordinate scheduling and testing and inspection procedures with the authorities having jurisdiction.
- D. TAB Agency Qualifications:
  - 1. Company specializing in the testing, adjusting, and balancing of systems specified in this section.
  - 2. Having minimum of three years documented experience.
  - 3. Certified by one of the following:
    - a. AABC, Associated Air Balance Council: [www.aabc.com/#sle](http://www.aabc.com/#sle); upon completion submit AABC National Performance Guaranty.
    - b. NEBB, National Environmental Balancing Bureau: [www.nebb.org/#sle](http://www.nebb.org/#sle).
    - c. TABBB, The Testing, Adjusting, and Balancing Bureau of National Energy Management Institute: [www.tabbcertified.org/#sle](http://www.tabbcertified.org/#sle).
- E. TAB Supervisor and Technician Qualifications: Certified by same organization as TAB agency.

**3.02 EXAMINATION**

- A. Verify that systems are complete and operable before commencing work. Ensure the following conditions:
  - 1. Systems are started and operating in a safe and normal condition.
  - 2. Temperature control systems are installed complete and operable.
  - 3. Proper thermal overload protection is in place for electrical equipment.
  - 4. Final filters are clean and in place. If required, install temporary media in addition to final filters.
  - 5. Duct systems are clean of debris.
  - 6. Fans are rotating correctly.
  - 7. Fire and volume dampers are in place and open.

8. Air coil fins are cleaned and combed.
9. Access doors are closed and duct end caps are in place.
10. Air outlets are installed and connected.
11. Duct system leakage is minimized.

B. Beginning of work means acceptance of existing conditions.

### **3.03 ADJUSTMENT TOLERANCES**

- A. Air Handling Systems: Adjust to within plus or minus 5 percent of design for supply systems and plus or minus 10 percent of design for return and exhaust systems.
- B. Air Outlets and Inlets: Adjust total to within plus 10 percent and minus 5 percent of design to space. Adjust outlets and inlets in space to within plus or minus 10 percent of design.

### **3.04 RECORDING AND ADJUSTING**

- A. Ensure recorded data represents actual measured or observed conditions.
- B. Permanently mark settings of valves, dampers, and other adjustment devices allowing settings to be restored. Set and lock memory stops.
- C. Mark on drawings the locations where traverse and other critical measurements were taken and cross reference the location in the final report.
- D. After adjustment, take measurements to verify balance has not been disrupted or that such disruption has been rectified.
- E. Leave systems in proper working order, replacing belt guards, closing access doors, closing doors to electrical switch boxes, and restoring thermostats to specified settings.

### **3.05 AIR SYSTEM PROCEDURE**

- A. Adjust air handling and distribution systems to provide required or design supply, return, and exhaust air quantities at site altitude.
- B. Make air quantity measurements in ducts by Pitot tube traverse of entire cross sectional area of duct.
- C. Measure air quantities at air inlets and outlets.
- D. Adjust distribution system to obtain uniform space temperatures free from objectionable drafts and noise.
- E. Use volume control devices to regulate air quantities only to extend that adjustments do not create objectionable air motion or sound levels. Effect volume control by duct internal devices such as dampers and splitters.
- F. Vary total system air quantities by adjustment of fan speeds. Provide drive changes required. Vary branch air quantities by damper regulation.
- G. Provide system schematic with required and actual air quantities recorded at each outlet or inlet.
- H. Measure static air pressure conditions on air supply units, including filter and coil pressure drops, and total pressure across the fan. Make allowances for 50 percent loading of filters.
- I. Adjust outside air automatic dampers, outside air, return air, and exhaust dampers for design conditions.
- J. Measure temperature conditions across outside air, return air, and exhaust dampers to check leakage.
- K. Where modulating dampers are provided, take measurements and balance at extreme conditions. Balance variable volume systems at maximum air flow rate, full cooling, and at minimum air flow rate, full heating.

**END OF SECTION**

**SECTION 230713  
DUCT INSULATION**

**PART 1 GENERAL**

**1.01 SECTION INCLUDES**

- A. Duct insulation.
- B. Duct liner.
- C. Weather barrier coatings.
- D. Jacketing and accessories.

**1.02 SUBMITTALS**

- A. Product Data: Provide product description, thermal characteristics, list of materials and thickness for each service, and locations.

**1.03 DELIVERY, STORAGE, AND HANDLING**

- A. Accept materials on site in original factory packaging, labelled with manufacturer's identification, including product density and thickness.
- B. Protect insulation from weather and construction traffic, dirt, water, chemical, and mechanical damage, by storing in original wrapping.

**1.04 FIELD CONDITIONS**

- A. Maintain ambient temperatures and conditions required by manufacturers of adhesives, mastics, and insulation cements.
- B. Maintain temperature during and after installation for minimum period of 24 hours.

**PART 2 PRODUCTS**

**2.01 REGULATORY REQUIREMENTS**

- A. Surface Burning Characteristics: Flame spread index/Smoke developed index of 25/50, maximum, when tested in accordance with ASTM E84 or UL 723.

**2.02 GLASS FIBER, FLEXIBLE**

- A. Insulation: ASTM C553; flexible, noncombustible blanket.
  - 1. K (Ksi) value: 0.36 at 75 degrees F (0.052 at 24 degrees C), when tested in accordance with ASTM C518.
  - 2. Maximum Service Temperature: 1,200 degrees F (649 degrees C).
  - 3. Maximum Water Vapor Absorption: 5.0 percent by weight.
- B. Vapor Barrier Jacket:
  - 1. Kraft paper with glass fiber yarn and bonded to aluminized film.
  - 2. Moisture Vapor Permeability: 0.02 perm inch (0.029 ng/(Pa s m)), when tested in accordance with ASTM E96/E96M.
  - 3. Secure with pressure-sensitive tape.
- C. Vapor Barrier Tape:
  - 1. Kraft paper reinforced with glass fiber yarn and bonded to aluminized film, with pressure-sensitive rubber-based adhesive.
- D. Indoor Vapor Barrier Mastic:
  - 1. Vinyl emulsion type acrylic or mastic, compatible with insulation, black color.
- E. Outdoor Vapor Barrier Mastic:
  - 1. Vinyl emulsion type acrylic or mastic, compatible with insulation, black color.
- F. Tie Wire: Annealed steel, 16 gauge, 0.0508 inch diameter (1.29 mm diameter).

**2.03 GLASS FIBER, RIGID**

- A. Insulation: ASTM C612; rigid, noncombustible blanket.

1. K (Ksi) Value: 0.24 at 75 degrees F (0.036 at 24 degrees C), when tested in accordance with ASTM C518.
  2. Maximum Service Temperature: 450 degrees F (232 degrees C).
  3. Maximum Water Vapor Absorption: 5.0 percent.
  4. Maximum Density: 8.0 pcf (128 kg/cu m).
- B. Vapor Barrier Jacket:
1. Kraft paper with glass fiber yarn and bonded to aluminized film.
  2. Moisture Vapor Permeability: 0.02 perm inch (0.029 ng/(Pa s m)), when tested in accordance with ASTM E96/E96M.
  3. Secure with pressure-sensitive tape.
- C. Vapor Barrier Tape:
1. Kraft paper reinforced with glass fiber yarn and bonded to aluminized film, with pressure-sensitive rubber-based adhesive.
- D. Protective Coating:
- E. Indoor Vapor Barrier Finish:
1. Cloth: Untreated; 9 oz/sq yd (305 g/sq m) weight, glass fabric.
  2. Vinyl emulsion type acrylic, compatible with insulation, white color.

#### **2.04 FLEXIBLE ELASTOMERIC CELLULAR INSULATION**

- A. Insulation: Preformed flexible elastomeric cellular rubber insulation complying with ASTM C534/C534M Grade 1, in sheet form.
1. Minimum Service Temperature: Minus 40 degrees F (Minus 40 degrees C).
  2. Maximum Service Temperature: 180 degrees F (82 degrees C).
  3. Connection: Waterproof vapor barrier adhesive.
- B. Elastomeric Foam Adhesive: Air dried, contact adhesive, compatible with insulation.
- C. Weather Barrier Coating: Air dried, contact adhesive, compatible with insulation and ASTM E84 compliant.

#### **2.05 WEATHER BARRIER COATINGS**

- A. Weather-Resistive Barrier Coating: Fire-resistive, UV resistant, water-based mastic for use over closed cell polyethylene and polyurethane foam insulation; applied with glass fiber or synthetic reinforcing mesh.
1. Surface Burning Characteristics: Flame spread index of 25 or less, smoke developed index of 450 or less, Class A, when tested in accordance with ASTM E84.
  2. Water Vapor Permeance: Greater than 1.0 perm (57 ng/(Pa s m)) in accordance with ASTM E96/E96M.
  3. Resistance to Fungal Growth: No growth when tested in accordance with ASTM D5590.
  4. Color: White.

#### **2.06 JACKETING AND ACCESSORIES**

- A. Canvas Jacket: UL listed 6 oz/sq yd (220 g/sq m) plain weave cotton fabric treated with dilute fire-retardant lagging adhesive.
1. Lagging Adhesive:
    - a. Compatible with insulation.
- B. Mineral Fiber (Outdoor) Jacket: Asphalt impregnated and coated sheet, 50 lb/square (2.45 kg/sq m).
- C. Aluminum Jacket:
1. Comply with ASTM B209/B209M, Temper H14, minimum thickness of 0.016 inch (0.41 mm) with factory-applied polyethylene and kraft paper moisture barrier on the inside surface.
  2. Thickness: 0.016 inch (0.40 mm) sheet.
  3. Finish: Smooth.
  4. Joining: Longitudinal slip joints and 2 inch (50 mm) laps.

5. Fittings: 0.016 inch (0.40 mm) thick die-shaped fitting covers with factory-attached protective liner.
  6. Metal Jacket Bands: 3/8 inch (10 mm) wide; 0.015 inch (0.38 mm) thick aluminum.
- D. Flexible Weather-Proofing Outdoor Jacket: Self-healing, field-applied outdoor cladding.
1. Material: Aluminum foil/polymer laminate with rubberized asphalt layer and acrylic adhesive.
  2. Thickness: 34 mil, 0.034 inch (0.86 mm).
  3. Finish: Embossed.
  4. Color: Silver.
  5. Water Vapor Transmission: 0.002 perm inch (0.0029 ng/(Pa s m)), maximum, when tested in accordance with ASTM E96/E96M.
  6. Mold Resistance: Pass when tested in accordance with ASTM C1338.
  7. Emissivity: 0.30 when tested in accordance with ASTM C1371.
- E. Reinforced Tape:
1. FSK tape suitable for sealing seams between insulation, insulated elbows, and fittings resulting in a tight, smooth surface without wrinkles.
  2. Comply with UL 723 or ASTM E84.
  3. Moisture Vapor Permeability: 0.00 perm inch (0.00 ng/(Pa s m)), when tested in accordance with ASTM E96/E96M.
  4. Finish: Match insulation.
- F. Plain Foil Tape:
1. Aluminum foil with pressure-sensitive adhesive on paper release liner.
  2. Finish: Plain foil.
- G. UL181 Tape for Rigid and Flexible Ductwork:
1. Comply with UL 181A for rigid ductwork.
  2. Comply with UL 181B for flexible ductwork.
  3. Aluminum foil coated with pressure-sensitive adhesive on paper release liner.
  4. Foil tape suitable for sealing seams between insulation, insulated elbows, and fittings resulting in a tight, smooth surface without wrinkles.
  5. Finish: Printed with UL Listing for identification.

## 2.07 DUCT LINER

- A. Note: Choose the liner type - Elastomeric Foam, Glass Fiber, or Phenolic Foam.
- B. Elastomeric Foam Insulation: Preformed flexible elastomeric cellular rubber insulation complying with ASTM C534/C534M Grade 1, in sheet form.
1. Minimum Service Temperature: Minus 40 degrees F (Minus 40 degrees C).
  2. Maximum Service Temperature: 180 degrees F (82 degrees C).
  3. Fungal Resistance: No growth when tested according to ASTM G21.
  4. Apparent Thermal Conductivity: Maximum of 0.28 at 75 degrees F (0.045 at 24 degrees C).
  5. Minimum Noise Reduction Coefficients:
    - a. 1/2 inch (13 mm) Thickness: 0.30.
    - b. 1 inch (25 mm) Thickness: 0.40.
    - c. 1-1/2 inches (40 mm) Thickness: 0.50.
    - d. 2 inch (50 mm) Thickness: 0.60.
  6. Erosion Resistance: Does not show evidence of breaking away, flaking off, or delamination at velocities of 10,000 fpm (50.8 m/s) when tested in accordance with ASTM C1071.
  7. Connection: Waterproof vapor barrier adhesive.
- C. Elastomeric Foam Adhesive: Air dried, contact adhesive, compatible with insulation. Comply with ASTM C916.
- D. Adhesive: Waterproof, fire-retardant type, ASTM C916.
- E. Liner Fasteners: Galvanized steel, self-adhesive pad with integral head.



## **PART 3 EXECUTION**

### **3.01 EXAMINATION**

- A. Test ductwork for design pressure prior to applying insulation materials.
- B. Verify that surfaces are clean, foreign material removed, and dry.

### **3.02 INSTALLATION**

- A. Install in accordance with manufacturer's instructions.
- B. Insulated Ducts Conveying Air Below Ambient Temperature:
  - 1. Provide insulation with vapor barrier jackets.
  - 2. Finish with tape and vapor barrier jacket.
  - 3. Continue insulation through walls, sleeves, hangers, and other duct penetrations.
  - 4. Insulate entire system, including fittings, joints, flanges, fire dampers, flexible connections, and expansion joints.
- C. Insulated Ducts Conveying Air Above Ambient Temperature:
  - 1. Provide with or without standard vapor barrier jacket.
  - 2. Insulate fittings and joints. Where service access is required, bevel and seal ends of insulation.
- D. Ducts Exposed in Mechanical Equipment Rooms or Finished Spaces (below 10 feet above finished floor) ((below 3 meters above finished floor)): Finish with aluminum jacket.
- E. Duct and Plenum Liner Application:
  - 1. Adhere insulation with adhesive for 90 percent coverage.
  - 2. Secure insulation with mechanical liner fasteners. Refer to SMACNA (DCS) for spacing.
  - 3. Seal and smooth joints. Seal and coat transverse joints.
  - 4. Seal liner surface penetrations with adhesive.
  - 5. Duct dimensions indicated are net inside dimensions required for airflow. Increase duct size to allow for insulation thickness.

**END OF SECTION**

**SECTION 230716  
HVAC EQUIPMENT INSULATION**

**PART 1 GENERAL**

**1.01 SECTION INCLUDES**

- A. Equipment insulation.
- B. Weather barrier coatings.
- C. Jacketing and accessories.

**1.02 SUBMITTALS**

- A. Product Data: Provide product description, thermal characteristics, list of materials and thickness for equipment scheduled.

**1.03 DELIVERY, STORAGE, AND HANDLING**

- A. Accept materials on site in original factory packaging, labeled with manufacturer's identification, including product density and thickness.
- B. Protect insulation from weather and construction traffic, dirt, water, chemical, and mechanical damage, by storing in original wrapping.

**1.04 FIELD CONDITIONS**

- A. Maintain ambient temperatures and conditions required by manufacturers of adhesives, mastics, and insulation cements.
- B. Maintain temperature during and after installation for minimum period of 24 hours.

**PART 2 PRODUCTS**

**2.01 REGULATORY REQUIREMENTS**

- A. Surface Burning Characteristics: Flame spread index/Smoke developed index of 25/50, maximum, when tested in accordance with ASTM E84 or UL 723.

**2.02 GLASS FIBER, FLEXIBLE**

- A. Insulation: ASTM C553; flexible, noncombustible.
  - 1. K (Ksi) Value: 0.36 at 75 degrees F (0.052 at 24 degrees C), when tested in accordance with ASTM C177 or ASTM C518.
  - 2. Maximum Service Temperature: 1,000 degrees F (538 degrees C).
  - 3. Maximum Water Vapor Absorption: 5.0 percent by weight.
- B. Vapor Barrier Jacket: Kraft paper reinforced with glass fiber yarn and bonded to aluminized film.
  - 1. Moisture Vapor Permeability: 0.02 perm inch (0.029 ng/(Pa s m)), when tested in accordance with ASTM E96/E96M.
  - 2. Secure with self-sealing longitudinal laps and butt strips.
  - 3. Secure with outward clinch expanding staples and vapor barrier mastic.
- C. Tie Wire: 0.048 inch (1.22 mm) stainless steel with twisted ends on maximum 12 inch (300 mm) centers.
- D. Vapor Barrier Lap Adhesive: Compatible with insulation.
- E. Insulating Cement/Mastic: ASTM C195; hydraulic setting on mineral wool.

**2.03 GLASS FIBER, RIGID**

- A. Insulation: ASTM C612 or ASTM C592; rigid, noncombustible.
  - 1. K (Ksi) Value: 0.25 at 75 degrees F (0.036 at 24 degrees C), when tested in accordance with ASTM C177 or ASTM C518.
  - 2. Maximum Service Temperature: 1,200 degrees F (649 degrees C).
  - 3. Maximum Water Vapor Absorption: 5.0 percent by weight.
  - 4. Maximum Density: 8.0 pcf (128 kg/cu m).
- B. Vapor Barrier Jacket:

1. Kraft paper reinforced with glass fiber yarn and bonded to aluminized film.
  2. Moisture Vapor Permeability: 0.02 perm inch (0.029 ng/(Pa s m)), when tested in accordance with ASTM E96/E96M.
  3. Secure with self-sealing longitudinal laps and butt strips.
  4. Secure with outward clinch expanding staples and vapor barrier mastic.
- C. Facing: 1 inch (25 mm) galvanized steel hexagonal wire mesh stitched on one face of insulation.
- D. Vapor Barrier Lap Adhesive: Compatible with insulation.
- E. Insulating Cement/Mastic: ASTM C195; hydraulic setting on mineral wool.

#### **2.04 FLEXIBLE ELASTOMERIC CELLULAR INSULATION**

- A. Insulation: Preformed flexible elastomeric cellular rubber insulation complying with ASTM C534/C534M Grade 1, in sheet form.
1. Minimum Service Temperature: Minus 40 degrees F (Minus 40 degrees C).
  2. Maximum Service Temperature: 220 degrees F (104 degrees C).
  3. Connection: Waterproof vapor barrier adhesive.
- B. Elastomeric Foam Adhesive: Air dried, contact adhesive, compatible with insulation.

#### **2.05 WEATHER BARRIER COATINGS**

- A. Weather-Resistive Barrier Coating: Fire-resistive, UV resistant, water-based mastic for use over closed cell polyethylene and polyurethane foam insulation; applied with glass fiber or synthetic reinforcing mesh.
1. Surface Burning Characteristics: Flame spread index of 25 or less, smoke developed index of 450 or less, Class A, when tested in accordance with ASTM E84.
  2. Water Vapor Permeance: Greater than 1.0 perm (57 ng/(Pa s m)) in accordance with ASTM E96/E96M.
  3. Resistance to Fungal Growth: No growth when tested in accordance with ASTM D5590.
  4. Color: White.

#### **2.06 JACKETING AND ACCESSORIES**

- A. PVC Plastic:
1. Jacket: Sheet material, off-white color.
    - a. Minimum Service Temperature: Minus 40 degrees F (Minus 40 degrees C).
    - b. Maximum Service Temperature: 150 degrees F (66 degrees C).
    - c. Moisture Vapor Permeability: 0.02 perm inch (0.029 ng/(Pa s m)), when tested in accordance with ASTM E96/E96M.
    - d. Thickness: 10 mil, 0.010 inch (0.25 mm).
    - e. Connections: Brush on welding adhesive.
  2. Covering Adhesive Mastic: Compatible with insulation.
- B. Canvas Jacket: UL listed 6 oz/sq yd (220 g/sq m) plain weave cotton fabric treated with dilute fire-retardant lagging adhesive.
1. Lagging Adhesive: Compatible with insulation.
- C. Aluminum Jacket:
1. Comply with ASTM B209/B209M, Temper H14, minimum thickness of 0.016 inch (0.41 mm) with factory-applied polyethylene and kraft paper moisture barrier on the inside surface.
  2. Thickness: 0.016 inch (0.40 mm) sheet.
  3. Finish: Smooth.
  4. Joining: Longitudinal slip joints and 2 inch (50 mm) laps.
  5. Fittings: 0.016 inch (0.40 mm) thick die-shaped fitting covers with factory-attached protective liner.
  6. Metal Jacket Bands: 3/8 inch (10 mm) wide; 0.015 inch (0.38 mm) thick aluminum.
- D. Reinforced Tape:

1. FSK tape suitable for sealing seams in insulation, insulated pipe bends, and fittings resulting in a tight, smooth surface without wrinkles.
  2. Comply with UL 723 or ASTM E84.
  3. Moisture Vapor Permeability: 0.00 perm inch (0.00 ng/(Pa s m)), when tested in accordance with ASTM E96/E96M.
  4. Finish: Match insulation.
- E. Plain Foil Tape:
1. Aluminum foil with pressure-sensitive adhesive on paper release liner.
  2. Finish: Plain foil.

## **PART 3 EXECUTION**

### **3.01 EXAMINATION**

- A. Verify that equipment has been tested before applying insulation materials.
- B. Verify that surfaces are clean and dry, with foreign material removed.

### **3.02 INSTALLATION**

- A. Install in accordance with manufacturer's instructions.
- B. Factory Insulated Equipment: Do not insulate.
- C. Exposed Equipment: Locate insulation and cover seams in least visible locations.
- D. Apply insulation close to equipment by grooving, scoring, and beveling insulation. Fasten insulation to equipment with studs, pins, clips, adhesive, wires, or bands.
- E. Fill joints, cracks, seams, and depressions with bedding compound to form smooth surface. On cold equipment, use vapor barrier cement.
- F. Insulated equipment containing fluids below ambient temperature; insulate entire system.
- G. Fiber glass insulated equipment containing fluids below ambient temperature; provide vapor barrier jackets, factory-applied or field-applied. Finish with glass cloth and vapor barrier adhesive.
- H. For hot equipment containing fluids 140 degrees F (60 degrees C) or less, do not insulate flanges and unions, but bevel and seal ends of insulation.
- I. For hot equipment containing fluids over 140 degrees F (60 degrees C), insulate flanges and unions with removable sections and jackets.
- J. Fiber glass insulated equipment containing fluids above ambient temperature; provide standard jackets, with or without vapor barrier, factory-applied or field-applied. Finish with glass cloth and adhesive.
- K. Inserts and Shields:
  1. Application: Equipment 1-1/2 inches (40 mm) diameter or larger.
  2. Shields: Galvanized steel between hangers and inserts.
  3. Insert Location: Between support shield and equipment and under the finish jacket.
  4. Insert Configuration: Minimum 6 inches (150 mm) long, of same thickness and contour as adjoining insulation; may be factory fabricated.
  5. Insert Material: Hydrous calcium silicate insulation or other heavy density insulating material suitable for the planned temperature range.
- L. Finish insulation at supports, protrusions, and interruptions.
- M. Equipment in Mechanical Equipment Rooms or Finished Spaces: Finish with PVC jacket and fitting covers.
- N. Exterior Applications:
  1. Provide vapor barrier jacket or finish with glass mesh reinforced vapor barrier cement.
  2. Cover with aluminum.
- O. Cover glass fiber insulation with metal mesh and finish with heavy coat of insulating cement.
- P. Nameplates and ASME Stamps: Bevel and seal insulation around; do not insulate over.

- Q. Equipment Requiring Access for Maintenance, Repair, or Cleaning: Install insulation so it can be easily removed and replaced without damage.

**END OF SECTION**

**SECTION 230719  
HVAC PIPING INSULATION**

**PART 1 GENERAL**

**1.01 SECTION INCLUDES**

- A. Piping insulation.
- B. Weather barrier coatings.
- C. Jacketing and accessories.
- D. Engineered wall outlet seals and refrigerant piping insulation protection.

**1.02 SUBMITTALS**

- A. Product Data: Provide product description, thermal characteristics, list of materials and thickness for each service, and locations.

**1.03 DELIVERY, STORAGE, AND HANDLING**

- A. Accept materials on site, labeled with manufacturer's identification, product density, and thickness.

**1.04 FIELD CONDITIONS**

- A. Maintain ambient conditions required by manufacturers of each product.
- B. Maintain temperature before, during, and after installation for minimum of 24 hours.

**PART 2 PRODUCTS**

**2.01 REGULATORY REQUIREMENTS**

- A. Surface Burning Characteristics: Flame spread index/Smoke developed index of 25/50, maximum, when tested in accordance with ASTM E84 or UL 723.

**2.02 GLASS FIBER, FLEXIBLE**

- A. Insulation: ASTM C553; flexible, noncombustible blanket.
  - 1. K (Ksi) Value: 0.36 at 75 degrees F (0.052 at 24 degrees C), when tested in accordance with ASTM C518.
  - 2. Maximum Service Temperature: 1,200 degrees F (649 degrees C).
  - 3. Maximum Water Vapor Absorption: 5.0 percent by weight.
- B. Vapor Barrier Jacket:
  - 1. Kraft paper with glass fiber yarn and bonded to aluminized film.
  - 2. Moisture Vapor Permeability: 0.02 perm inch (0.029 ng/(Pa s m)), when tested in accordance with ASTM E96/E96M.
  - 3. Secure with pressure-sensitive tape.
- C. Vapor Barrier Tape:
  - 1. Kraft paper reinforced with glass fiber yarn and bonded to aluminized film with pressure-sensitive rubber-based adhesive.
- D. Outdoor Vapor Barrier Mastic:
  - 1. Vinyl emulsion type acrylic or mastic, compatible with insulation, black color.
- E. Tie Wire: Annealed steel, 16 gauge, 0.0508 inch diameter (1.29 mm diameter).

**2.03 GLASS FIBER, RIGID**

- A. Insulation: ASTM C547 and ASTM C795; rigid molded, noncombustible.
  - 1. K (Ksi) Value: ASTM C177, 0.24 at 75 degrees F (0.035 at 24 degrees C).
  - 2. Maximum Service Temperature: 850 degrees F (454 degrees C).
  - 3. Maximum Moisture Absorption: 0.2 percent by volume.
- B. Vapor Barrier Jacket: White kraft paper with glass fiber yarn, bonded to aluminized film; moisture vapor transmission when tested in accordance with ASTM E96/E96M of 0.02 perm-inches (0.029 ng/(Pa s m)).

- C. Tie Wire: 0.048 inch (1.22 mm) stainless steel with twisted ends on maximum 12 inch (300 mm) centers.
- D. Vapor Barrier Lap Adhesive: Compatible with insulation.
- E. Insulating Cement/Mastic: ASTM C195; hydraulic setting on mineral wool.
- F. Fibrous Glass Fabric:
  - 1. Cloth: Untreated; 9 oz/sq yd (305 g/sq m) weight.
  - 2. Blanket: 1.0 pcf (16 kg/cu m) density.
  - 3. Weave: 5 by 5.
- G. Indoor Vapor Barrier Finish:
  - 1. Cloth: Untreated; 9 oz/sq yd (305 g/sq m) weight.
  - 2. Vinyl emulsion type acrylic, compatible with insulation, black color.
- H. Outdoor Vapor Barrier Mastic: Vinyl emulsion type acrylic or mastic, compatible with insulation, white color.
- I. Insulating Cement: ASTM C449.

#### **2.04 FLEXIBLE ELASTOMERIC CELLULAR INSULATION**

- A. Insulation: Preformed flexible elastomeric cellular rubber insulation complying with ASTM C534/C534M Grade 1; use molded tubular material wherever possible.
  - 1. Minimum Service Temperature: Minus 40 degrees F (Minus 40 degrees C).
  - 2. Maximum Service Temperature: 180 degrees F (82 degrees C).
  - 3. Connection: Waterproof vapor barrier adhesive.
- B. Elastomeric Foam Adhesive: Air dried, contact adhesive, compatible with insulation.
- C. Weather Barrier Coating: Air dried, contact adhesive, compatible with insulation and ASTM E84 compliant.

#### **2.05 WEATHER BARRIER COATINGS**

- A. Weather-Resistive Barrier Coating: Fire-resistive, UV resistant, water-based mastic for use over closed cell polyethylene and polyurethane foam insulation; applied with glass fiber or synthetic reinforcing mesh.
  - 1. Surface Burning Characteristics: Flame spread index of 25 or less, smoke developed index of 450 or less, Class A, when tested in accordance with ASTM E84.
  - 2. Water Vapor Permeance: Greater than 1.0 perm (57 ng/(Pa s m)) in accordance with ASTM E96/E96M.
  - 3. Resistance to Fungal Growth: No growth when tested in accordance with ASTM D5590.
  - 4. Color: White.

#### **2.06 JACKETING AND ACCESSORIES**

- A. PVC Plastic.
  - 1. Jacket: One piece molded type fitting covers and sheet material, off-white color.
    - a. Minimum Service Temperature: 0 degrees F (minus 18 degrees C).
    - b. Maximum Service Temperature: 150 degrees F (66 degrees C).
    - c. Moisture Vapor Permeability: 0.002 perm inch (0.0029 ng/(Pa s m)), maximum, when tested in accordance with ASTM E96/E96M.
    - d. Thickness: 10 mil, 0.010 inch (0.25 mm).
    - e. Connections: Brush on welding adhesive.
  - 2. Covering Adhesive Mastic: Compatible with insulation.
- B. Aluminum Jacket:
  - 1. Comply with ASTM B209/B209M, Temper H14, minimum thickness of 0.016 inch (0.41 mm) with factory-applied polyethylene and kraft paper moisture barrier on the inside surface.
  - 2. Thickness: 0.016 inch (0.40 mm) sheet.
  - 3. Type: Factory-applied, self-adhesive jacketing.
  - 4. Finish: Smooth.

5. Joining: Longitudinal slip joints and 2 inch (50 mm) laps.
  6. Fittings: 0.016 inch (0.40 mm) thick die-shaped fitting covers with factory-attached protective liner.
  7. Metal Jacket Bands: 3/8 inch (10 mm) wide; 0.015 inch (0.38 mm) thick aluminum.
- C. Reinforced Tape:
1. FSK tape suitable for sealing seams between insulation, insulated pipe bends, and fittings resulting in a tight, smooth surface without wrinkles.
  2. Comply with UL 723, ASTM E84.
  3. Moisture Vapor Permeability: 0.00 perm inch (0.00 ng/(Pa s m)), when tested in accordance with ASTM E96/E96M.
  4. Finish: Match insulation.
- D. Plain Foil Tape:
1. Aluminum foil with pressure-sensitive adhesive on paper release liner.
  2. Finish: Plain foil.

## **2.07 ENGINEERED WALL OUTLET SEALS AND REFRIGERANT PIPING INSULATION PROTECTION**

- A. Pipe Penetration Wall Seal: Seals HVAC piping wall penetrations with compression gasket wall mounted rigid plastic outlet cover.
1. Outlet Cover Color: Gray.
  2. Water Penetration: Comply with ASTM E331.
  3. Air Leakage: Comply with ASTM E283.
  4. Air Permeance: Comply with ASTM E2178.
- B. Insulation Protection System: Refrigerant piping insulation PVC protective cover.
1. PVC Insulation Cover Color: White with full-length velcro fastener.
  2. Weatherization and Ultraviolet Exposure Protection: Comply with ASTM G153.
  3. Water/Vapor Permeability: Comply with ASTM E96/E96M.
  4. Anti-Fungal and Anti-Microbial Resistance: Comply with ASTM G21.
  5. Flame Spread and Smoke Development Rating of 24/450: Comply with ASTM E84 or UL 723.
  6. Carbon Arc Light Exposure: Comply with ASTM G153.
  7. Tensile Strength After UV Exposure and Water Immersion: Comply with ASTM D412.
  8. Water Absorption of Plastics: Comply with ASTM D570.
  9. Adhesive free.

## **2.08 ACCESSORIES**

- A. General Requirements:
1. Provide required accessories in accordance with and subject to the recommendations of the insulation manufacturer.
  2. Furnish compatible materials which do not contribute to corrosion, soften, or otherwise attack surfaces to which applied, in either the wet or dry state.
  3. Comply with ASTM C795 requirements for materials to be used on stainless steel surfaces.
  4. Supply materials that are asbestos free.
- B. Corrosion Inhibitors:
1. Corrosion Control Gel:
    - a. Corrosion Protection: Comply with ASTM B117 and ASTM D610.

## **PART 3 EXECUTION**

### **3.01 EXAMINATION**

- A. Test piping for design pressure, liquid tightness, and continuity prior to applying insulation materials.
- B. Verify that surfaces are clean and dry, with foreign material removed.



### 3.02 INSTALLATION

- A. Install in accordance with manufacturer's instructions.
- B. Exposed Piping: Locate insulation and cover seams in least visible locations.
- C. Insulated Pipes Conveying Fluids Below Ambient Temperature:
  - 1. Insulate entire system, including fittings, valves, unions, flanges, strainers, flexible connections, pump bodies, and expansion joints.
- D. Glass Fiber Insulated Pipes Conveying Fluids Below Ambient Temperature:
  - 1. Provide vapor barrier jackets, factory-applied or field-applied; secure with self-sealing longitudinal laps and butt strips with pressure-sensitive adhesive. Secure with outward clinch expanding staples and vapor barrier mastic.
  - 2. Insulate fittings, joints, and valves with molded insulation of like material and thickness as adjacent pipe. Finish with glass cloth and vapor barrier adhesive or PVC fitting covers.
- E. For hot piping conveying fluids 140 degrees F (60 degrees C) or less, do not insulate flanges and unions at equipment, but bevel and seal ends of insulation.
- F. For hot piping conveying fluids over 140 degrees F (60 degrees C), insulate flanges and unions at equipment.
- G. Glass Fiber Insulated Pipes Conveying Fluids Above Ambient Temperature:
  - 1. Provide standard jackets, with or without vapor barrier, factory-applied, or field-applied. Secure with self-sealing longitudinal laps and butt strips with pressure-sensitive adhesive. Secure with outward clinch expanding staples.
  - 2. Insulate fittings, joints, and valves with insulation of like material and thickness as adjoining pipe. Finish with glass cloth and adhesive or PVC fitting covers.
- H. Inserts and Shields:
  - 1. Application: Piping 1-1/2 inches (40 mm) diameter or larger.
  - 2. Shields: Galvanized steel between pipe hangers or pipe hanger rolls and inserts.
  - 3. Insert location: Between support shield and piping and under the finish jacket.
  - 4. Insert Configuration: Minimum 6 inches (150 mm) long, of same thickness and contour as adjoining insulation; may be factory fabricated.
  - 5. Insert Material: Hydrous calcium silicate insulation or other heavy density insulating material suitable for the planned temperature range.
- I. Continue insulation through walls, sleeves, pipe hangers, and other pipe penetrations. Finish at supports, protrusions, and interruptions. At fire separations, see Section 078400.
- J. Pipe Exposed in Mechanical Equipment Rooms or Finished Spaces (less than 10 feet (3 meters) above finished floor): Finish with PVC jacket and fitting covers.
- K. Exterior Applications: Provide vapor barrier jacket. Insulate fittings, joints, and valves with insulation of like material and thickness as adjoining pipe, and finish with glass mesh reinforced vapor barrier cement. Cover with aluminum jacket with seams located on bottom side of horizontal piping. Provide two coats of UV resistant finish for flexible elastomeric cellular insulation without jacketing.

**END OF SECTION**

**SECTION 232300  
REFRIGERANT PIPING**

**PART 1 GENERAL**

**1.01 SECTION INCLUDES**

- A. Piping.
- B. Engineered wall seals and insulation protection.
- C. Exterior penetration accessories.

**1.02 SUBMITTALS**

- A. Product Data: Provide general assembly of specialties, including manufacturer's catalogue information. Provide manufacturer's catalog data including load capacity.

**1.03 DELIVERY, STORAGE, AND HANDLING**

- A. Deliver and store piping and specialties in shipping containers with labeling in place.
- B. Protect piping and specialties from entry of contaminating material by leaving end caps and plugs in place until installation.
- C. Dehydrate and charge components such as piping and receivers, seal prior to shipment, until connected into system.

**PART 2 PRODUCTS**

**2.01 SYSTEM DESCRIPTION**

- A. Where more than one piping system material is specified ensure system components are compatible and joined to ensure integrity of system is not jeopardized. Provide necessary joining fittings. Ensure flanges, union, and couplings for servicing are consistently provided.
- B. Provide pipe hangers and supports in accordance with ASME B31.5 unless indicated otherwise.

**2.02 REGULATORY REQUIREMENTS**

- A. Comply with ASME B31.9 for installation of piping system.
- B. Welding Materials and Procedures: Comply with ASME BPVC-IX and applicable state labor regulations.
- C. Welders Certification: In accordance with ASME BPVC-IX.
- D. Products Requiring Electrical Connection: Listed and classified by UL, as suitable for the purpose indicated.

**2.03 PIPING**

- A. Copper Tube: ASTM B280, H58 hard drawn or O60 soft annealed.
  - 1. Fittings: ASME B16.22 wrought copper.
  - 2. Joints: Braze, AWS A5.8M/A5.8 BCuP silver/phosphorus/copper alloy.
- B. Copper Tube to 7/8-inch (22 mm) OD: ASTM B88 (ASTM B88M), Type K (A), annealed.
  - 1. Fittings: ASME B16.26 cast copper.
  - 2. Joints: Flared.
- C. Pipe Supports and Anchors:
  - 1. Provide hangers and supports that comply with MSS SP-58.
    - a. If type of hanger or support for a particular situation is not indicated, select appropriate type using MSS SP-58 recommendations.

**2.04 ENGINEERED WALL SEALS AND INSULATION PROTECTION**

- A. Pipe Penetration Wall Seal: Seals HVAC piping wall penetrations with compression gasket wall mounted rigid plastic outlet cover.
  - 1. Outlet Cover Color: Gray.
  - 2. Water Penetration: Comply with ASTM E331.

3. Air Leakage: Comply with ASTM E283/E283M.
  4. Air Permeance: Comply with ASTM E2178.
- B. Insulation Protection System: Mechanical line insulation and PVC cover.
1. PVC Insulation Cover Color: White with full-length velcro fastener.
  2. Weatherization and Ultraviolet Exposure Protection: Comply with ASTM G153.
  3. Water/Vapor Permeability: Comply with ASTM E96/E96M.
  4. Anti-Fungal and Anti-Microbial Resistance: Comply with ASTM G21.
  5. Flame Spread and Smoke Development Rating of 25/450: Comply with ASTM E84.
  6. Adhesive free.

## **2.05 EXTERIOR PENETRATION ACCESSORIES**

- A. Sealing Systems for Roof Penetrations: Premanufactured components and accessories as required to preserve integrity of roofing system and maintain roof warranty; suitable for conduits and roofing system to be installed; designed to accommodate existing penetrations where applicable.

## **PART 3 EXECUTION**

### **3.01 PREPARATION**

- A. Ream pipe and tube ends. Remove burrs. Bevel plain-end ferrous pipe.
- B. Remove scale and dirt on inside and outside before assembly.
- C. Prepare piping connections to equipment with flanges or unions.

### **3.02 INSTALLATION**

- A. Install refrigeration specialties in accordance with manufacturer's instructions.
- B. Route piping in orderly manner, with plumbing parallel to building structure, and maintain gradient.
- C. Install piping to conserve building space and avoid interference with use of space.
- D. Group piping whenever practical at common elevations and locations. Slope piping one percent in direction of oil return.
- E. Install piping to allow for expansion and contraction without stressing pipe, joints, or connected equipment.
- F. Pipe Hangers and Supports:
  1. Install in accordance with ASME B31.5.
  2. Support horizontal piping as indicated.
  3. Install hangers to provide minimum 1/2 inch (13 mm) space between finished covering and adjacent work.
  4. Place hangers within 12 inches (300 mm) of each horizontal elbow.
  5. Support vertical piping at every other floor. Support riser piping independently of connected horizontal piping.
  6. Where several pipes can be installed in parallel and at same elevation, provide multiple or trapeze hangers.
  7. Provide copper plated hangers and supports for copper piping.
- G. Arrange piping to return oil to compressor. Provide traps and loops in piping, and provide double risers as required. Slope horizontal piping 0.40 percent in direction of flow.
- H. Provide clearance for installation of insulation and access to valves and fittings.
- I. Provide access to concealed valves and fittings.
- J. Flood piping system with nitrogen when brazing.
- K. Insulate piping and equipment.
- L. Follow ASHRAE Std 15 procedures for charging and purging of systems and for disposal of refrigerant.
- M. Fully charge completed system with refrigerant after testing.

### **3.03 FIELD QUALITY CONTROL**

- A. See Section 014000 - Quality Requirements, for additional requirements.
- B. Test refrigeration system in accordance with ASME B31.5.
- C. Pressure test system with dry nitrogen to 200 psi (1380 kPa). Perform final tests at 27 inches (92 kPa) vacuum and 200 psi (1380 kPa) using electronic leak detector. Test and repair piping until no leakage.

**END OF SECTION**

**SECTION 233100  
HVAC DUCTS AND CASINGS**

**PART 1 GENERAL**

**1.01 SECTION INCLUDES**

- A. Metal ducts.
- B. Flexible ducts.
- C. Air plenums and casings.

**1.02 SUBMITTALS**

- A. Product Data: Provide data for duct materials.

**1.03 FIELD CONDITIONS**

- A. Do not install duct sealants when temperatures are less than those recommended by sealant manufacturers.
- B. Maintain temperatures within acceptable range during and after installation of duct sealants.

**PART 2 PRODUCTS**

**2.01 GENERAL REQUIREMENTS**

- A. Provide UL Class 1 ductwork, fittings, hangers, supports, and appurtenances in accordance with NFPA 90A and SMACNA (DCS) guidelines unless stated otherwise.
- B. Provide metal duct unless otherwise indicated.
- C. Duct Fabrication Requirements:
  - 1. Duct and Fitting Fabrication and Support: SMACNA (DCS) including specifics for continuously welded round and oval duct fittings.
  - 2. Use reinforced and sealed sheet-metal materials at recommended gauges for indicated operating pressures or pressure class.
  - 3. Construct tees, bends, and elbows with radius of not less than 1-1/2 times width of duct on centerline. Where not possible and where rectangular elbows must be used, provide airfoil turning vanes of perforated metal with glass fiber insulation.
  - 4. Provide turning vanes of perforated metal with glass fiber insulation when acoustical lining is indicated.
  - 5. Increase duct sizes gradually, not exceeding 15 degrees divergence wherever possible; maximum 30 degrees divergence upstream of equipment and 45 degrees convergence downstream.
  - 6. Provide turning vanes of perforated metal with glass fiber insulation when an acoustical lining is required.
  - 7. Where ducts are connected to exterior wall louvers and duct outlet is smaller than louver frame, provide blank-out panels sealing louver area around duct. Use same material as duct, painted black on exterior side; seal to louver frame and duct.

**2.02 METAL DUCTS**

**2.03 METAL DUCTS**

- A. Material Requirements:
  - 1. Galvanized Steel: Hot-dipped galvanized steel sheet, ASTM A653/A653M FS Type B, with G60/Z180 coating.
- B. Round Metal Ducts:
  - 1. Round Single Wall Duct: Round lock seam duct with galvanized steel outer wall.
  - 2. Round Connection System: Interlocking duct connection system in accordance with SMACNA (DCS).
- C. Round Spiral Duct:
  - 1. Round spiral lock seam duct with galvanized steel outer wall.
- D. Connectors, Fittings, Sealants, and Miscellaneous:

1. Fittings: Manufacture with solid inner wall of perforated galvanized steel.
2. Transverse Duct Connection System: SMACNA "E" rated rigid class connection, interlocking angle and duct edge connection system with sealant, gasket, cleats, and corner clips in accordance with SMACNA (DCS).
3. Joint Sealers and Sealants: Non-hardening, water resistant, mildew and mold resistant.
  - a. Type: Heavy mastic or liquid used alone or with tape, suitable for joint configuration and compatible with substrates, and recommended by manufacturer for pressure class of ducts.
  - b. VOC Content: Not more than 250 g/L, excluding water.
  - c. Surface Burning Characteristics: Flame spread index of zero and smoke developed index of zero, when tested in accordance with ASTM E84.
  - d. For Use with Flexible Ducts: UL labeled.
4. Gasket Tape:
  - a. Provide butyl rubber gasket tape for a flexible seal between transfer duct connector (TDC), transverse duct flange (TDF), applied flange connections, and angle ring connections.
5. Hanger Rod: ASTM A36/A36M; steel, galvanized; threaded both ends, threaded one end, or continuously threaded.

#### **2.04 FLEXIBLE DUCTS**

- A. Flexible Ducts: UL 181, Class 1, polyethylene film, mechanically fastened and rolled using galvanized steel to form spiral helix.
  1. Insulation: R6 insulation with polyethylene vapor barrier film.
  2. Pressure Rating: 10 in-wc (2.50 kPa) positive and 5 in-wc (1.25 kPa) negative.
  3. Maximum Velocity: 5500 fpm (27.9 m/sec).
  4. Temperature Range: Minus 20 degrees F to 250 degrees F (Minus 28 degrees C to 121 degrees C).
- B. Acoustic Flexible Ducts: UL 181, Class 1, spunbond nylon, mechanically fastened and rolled using galvanized steel to form spiral helix.
  1. Insulation: Fiberglass insulation with metallic vapor barrier.
  2. Inner Core: Spunbonded, nonwoven inner core.
  3. Pressure Rating: 6 in-wc (1.5 kPa) positive and 5 in-wc (1.25 kPa) negative.
  4. Maximum Velocity: 4000 fpm (20.3 m/sec).
  5. Temperature Range: Minus 20 degrees F to 250 degrees F (Minus 28 degrees C to 121 degrees C).

#### **2.05 AIR PLENUMS AND CASINGS**

- A. Fabricate in accordance with SMACNA (DCS) for indicated operating pressures indicated.
- B. Minimum Fabrication Requirements:
  1. Fabricate acoustic plenum or casing with reinforcing turned inward.
  2. Provide 16-gauge, 0.059-inch (1.52 mm) sheet steel back facing and 22-gauge, 0.029-inch (0.76 mm) perforated sheet steel front facing with 3/32 inch (2.4 mm) diameter holes on 5/32 inch (4 mm) centers.
  3. Construct panels 3 inches (75 mm) thick, packed with 4.5 pcf (72 kg/cu m) minimum glass fiber insulation media, on inverted channel of 16-gauge, 0.059-inch (1.52 mm) sheet steel.
  4. Mount floor-mounted plenum or casings on 4-inch (100 mm) high concrete curbs. At floor, rivet panels on 8-inch (200 mm) centers to angles. Where floors are acoustically insulated, provide liner of galvanized 18-gauge, 0.052-inch (1.31 mm) expanded metal mesh supported at 12-inch (300 mm) centers, turned up 12 inches (300 mm) at sides with sheet metal shields.
- C. Access Doors:
  1. Install hinged access doors where indicated or required for access to equipment for cleaning and inspection.
  2. Reinforce door frames with steel angles tied to horizontal and vertical plenum supporting angles.

## **PART 3 EXECUTION**

### **3.01 INSTALLATION**

- A. Install, support, and seal ducts in accordance with SMACNA (DCS).
- B. Install products following the manufacturer's instructions.
- C. Comply with safety standards NFPA 90A and NFPA 90B.
- D. During construction, provide temporary closures of metal or taped polyethylene on open ductwork to prevent construction dust from entering the ductwork system.
- E. Increase duct sizes gradually, not exceeding 15 degrees divergence wherever possible; maximum 30 degrees divergence upstream of equipment and 45 degrees convergence downstream.
- F. Flexible Ducts: Connect to metal ducts with adhesive.
- G. Kitchen Range Hoods: Install when provided by Section 114000 then fit-out with respective ductwork and accessories to interconnect exhaust system.
- H. Duct sizes indicated are precise inside dimensions. For lined ducts, maintain sizes inside lining.
- I. Locate ducts with sufficient space around equipment to allow normal operating and maintenance activities.
- J. Use double nuts and lock washers on threaded rod supports.
- K. At exterior wall louvers, seal duct to louver frame and install blank-out panels.
- L. Louver Fit-out:
  - 1. Provide blank-out panels sealing available area of wall-mounted exterior-faced louver when connected ductwork is smaller than actual louver free area, and duct outlet is smaller than the louver frame.
  - 2. Use the same duct material painted black on the exterior side, then seal louver frame and duct.
- M. Plenums and Casings:
  - 1. Mount floor-mounted casings on 4 inch (100 mm) high concrete curbs.
  - 2. At floor, rivet panels on 8 inch (200 mm) centers to angles.
  - 3. Where floors are acoustically insulated, provide liner of galvanized 18-gauge, 0.052-inch (1.31 mm) expanded metal mesh supported at 12-inch (300 mm) centers, turned up 12 inches (300 mm) at sides with sheet metal shields.
- N. Fire Partitions: Provide firestopping sealing. See Section 078400.
- O. Duct Accessories, Terminal Units, Inlets, and Outlets: Interconnect as indicated in Section 233700.
- P. Duct Insulation: Provide duct insulation. See Section 230713.

**END OF SECTION**

**SECTION 233423  
HVAC POWER VENTILATORS**

**PART 1 GENERAL**

**1.01 SECTION INCLUDES**

- A. Ceiling exhaust fans.

**PART 2 PRODUCTS**

**2.01 POWER VENTILATORS - GENERAL**

- A. Static and Dynamically Balanced: Comply with AMCA 204.
- B. Performance Ratings: Comply with AMCA 210, bearing certified rating seal.
- C. Sound Ratings: Comply with AMCA 301, tested to AMCA 300, bearing certified sound ratings seal.
- D. Fabrication: Comply with AMCA 99.
- E. UL Compliance: UL 705, listed, labeled, designed, manufactured, and tested.
- F. Electrical Components: Listed and classified by Underwriters Laboratories Inc. as suitable for the purpose specified and indicated.

**2.02 CEILING EXHAUST FANS**

- A. Centrifugal Fan Unit: Direct driven with galvanized steel housing lined with acoustic insulation, resiliently mounted motor, gravity backdraft damper in discharge.
- B. Disconnect Switch: Cord and plug-in housing for thermal overload protected motor and wall mounted switch.
- C. Grille: Molded white plastic.

**PART 3 EXECUTION**

**3.01 INSTALLATION**

- A. Install in accordance with manufacturer's instructions.
- B. Provide backdraft dampers on outlet from cabinet and ceiling exhauster fans and as indicated.

**END OF SECTION**



**SECTION 233700  
AIR OUTLETS AND INLETS**

**PART 1 GENERAL**

**1.01 SECTION INCLUDES**

- A. Rectangular ceiling diffusers.
- B. Registers/grilles:
  - 1. Ceiling-mounted, egg crate exhaust and return register/grilles.
  - 2. Ceiling-mounted, exhaust and return register/grilles.
  - 3. Ceiling-mounted, supply register/grilles.
  - 4. Wall-mounted, supply register/grilles.
  - 5. Wall-mounted, exhaust and return register/grilles.
- C. Duct-mounted supply and return registers/louvers.
- D. Door grilles.
- E. Goosenecks.
- F. Gravity ventilators.

**1.02 SUBMITTALS**

- A. Product Data: Provide data for equipment required for this project. Review outlets and inlets as to size, finish, and type of mounting prior to submission. Submit schedule of outlets and inlets showing type, size, location, application, and noise level.

**PART 2 PRODUCTS**

**2.01 RECTANGULAR CEILING DIFFUSERS**

- A. Type: Provide square formed backpan stamped and multi-louvered ceiling diffusers constructed to maintain 360 degree discharge air pattern.
- B. Connections: Round.
- C. Frame: Provide surface mount and inverted T-bar type. In plaster ceilings, provide plaster frame and ceiling frame.
- D. Fabrication: Aluminum with baked enamel finish.
- E. Color: As indicated on drawings.

**2.02 DUCT-MOUNTED SUPPLY AND RETURN REGISTERS/LOUVERS**

- A. Type: Duct-mounted, rectangular register for round-spiral duct with adjustable pivot-ended blades, end caps, built-in volume damper, and dual cover flanges to lay flush on duct surface regardless of diameter. Performance to match manufacturer's catalog data.
- B. Material: 22 gauge, 0.0299 inch (0.76 mm).
  - 1. Provide crossing spiral fitting-body of matching duct diameter.
- C. Color: As indicated on drawings.

**2.03 CEILING SUPPLY REGISTERS/GRILLES**

- A. Type: Streamlined and individually adjustable curved blades to discharge air along face of grille, two-way deflection.
- B. Frame: 1-1/4 inch (32 mm) margin with countersunk screw mounting and gasket.
- C. Construction: Made of aluminum extrusions with factory enamel finish.
- D. Color: As indicated on drawings.
- E. Damper: Integral, gang-operated, opposed blade type with removable key operator, operable from face.

**2.04 CEILING EXHAUST AND RETURN REGISTERS/GRILLES**

- A. Type: Streamlined blades, 3/4 inch (19 mm) minimum depth, 3/4 inch (19 mm) maximum spacing, with blades set at 45 degrees, horizontal face.

- B. Frame: 1-1/4 inch (32 mm) margin with countersunk screw mounting.
- C. Fabrication: Aluminum extrusions, with factory baked enamel finish.
- D. Color: As indicated on the drawings.
- E. Damper: Integral, gang-operated, opposed blade type with removable key operator, operable from face where not individually connected to exhaust fans.

**2.05 CEILING EGG CRATE EXHAUST AND RETURN GRILLES**

- A. Type: Egg crate style face consisting of 1/2 by 1/2 by 1/2 inch (13 by 13 by 13 mm) grid core.
- B. Fabrication: Grid core consists of aluminum with mill aluminum finish.
- C. Color: To be selected by Architect from manufacturer's standard range.
- D. Frame: 1-1/4 inch (32 mm) margin with countersunk screw mounting.
- E. Frame: Channel lay-in frame for suspended grid ceilings.

**2.06 WALL SUPPLY REGISTERS/GRILLES**

- A. Type: Streamlined and individually adjustable blades, 3/4 inch (19 mm) minimum depth, 3/4 inch (19 mm) maximum spacing with spring or other device to set blades, vertical face, double deflection.
- B. Frame: 1-1/4 inch (32 mm) margin with countersunk screw mounting and gasket.
- C. Fabrication: Aluminum extrusions, with factory baked enamel finish.
- D. Damper: Integral, gang-operated opposed blade type with removable key operator, operable from face.

**2.07 WALL EXHAUST AND RETURN REGISTERS/GRILLES**

- A. Type: Streamlined blades, 3/4 inch (19 mm) minimum depth, 3/4 inch (19 mm) maximum spacing, with spring or other device to set blades, horizontal face.
- B. Frame: 1-1/4 inch (32 mm) margin with countersunk screw mounting.
- C. Fabrication: Aluminum extrusions, with factory baked enamel finish.
- D. Color: As indicated on the drawings.
- E. Damper: Integral, gang-operated, opposed blade type with removable key operator, operable from face.

**2.08 DOOR GRILLES**

- A. Type: V-shaped louvers of 20 gauge, 0.0359 inch (0.91 mm) thick steel, 1 inch (25 mm) deep on 1/2 inch (13 mm) centers.

**2.09 GOOSENECKS**

- A. Fabricate in accordance with of minimum 18 gauge, 0.0598 inch (1.21 mm) galvanized steel.

**2.10 GRAVITY VENTILATORS**

- A. Spun Aluminum Intake and Relief Gravity Ventilator:
  - 1. General:
    - a. Provide low silhouette configuration for intake and relief applications with natural gravity or negative pressure system.
    - b. Performance ratings and factory testing in accordance with AMCA 511 and AMCA 550.
    - c. Suitable for non-ducted applications.
    - d. Equipment to bear permanently affixed manufacturer's nameplate listing model and serial number.
  - 2. Hood:
    - a. Material: Aluminum.
    - b. Internal structure constructed of galvanized steel.
  - 3. Birdscreen:

- a. Fabricate in accordance with ASTM B221 (ASTM B221M).
  - b. Construction: 1/2 inch (12.7 mm) galvanized mesh.
  - c. Horizontally mounted across hood intake area.
4. Housing:
- a. Curb Cap:
    - 1) Construction: Aluminum.
    - 2) Integral deep spun inlet venturi with pre-punched mounting holes to ensure correct attachment to roof.
  - b. Windband:
    - 1) One piece spun aluminum construction with uniform, original material thickness throughout housing.
    - 2) Include integral rolled bead for strength.
5. Options/Accessories:
- a. Roof Curbs:
    - 1) Flat Roofs:
      - (a) Welded, straight side curb with flashing flange and wood nailer.
      - (b) Tabbed and riveted curb with 45 degree cant and wood nailer.
      - (c) Welded curb with 45 degree cant and wood nailer.
    - 2) Pitched Roofs: Welded, straight side curb with flashing flange and wood nailer.
    - 3) Material: Aluminum.
    - 4) Insulation Thickness: 1 inch (25.4 mm).
  - b. Curb Seal: Rubber seal between fan and roof curb.
  - c. Dampers:
    - 1) Type: Gravity.
    - 2) Factory designed to prevent outside air from entering back into building when fan is off.
    - 3) Balanced for minimal resistance to flow.
    - 4) Galvanized frames with pre-punched mounting holes.
  - d. Flashing Flange:
    - 1) Construction:
      - (a) Aluminum.
      - (b) Pre-punched holes for installation without a roof curb.

## **PART 3 EXECUTION**

### **3.01 INSTALLATION**

- A. Install in accordance with manufacturer's instructions.
- B. Comply with SMACNA (ASMM) for flashing/counter-flashing of roof penetrations and supports for roof curbs and roof mounted equipment.
- C. Check location of outlets and inlets and make necessary adjustments in position to comply with architectural features, symmetry, and lighting arrangement.
- D. Install diffusers to ductwork with air tight connection.
- E. Provide balancing dampers on duct take-off to diffusers and grilles and registers, despite whether dampers are specified as part of diffuser, or grille and register assembly.
- F. Paint ductwork visible behind air outlets and inlets matte black.

### **3.02 PROTECTION**

- A. Protect installed products until completion of project.
- B. Replace, repair, or touch-up damaged products before Substantial Completion.

### **END OF SECTION**

**SECTION 238126.13  
SMALL-CAPACITY SPLIT-SYSTEM AIR CONDITIONERS**

**PART 1 GENERAL**

**1.01 SECTION INCLUDES**

- A. Air-source heat pumps.
- B. Air cooled condensing units.
- C. Indoor air handling (fan and coil) units for ducted systems.
- D. Indoor air handling (fan and coil) units for ductless systems.
- E. Controls.

**1.02 SUBMITTALS**

- A. Product Data: Provide rated capacities, weights, accessories, electrical nameplate data, and wiring diagrams.

**PART 2 PRODUCTS**

**2.01 SYSTEM DESIGN**

- A. Split-System Heating and Cooling Units: Self-contained, packaged, matched factory-engineered and assembled, pre-wired indoor and outdoor units; UL listed.
  - 1. Heating and Cooling: Air-source electric heat pump located in outdoor unit with evaporator; auxiliary electric heat.
  - 2. Provide refrigerant lines internal to units and between indoor and outdoor units, factory cleaned, dried, pressurized and sealed, with insulated suction line.

**2.02 INDOOR AIR HANDLING UNITS FOR DUCTED SYSTEMS**

- A. Indoor Units: Self-contained, packaged, factory assembled, pre-wired unit consisting of cabinet, supply fan, heating and cooling element(s), controls, and accessories; wired for single power connection with control transformer.
  - 1. Air Flow Configuration: upflow or horizontal flow, as per plans.
  - 2. Cabinet: Steel with baked enamel finish, easily removed and secured access doors with safety interlock switches, glass fiber insulation with reflective liner.
- B. Supply Fan: Centrifugal type rubber mounted with direct drive motor.
- C. Air Filters: 1 inch (25 mm) thick glass fiber, disposable type arranged for easy replacement.
- D. Evaporator Coils: Copper tube aluminum fin assembly, galvanized or polymer drain pan sloped in all directions to drain, drain connection, refrigerant piping connections, restricted distributor or thermostatic expansion valve.
  - 1. Construction and Ratings: In accordance with AHRI 210/240 and UL 207.
  - 2. Manufacturers: System manufacturer.

**2.03 INDOOR AIR HANDLING UNITS FOR DUCTLESS SYSTEMS**

- A. Indoor Units: Self-contained, packaged, factory assembled, pre-wired unit consisting of cabinet, supply fan, evaporator coil, and controls; wired for single power connection with control transformer.
  - 1. Location: High-wall.
  - 2. Fan: Line-flow fan direct driven by a single motor.
  - 3. Filter return air with washable, antioxidant pre-filter and a pleated anti-allergy enzyme filter.
- B. Evaporator Coils: Copper tube aluminum fin assembly, galvanized or polymer drain pan sloped in all directions to drain, drain connection, refrigerant piping connections, restricted distributor or thermostatic expansion valve.
  - 1. Construction and Ratings: In accordance with AHRI 210/240 and UL 207.
  - 2. Manufacturer: System manufacturer.

## **2.04 OUTDOOR UNITS**

- A. Outdoor Units: Self-contained, packaged, pre-wired unit consisting of cabinet, with compressor and condenser.
  - 1. Comply with AHRI 210/240.
  - 2. Refrigerant: R-410A.
  - 3. Cabinet: Galvanized steel with baked enamel finish, easily removed and secured access doors with safety interlock switches, glass fiber insulation with reflective liner.
  - 4. Construction and Ratings: In accordance with AHRI 210/240 with testing in accordance with ASHRAE Std 23 and UL 207.
- B. Air Cooled Condenser: Aluminum fin and copper tube coil, AHRI 520 with direct drive axial propeller fan resiliently mounted, galvanized fan guard.
  - 1. Condenser Fans: Direct-drive propeller type.
  - 2. Condenser Fan Motor: Enclosed, 1-phase type, permanently lubricated.
- C. Coil: Air-cooled, aluminum fins bonded to copper tubes.
- D. Operating Controls:
  - 1. Control by room thermostat to maintain room temperature setting.
  - 2. Low Ambient Kit: Provide refrigerant pressure switch to cycle condenser fan on when condenser refrigerant pressure is above 285 psig (1965 kPa) and off when pressure drops below 140 psig (965 kPa) for operation to 0 degrees F (-18 degrees C).

## **2.05 ACCESSORY EQUIPMENT**

- A. Room Thermostat: Wall-mounted, electric solid state microcomputer based room thermostat with remote sensor to maintain temperature setting; low-voltage; with following features:
  - 1. Automatic switching from heating to cooling.
  - 2. Preferential rate control to minimize overshoot and deviation from setpoint.
  - 3. Set-up for four separate temperatures per day.
  - 4. Instant override of setpoint for continuous or timed period from one hour to 31 days.
  - 5. Short cycle protection.
  - 6. Programming based on every day of the week.
  - 7. Selection features including degree F or degree C display, 12 or 24 hour clock, keyboard disable, remote sensor, fan on-auto.
  - 8. Battery replacement without program loss.

## **PART 3 EXECUTION**

### **3.01 EXAMINATION**

- A. Verify that substrates are ready for installation of units and openings are as indicated on shop drawings.
- B. Verify that proper power supply is available and in correct location.

### **3.02 INSTALLATION**

- A. Install in accordance with manufacturer's instructions and requirements of local authorities having jurisdiction.
- B. Install in accordance with NFPA 90A and NFPA 90B.
- C. Install refrigeration systems in accordance with ASHRAE Std 15.

**END OF SECTION**

**SECTION 238200  
CONVECTION HEATING AND COOLING UNITS**

**PART 1 GENERAL**

**1.01 SECTION INCLUDES**

- A. Electric unit heaters.
- B. Electric cabinet unit heaters.

**1.02 SUBMITTALS**

- A. Product Data: Provide typical catalog of information including arrangements.

**1.03 QUALITY ASSURANCE**

- A. Products Requiring Electrical Connection: Listed and classified by Underwriters Laboratories Inc. as suitable for the purpose specified and indicated.

**PART 2 PRODUCTS**

**2.01 ELECTRIC UNIT HEATERS**

- A. Provide products listed, classified, and labeled by Underwriters Laboratories Inc. (UL), Intertek (ETL), or testing firm acceptable to authority having jurisdiction as suitable for purpose indicated.
- B. Heating Element Assembly:
  - 1. Thermal safety cut-out within electric terminal box with automatically reset switch located near electric terminal box.
- C. Housing:
  - 1. Suitable for ceiling or high altitude mount using provided hardware appendages.
- D. Air Inlets and Outlets:
  - 1. Inlets: Provide stamped louvers or protective grilles with fan blade guard.
  - 2. Outlets: Provide diffuser cones, directional louvers, or radial diffusers.
- E. Fan: Factory balanced, direct drive, axial type with fan guard.
- F. Motor: Totally enclosed, thermally protected, and provided with permanently lubricated bearings.
- G. Controls:
  - 1. Built-in thermostat.

**2.02 ELECTRIC CABINET UNIT HEATERS**

- A. Provide products listed, classified, and labeled by Underwriters Laboratories Inc. (UL), Intertek (ETL), or testing firm acceptable to authority having jurisdiction as suitable for purpose indicated.
- B. Heating Elements: Provide open-wire, finned tubular, or resistance wire enclosed in steel sheath.
- C. Cabinet:
  - 1. Minimum 18 gauge, 0.0478 inch (1.21 mm) thick steel front panel with exposed corners and edges rounded, easily removed panels, glass fiber insulation and integral air outlet, and inlet grilles.
  - 2. Provide required hardware accessories for ceiling, duct, recessed, semi-recessed, surface, or wall mounting.
- D. Finish:
  - 1. Factory applied, painted finish.
  - 2. Color: Factory standard color.
- E. Controls:
  - 1. Built-in thermostat.

- F. Filter: Easily removed, 1 inch (25 mm) thick glass fiber throw-away type, located to filter air before coil.

### **PART 3 EXECUTION**

#### **3.01 EXAMINATION**

- A. Verify that surfaces are suitable for installation.

#### **3.02 INSTALLATION**

- A. Install in accordance with manufacturer's recommendations.
- B. Install equipment exposed to finished areas after walls and ceilings are finished and painted.
- C. Do not damage equipment or finishes.
- D. Unit Heaters:
  - 1. Hang from building structure, with pipe hangers anchored to building, not from piping or electrical conduit.
  - 2. Mount as high as possible to maintain greatest headroom unless otherwise indicated.
- E. Cabinet Unit Heaters:
  - 1. Install as indicated.
  - 2. Coordinate to ensure correct recess size for recessed units.

#### **3.03 CLEANING**

- A. After construction and painting is completed, clean exposed surfaces of units.
- B. Vacuum clean coils and inside of units.
- C. Touch-up marred or scratched surfaces of factory-finished cabinets using finish materials furnished by the manufacturer.
- D. Install new filters.

#### **3.04 PROTECTION**

- A. Provide finished cabinet units with protective covers during the balance of construction.

**END OF SECTION**

**SECTION 260519**  
**LOW-VOLTAGE ELECTRICAL POWER CONDUCTORS AND CABLES**

**PART 1 GENERAL**

**1.01 SECTION INCLUDES**

- A. Single conductor building wire.
- B. Nonmetallic-sheathed cable.
- C. Service entrance cable.
- D. Wiring connectors.
- E. Electrical tape.
- F. Oxide inhibiting compound.
- G. Wire pulling lubricant.
- H. Cable ties.

**1.02 RELATED REQUIREMENTS**

- A. Section 078400 - Firestopping.
- B. Section 260553 - Identification for Electrical Systems: Identification products and requirements.
- C. Section 284600 - Fire Detection and Alarm: Fire alarm system conductors and cables.

**1.03 REFERENCE STANDARDS**

- A. ASTM B3 - Standard Specification for Soft or Annealed Copper Wire; 2013 (Reapproved 2018).
- B. ASTM B8 - Standard Specification for Concentric-Lay-Stranded Copper Conductors, Hard, Medium-Hard, or Soft; 2011 (Reapproved 2017).
- C. ASTM B33 - Standard Specification for Tin-Coated Soft or Annealed Copper Wire for Electrical Purposes; 2010, with Editorial Revision (2020).
- D. ASTM B787/B787M - Standard Specification for 19 Wire Combination Unilay-Stranded Copper Conductors for Subsequent Insulation; 2004 (Reapproved 2020).
- E. ASTM D3005 - Standard Specification for Low-Temperature Resistant Vinyl Chloride Plastic Pressure-Sensitive Electrical Insulating Tape; 2017.
- F. NECA 1 - Standard for Good Workmanship in Electrical Construction; 2015.
- G. NECA 104 - Standard for Installing Aluminum Building Wire and Cable; 2012.
- H. NECA 121 - Standard for Installing Nonmetallic-Sheathed Cable (Type NM-B) and Underground Feeder and Branch-Circuit Cable (Type UF); 2007.
- I. NEMA WC 70 - Power Cables Rated 2000 Volts or Less for the Distribution of Electrical Energy; 2021.
- J. NETA ATS - Standard For Acceptance Testing Specifications For Electrical Power Equipment And Systems; 2021.
- K. NFPA 70 - National Electrical Code; Most Recent Edition Adopted by Authority Having Jurisdiction, Including All Applicable Amendments and Supplements.
- L. UL 44 - Thermoset-Insulated Wires and Cables; Current Edition, Including All Revisions.
- M. UL 83 - Thermoplastic-Insulated Wires and Cables; Current Edition, Including All Revisions.
- N. UL 267 - Outline of Investigation for Wire-Pulling Compounds; Current Edition, Including All Revisions.
- O. UL 486A-486B - Wire Connectors; Current Edition, Including All Revisions.
- P. UL 486C - Splicing Wire Connectors; Current Edition, Including All Revisions.
- Q. UL 486D - Sealed Wire Connector Systems; Current Edition, Including All Revisions.



- R. UL 510 - Polyvinyl Chloride, Polyethylene, and Rubber Insulating Tape; Current Edition, Including All Revisions.
- S. UL 719 - Nonmetallic-Sheathed Cables; Current Edition, Including All Revisions.

#### **1.04 ADMINISTRATIVE REQUIREMENTS**

- A. Coordination:
  - 1. Coordinate sizes of raceways, boxes, and equipment enclosures installed under other sections with the actual conductors to be installed, including adjustments for conductor sizes increased for voltage drop.
  - 2. Coordinate with electrical equipment installed under other sections to provide terminations suitable for use with the conductors to be installed.
  - 3. Notify Architect of any conflicts with or deviations from Contract Documents. Obtain direction before proceeding with work.

#### **1.05 SUBMITTALS**

- A. See Section 013000 - Administrative Requirements, for submittal procedures.
- B. Product Data: Provide manufacturer's standard catalog pages and data sheets for conductors and cables, including detailed information on materials, construction, ratings, listings, and available sizes, configurations, and stranding.

#### **1.06 QUALITY ASSURANCE**

- A. Comply with requirements of NFPA 70.

#### **1.07 DELIVERY, STORAGE, AND HANDLING**

- A. Receive, inspect, handle, and store conductors and cables in accordance with manufacturer's instructions.

#### **1.08 FIELD CONDITIONS**

- A. Do not install or otherwise handle thermoplastic-insulated conductors at temperatures lower than 14 degrees F (-10 degrees C), unless otherwise permitted by manufacturer's instructions. When installation below this temperature is unavoidable, notify Architect and obtain direction before proceeding with work.

### **PART 2 PRODUCTS**

#### **2.01 CONDUCTOR AND CABLE APPLICATIONS**

- A. Do not use conductors and cables for applications other than as permitted by NFPA 70 and product listing.
- B. Provide single conductor building wire installed in suitable raceway unless otherwise indicated, permitted, or required. Use SER cable for panel feeders. SER cable does not need to be in raceway.
- C. Nonmetallic-sheathed cable is permitted only as follows:
  - 1. Where not otherwise restricted, may be used:
    - a. For branch circuit wiring in dry locations within multifamily dwellings permitted to be of Types III, IV, and V construction.
- D. Service entrance cable is permitted only as follows:
  - 1. In addition to other applicable restrictions, may not be used:
    - a. Where exposed to damage.

#### **2.02 CONDUCTOR AND CABLE GENERAL REQUIREMENTS**

- A. Provide products that comply with requirements of NFPA 70.
- B. Provide products listed, classified, and labeled as suitable for the purpose intended.
- C. Unless specifically indicated to be excluded, provide all required conduit, boxes, wiring, connectors, etc. as required for a complete operating system.
- D. Comply with NEMA WC 70.

- E. Thermoplastic-Insulated Conductors and Cables: Listed and labeled as complying with UL 83.
- F. Thermoset-Insulated Conductors and Cables: Listed and labeled as complying with UL 44.
- G. Conductor Material:
  - 1. Provide copper conductors only. Aluminum conductors are not acceptable for this project. Conductor sizes indicated are based on copper.
  - 2. Copper Conductors: Soft drawn annealed, 98 percent conductivity, uncoated copper conductors complying with ASTM B3, ASTM B8, or ASTM B787/B787M unless otherwise indicated.
  - 3. Tinned Copper Conductors: Comply with ASTM B33.
- H. Conductor Color Coding:
  - 1. Color code conductors as indicated unless otherwise required by the authority having jurisdiction. Maintain consistent color coding throughout project.
  - 2. Color Coding Method: Integrally colored insulation.
  - 3. Color Code:
    - a. 208Y/120 V, 3 Phase, 4 Wire System:
      - 1) Phase A: Black.
      - 2) Phase B: Red.
      - 3) Phase C: Blue.
      - 4) Neutral/Grounded: White.
    - b. Equipment Ground, All Systems: Green.

### **2.03 SINGLE CONDUCTOR BUILDING WIRE**

- A. Description: Single conductor insulated wire.
- B. Conductor Stranding:
  - 1. Feeders and Branch Circuits:
    - a. Size 10 AWG and Smaller: Solid.
    - b. Size 8 AWG and Larger: Stranded.
- C. Insulation Voltage Rating: 600 V.
- D. Insulation:
  - 1. Copper Building Wire: Type THHN/THWN or THHN/THWN-2, except as indicated below.

### **2.04 NONMETALLIC-SHEATHED CABLE**

- A. Description: NFPA 70, Type NM multiple-conductor cable listed and labeled as complying with UL 719, Type NM-B.
- B. Conductor Stranding:
  - 1. Size 10 AWG and Smaller: Solid.
  - 2. Size 8 AWG and Larger: Stranded.
- C. Insulation Voltage Rating: 600 V.

### **2.05 SERVICE ENTRANCE CABLE**

- A. Conductor Stranding: Stranded.
- B. Insulation Voltage Rating: 600 V.

### **2.06 WIRING CONNECTORS**

- A. Description: Wiring connectors appropriate for the application, suitable for use with the conductors to be connected, and listed as complying with UL 486A-486B or UL 486C as applicable.
- B. Wiring Connectors for Terminations:
  - 1. Aluminum Conductors: Use compression connectors for all connections.
  - 2. Stranded Conductors Size 10 AWG and Smaller: Use crimped terminals for connections to terminal screws.

- C. Do not use insulation-piercing or insulation-displacement connectors designed for use with conductors without stripping insulation.
- D. Do not use push-in wire connectors as a substitute for twist-on insulated spring connectors.
- E. Twist-on Insulated Spring Connectors: Rated 600 V, 221 degrees F (105 degrees C) for standard applications and 302 degrees F (150 degrees C) for high temperature applications; pre-filled with sealant and listed as complying with UL 486D for damp and wet locations.
- F. Compression Connectors: Provide circumferential type or hex type crimp configuration.
- G. Crimped Terminals: Nylon-insulated, with insulation grip and terminal configuration suitable for connection to be made.

## **2.07 ACCESSORIES**

- A. Electrical Tape:
  - 1. Vinyl Color Coding Electrical Tape: Integrally colored to match color code indicated; listed as complying with UL 510; minimum thickness of 7 mil (0.18 mm); resistant to abrasion, corrosion, and sunlight; suitable for continuous temperature environment up to 221 degrees F (105 degrees C).
  - 2. Vinyl Insulating Electrical Tape: Complying with ASTM D3005 and listed as complying with UL 510; minimum thickness of 7 mil (0.18 mm); resistant to abrasion, corrosion, and sunlight; conformable for application down to 0 degrees F (-18 degrees C) and suitable for continuous temperature environment up to 221 degrees F (105 degrees C).
- B. Oxide Inhibiting Compound: Listed; suitable for use with the conductors or cables to be installed.
- C. Wire Pulling Lubricant:
  - 1. Listed and labeled as complying with UL 267.
  - 2. Suitable for use with conductors/cables and associated insulation/jackets to be installed.
  - 3. Suitable for use at installation temperature.
- D. Cable Ties: Material and tensile strength rating suitable for application.

## **PART 3 EXECUTION**

### **3.01 EXAMINATION**

- A. Verify that interior of building has been protected from weather.
- B. Verify that work likely to damage wire and cable has been completed.
- C. Verify that raceways, boxes, and equipment enclosures are installed and are properly sized to accommodate conductors and cables in accordance with NFPA 70.
- D. Verify that field measurements are as indicated.
- E. Verify that conditions are satisfactory for installation prior to starting work.

### **3.02 PREPARATION**

- A. Clean raceways thoroughly to remove foreign materials before installing conductors and cables.

### **3.03 INSTALLATION**

- A. Circuiting Requirements:
  - 1. Unless dimensioned, circuit routing indicated is diagrammatic.
  - 2. When circuit destination is indicated without specific routing, determine exact routing required.
  - 3. Arrange circuiting to minimize splices.
  - 4. Common Neutrals: Unless otherwise indicated, sharing of neutral/grounded conductors among up to three single phase branch circuits of different phases installed in the same raceway is not permitted. Provide dedicated neutral/grounded conductor for each individual branch circuit.
- B. Install products in accordance with manufacturer's instructions.

- C. Perform work in accordance with NECA 1 (general workmanship).
- D. Install aluminum conductors in accordance with NECA 104.
- E. Install nonmetallic-sheathed cable (Type NM-B) in accordance with NECA 121.
- F. Installation in Raceway:
  - 1. Tape ends of conductors and cables to prevent infiltration of moisture and other contaminants.
  - 2. Pull all conductors and cables together into raceway at same time.
  - 3. Do not damage conductors and cables or exceed manufacturer's recommended maximum pulling tension and sidewall pressure.
  - 4. Use suitable wire pulling lubricant where necessary, except when lubricant is not recommended by the manufacturer.
- G. Paralleled Conductors: Install conductors of the same length and terminate in the same manner.
- H. Secure and support conductors and cables in accordance with NFPA 70 using suitable supports and methods approved by the authority having jurisdiction. Provide independent support from building structure. Do not provide support from raceways, piping, ductwork, or other systems.
- I. Terminate cables using suitable fittings.
- J. Install conductors with a minimum of 12 inches (300 mm) of slack at each outlet.
- K. Neatly train and bundle conductors inside boxes, wireways, panelboards and other equipment enclosures.
- L. Group or otherwise identify neutral/grounded conductors with associated ungrounded conductors inside enclosures in accordance with NFPA 70.
- M. Make wiring connections using specified wiring connectors.
  - 1. Make splices and taps only in accessible boxes. Do not pull splices into raceways or make splices in conduit bodies or wiring gutters.
  - 2. Remove appropriate amount of conductor insulation for making connections without cutting, nicking or damaging conductors.
  - 3. Do not remove conductor strands to facilitate insertion into connector.
  - 4. Clean contact surfaces on conductors and connectors to suitable remove corrosion, oxides, and other contaminants. Do not use wire brush on plated connector surfaces.
  - 5. Compression Connectors: Secure connections using manufacturer's recommended tools and dies.
- N. Insulate splices and taps that are made with uninsulated connectors using methods suitable for the application, with insulation and mechanical strength at least equivalent to unspliced conductors.
- O. Insulate ends of spare conductors using vinyl insulating electrical tape.
- P. Install firestopping to preserve fire resistance rating of partitions and other elements, using materials and methods specified in Section 078400.
- Q. Unless specifically indicated to be excluded, provide final connections to all equipment and devices, including those furnished by others, as required for a complete operating system.

### **3.04 FIELD QUALITY CONTROL**

- A. See Section 014000 - Quality Requirements, for additional requirements.
- B. Inspect and test in accordance with NETA ATS, except Section 4.
- C. Perform inspections and tests listed in NETA ATS, Section 7.3.2. The insulation resistance test is required for all conductors. The resistance test for parallel conductors listed as optional is not required.
- D. Correct deficiencies and replace damaged or defective conductors and cables.

**END OF SECTION**

**SECTION 260526  
GROUNDING AND BONDING FOR ELECTRICAL SYSTEMS**

**PART 1 GENERAL**

**1.01 SECTION INCLUDES**

- A. Grounding and bonding requirements.
- B. Conductors for grounding and bonding.
- C. Connectors for grounding and bonding.
- D. Ground rod electrodes.

**1.02 RELATED REQUIREMENTS**

- A. Section 260519 - Low-Voltage Electrical Power Conductors and Cables: Additional requirements for conductors for grounding and bonding, including conductor color coding.
- B. Section 260553 - Identification for Electrical Systems: Identification products and requirements.
- C. Section 265600 - Exterior Lighting: Additional grounding and bonding requirements for pole-mounted luminaires.
- D. Section 337900 - Site Grounding.

**1.03 REFERENCE STANDARDS**

- A. NECA 1 - Standard for Good Workmanship in Electrical Construction; 2015.
- B. NEMA GR 1 - Grounding Rod Electrodes and Grounding Rod Electrode Couplings; 2022.
- C. NETA ATS - Standard For Acceptance Testing Specifications For Electrical Power Equipment And Systems; 2021.
- D. NFPA 70 - National Electrical Code; Most Recent Edition Adopted by Authority Having Jurisdiction, Including All Applicable Amendments and Supplements.
- E. UL 467 - Grounding and Bonding Equipment; Current Edition, Including All Revisions.

**1.04 ADMINISTRATIVE REQUIREMENTS**

- A. Coordination:
  - 1. Verify exact locations of underground metal water service pipe entrances to building.
  - 2. Coordinate the work with other trades to provide steel reinforcement complying with specified requirements for concrete-encased electrode.
  - 3. Notify Architect of any conflicts with or deviations from Contract Documents. Obtain direction before proceeding with work.
- B. Sequencing:
  - 1. Do not install ground rod electrodes until final backfill and compaction is complete.

**1.05 SUBMITTALS**

- A. See Section 013000 - Administrative Requirements for submittals procedures.
- B. Product Data: Provide manufacturer's standard catalog pages and data sheets for grounding and bonding system components.

**1.06 QUALITY ASSURANCE**

- A. Comply with requirements of NFPA 70.

**1.07 DELIVERY, STORAGE, AND HANDLING**

- A. Receive, inspect, handle, and store products in accordance with manufacturer's instructions.

**PART 2 PRODUCTS**

**2.01 GROUNDING AND BONDING REQUIREMENTS**

- A. Do not use products for applications other than as permitted by NFPA 70 and product listing.
- B. Unless specifically indicated to be excluded, provide all required components, conductors, connectors, conduit, boxes, fittings, supports, accessories, etc. as necessary for a complete

grounding and bonding system.

- C. Where conductor size is not indicated, size to comply with NFPA 70 but not less than applicable minimum size requirements specified.
- D. Service-Supplied System Grounding:
  - 1. For each service disconnect, provide grounding electrode conductor to connect neutral (grounded) service conductor to grounding electrode system. Unless otherwise indicated, make connection at neutral (grounded) bus in service disconnect enclosure.
  - 2. For each service disconnect, provide main bonding jumper to connect neutral (grounded) bus to equipment ground bus where not factory-installed. Do not make any other connections between neutral (grounded) conductors and ground on load side of service disconnect.
- E. Bonding and Equipment Grounding:
  - 1. Provide bonding for equipment grounding conductors, equipment ground busses, metallic equipment enclosures, metallic raceways and boxes, device grounding terminals, and other normally non-current-carrying conductive materials enclosing electrical conductors/equipment or likely to become energized as indicated and in accordance with NFPA 70.
  - 2. Provide insulated equipment grounding conductor in each feeder and branch circuit raceway. Do not use raceways as sole equipment grounding conductor.
  - 3. Where circuit conductor sizes are increased for voltage drop, increase size of equipment grounding conductor proportionally in accordance with NFPA 70.
  - 4. Unless otherwise indicated, connect wiring device grounding terminal to branch circuit equipment grounding conductor and to outlet box with bonding jumper.
  - 5. Terminate branch circuit equipment grounding conductors on solidly bonded equipment ground bus only. Do not terminate on neutral (grounded) or isolated/insulated ground bus.
  - 6. Provide bonding jumper across expansion or expansion/deflection fittings provided to accommodate conduit movement.
- F. Communications Systems Grounding and Bonding:
  - 1. Provide intersystem bonding termination at service equipment or metering equipment enclosure and at disconnecting means for any additional buildings or structures in accordance with NFPA 70.
- G. Pole-Mounted Luminaires: Also comply with Section 265600.

## **2.02 GROUNDING AND BONDING COMPONENTS**

- A. General Requirements:
  - 1. Provide products listed, classified, and labeled as suitable for the purpose intended.
  - 2. Provide products listed and labeled as complying with UL 467 where applicable.
- B. Conductors for Grounding and Bonding, in Addition to Requirements of Section 260526:
  - 1. Use insulated copper conductors unless otherwise indicated.
    - a. Exceptions:
      - 1) Use bare copper conductors where installed underground in direct contact with earth.
      - 2) Use bare copper conductors where directly encased in concrete (not in raceway).
- C. Connectors for Grounding and Bonding:
  - 1. Description: Connectors appropriate for the application and suitable for the conductors and items to be connected; listed and labeled as complying with UL 467.
  - 2. Unless otherwise indicated, use exothermic welded connections for underground, concealed and other inaccessible connections.
  - 3. Unless otherwise indicated, use mechanical connectors, compression connectors, or exothermic welded connections for accessible connections.
- D. Ground Rod Electrodes:
  - 1. Comply with NEMA GR 1.

2. Material: Copper-bonded (copper-clad) steel.
3. Size: 3/4 inch (19 mm) diameter by 10 feet (3.0 m) length, unless otherwise indicated.

### **PART 3 EXECUTION**

#### **3.01 EXAMINATION**

- A. Verify that work likely to damage grounding and bonding system components has been completed.
- B. Verify that field measurements are as indicated.
- C. Verify that conditions are satisfactory for installation prior to starting work.

#### **3.02 INSTALLATION**

- A. Install products in accordance with manufacturer's instructions.
- B. Perform work in accordance with NECA 1 (general workmanship).
- C. Ground Rod Electrodes: Unless otherwise indicated, install ground rod electrodes vertically. Where encountered rock prohibits vertical installation, install at 45 degree angle or bury horizontally in trench at least 30 inches (750 mm) deep in accordance with NFPA 70 or provide ground plates.
- D. Make grounding and bonding connections using specified connectors.
  1. Remove appropriate amount of conductor insulation for making connections without cutting, nicking or damaging conductors. Do not remove conductor strands to facilitate insertion into connector.
  2. Remove nonconductive paint, enamel, or similar coating at threads, contact points, and contact surfaces.
  3. Exothermic Welds: Make connections using molds and weld material suitable for the items to be connected in accordance with manufacturer's recommendations.
  4. Mechanical Connectors: Secure connections according to manufacturer's recommended torque settings.
  5. Compression Connectors: Secure connections using manufacturer's recommended tools and dies.
- E. Identify grounding and bonding system components in accordance with Section 260553.

#### **3.03 FIELD QUALITY CONTROL**

- A. See Section 014000 - Quality Requirements, for additional requirements.
- B. Inspect and test in accordance with NETA ATS except Section 4.
- C. Perform inspections and tests listed in NETA ATS, Section 7.13.
- D. Perform ground electrode resistance tests under normally dry conditions. Precipitation within the previous 48 hours does not constitute normally dry conditions.
- E. Investigate and correct deficiencies where measured ground resistances do not comply with specified requirements.

**END OF SECTION**

**SECTION 260529  
HANGERS AND SUPPORTS FOR ELECTRICAL SYSTEMS**

**PART 1 GENERAL**

**1.01 SECTION INCLUDES**

- A. Support and attachment requirements and components for equipment, conduit, cable, boxes, and other electrical work.

**1.02 RELATED REQUIREMENTS**

- A. Section 033000 - Cast-in-Place Concrete: Concrete equipment pads.
- B. Section 260533.13 - Conduit for Electrical Systems: Additional support and attachment requirements for conduits.
- C. Section 260533.16 - Boxes for Electrical Systems: Additional support and attachment requirements for boxes.
- D. Section 265100 - Interior Lighting: Additional support and attachment requirements for interior luminaires.
- E. Section 265600 - Exterior Lighting: Additional support and attachment requirements for exterior luminaires.

**1.03 REFERENCE STANDARDS**

- A. ASTM A123/A123M - Standard Specification for Zinc (Hot-Dip Galvanized) Coatings on Iron and Steel Products; 2017.
- B. ASTM A153/A153M - Standard Specification for Zinc Coating (Hot-Dip) on Iron and Steel Hardware; 2023.
- C. ASTM B633 - Standard Specification for Electrodeposited Coatings of Zinc on Iron and Steel; 2023.
- D. MFMA-4 - Metal Framing Standards Publication; 2004.
- E. NECA 1 - Standard for Good Workmanship in Electrical Construction; 2015.
- F. NFPA 70 - National Electrical Code; Most Recent Edition Adopted by Authority Having Jurisdiction, Including All Applicable Amendments and Supplements.

**1.04 ADMINISTRATIVE REQUIREMENTS**

- A. Coordination:
  - 1. Coordinate sizes and arrangement of supports and bases with actual equipment and components to be installed.
  - 2. Coordinate work to provide additional framing and materials required for installation.
  - 3. Coordinate compatibility of support and attachment components with mounting surfaces at installed locations.
  - 4. Coordinate arrangement of supports with ductwork, piping, equipment and other potential conflicts.
  - 5. Notify Architect of conflicts with or deviations from Contract Documents. Obtain direction before proceeding with work.
- B. Sequencing:
  - 1. Do not install products on or provide attachment to concrete surfaces until concrete has cured; see Section 033000.

**1.05 QUALITY ASSURANCE**

- A. Product Listing Organization Qualifications: Organization recognized by OSHA as Nationally Recognized Testing Laboratory (NRTL) and acceptable to authorities having jurisdiction.

**1.06 DELIVERY, STORAGE, AND HANDLING**

- A. Receive, inspect, handle, and store products in accordance with manufacturer's instructions.



## **PART 2 PRODUCTS**

### **2.01 SUPPORT AND ATTACHMENT COMPONENTS**

- A. General Requirements:
  - 1. Comply with the following. Where requirements differ, comply with most stringent.
    - a. NFPA 70.
    - b. Requirements of authorities having jurisdiction.
  - 2. Provide required hangers, supports, anchors, fasteners, fittings, accessories, and hardware as necessary for complete installation of electrical work.
  - 3. Provide products listed, classified, and labeled as suitable for purpose intended, where applicable.
  - 4. Where support and attachment component types and sizes are not indicated, select in accordance with manufacturer's application criteria as required for load to be supported with minimum safety factor of \_\_\_\_\_. Include consideration for vibration, equipment operation, and shock loads where applicable.
  - 5. Do not use products for applications other than as permitted by NFPA 70 and product listing.
  - 6. Steel Components: Use corrosion-resistant materials suitable for environment where installed.
    - a. Zinc-Plated Steel: Electroplated in accordance with ASTM B633.
    - b. Galvanized Steel: Hot-dip galvanized after fabrication in accordance with ASTM A123/A123M or ASTM A153/A153M.
- B. Conduit and Cable Supports: Straps and clamps suitable for conduit or cable to be supported.
  - 1. Conduit Straps: One-hole or two-hole type; steel or malleable iron.
  - 2. Conduit Clamps: Bolted type unless otherwise indicated.
- C. Outlet Box Supports: Hangers and brackets suitable for boxes to be supported.
- D. Metal Channel/Strut Framing Systems:
  - 1. Description: Factory-fabricated, continuous-slot, metal channel/strut and associated fittings, accessories, and hardware required for field assembly of supports.
  - 2. Comply with MFMA-4.
- E. Hanger Rods: Threaded, zinc-plated steel unless otherwise indicated.
- F. Anchors and Fasteners:
  - 1. Unless otherwise indicated and where not otherwise restricted, use anchor and fastener types indicated for specified applications.

## **PART 3 EXECUTION**

### **3.01 EXAMINATION**

- A. Verify that field measurements are as indicated.
- B. Verify that mounting surfaces are ready to receive support and attachment components.
- C. Verify that conditions are satisfactory for installation prior to starting work.

### **3.02 INSTALLATION**

- A. Install products in accordance with manufacturer's instructions.
- B. Install hangers and supports in accordance with NECA 1.
- C. Provide independent support from building structure. Do not provide support from piping, ductwork, or other systems.
- D. Unless specifically indicated or approved by Architect, do not provide support from suspended ceiling support system or ceiling grid.
- E. Unless specifically indicated or approved by Architect, do not provide support from roof deck.
- F. Do not penetrate or otherwise notch or cut structural members without approval of Structural Engineer.

- G. Equipment Support and Attachment:
  - 1. Use metal, fabricated supports or supports assembled from metal channel/strut to support equipment as required.
  - 2. Use metal channel/strut secured to studs to support equipment surface mounted on hollow stud walls when wall strength is not sufficient to resist pull-out.
  - 3. Use metal channel/strut to support surface-mounted equipment in wet or damp locations to provide space between equipment and mounting surface.
  - 4. Securely fasten floor-mounted equipment. Do not install equipment such that it relies on its own weight for support.
- H. Secure fasteners in accordance with manufacturer's recommended torque settings.
- I. Remove temporary supports.

### **3.03 FIELD QUALITY CONTROL**

- A. See Section 014000 - Quality Requirements for additional requirements.
- B. Inspect support and attachment components for damage and defects.
- C. Repair cuts and abrasions in galvanized finishes using zinc-rich paint recommended by manufacturer. Replace components that exhibit signs of corrosion.
- D. Correct deficiencies and replace damaged or defective support and attachment components.

**END OF SECTION**

**SECTION 260533.13  
CONDUIT FOR ELECTRICAL SYSTEMS**

**PART 1 GENERAL**

**1.01 SECTION INCLUDES**

- A. Galvanized steel rigid metal conduit (RMC).
- B. Galvanized steel intermediate metal conduit (IMC).
- C. PVC-coated galvanized steel rigid metal conduit (RMC).
- D. Galvanized steel electrical metallic tubing (EMT).
- E. Rigid polyvinyl chloride (PVC) conduit.
- F. Liquidtight flexible nonmetallic conduit (LFNC).
- G. Reinforced thermosetting resin conduit (RTRC).

**1.02 RELATED REQUIREMENTS**

- A. Section 033000 - Cast-in-Place Concrete: Concrete encasement of conduits.
- B. Section 078400 - Firestopping.
- C. Section 260519 - Low-Voltage Electrical Power Conductors and Cables: Cable assemblies consisting of conductors protected by integral metal armor.
- D. Section 260526 - Grounding and Bonding for Electrical Systems.
- E. Section 260529 - Hangers and Supports for Electrical Systems.
- F. Section 260533.16 - Boxes for Electrical Systems.

**1.03 REFERENCE STANDARDS**

- A. ANSI C80.1 - American National Standard for Electrical Rigid Steel Conduit (ERSC); 2020.
- B. ANSI C80.3 - American National Standard for Electrical Metallic Tubing -- Steel (EMT-S); 2020.
- C. ANSI C80.6 - American National Standard for Electrical Intermediate Metal Conduit; 2018.
- D. NECA 1 - Standard for Good Workmanship in Electrical Construction; 2015.
- E. NECA 101 - Standard for Installing Steel Conduits (Rigid, IMC, EMT); 2020.
- F. NECA 111 - Standard for Installing Nonmetallic Raceways (RNC, ENT, LFNC); 2017.
- G. NEMA FB 1 - Fittings, Cast Metal Boxes, and Conduit Bodies for Conduit, Electrical Metallic Tubing, and Cable; 2014.
- H. NEMA RN 1 - Polyvinyl-Chloride (PVC) Externally Coated Galvanized Rigid Steel Metal Conduit and Intermediate Metal Conduit; 2018.
- I. NEMA TC 2 - Electrical Polyvinyl Chloride (PVC) Conduit; 2020.
- J. NEMA TC 3 - Polyvinyl Chloride (PVC) Fittings for Use with Rigid PVC Conduit and Tubing; 2021.
- K. NEMA TC 14 (SERIES) - Reinforced Thermosetting Resin Conduit and Fittings Series; 2015.
- L. NFPA 70 - National Electrical Code; Most Recent Edition Adopted by Authority Having Jurisdiction, Including All Applicable Amendments and Supplements.
- M. UL 6 - Electrical Rigid Metal Conduit-Steel; Current Edition, Including All Revisions.
- N. UL 514A - Metallic Outlet Boxes; Current Edition, Including All Revisions.
- O. UL 514B - Conduit, Tubing, and Cable Fittings; Current Edition, Including All Revisions.
- P. UL 651 - Schedule 40, 80, Type EB and A Rigid PVC Conduit and Fittings; Current Edition, Including All Revisions.
- Q. UL 797 - Electrical Metallic Tubing-Steel; Current Edition, Including All Revisions.
- R. UL 1242 - Electrical Intermediate Metal Conduit-Steel; Current Edition, Including All Revisions.

- S. UL 2419 - Outline of Investigation for Electrically Conductive Corrosion Resistant Compounds; Current Edition, Including All Revisions.

#### **1.04 ADMINISTRATIVE REQUIREMENTS**

- A. Coordination:
  - 1. Coordinate minimum sizes of conduits with actual type and quantity of conductors to be installed, including adjustments for conductor sizes increased for voltage drop.
  - 2. Coordinate arrangement of conduits with structural members, ductwork, piping, equipment, and other potential conflicts.
  - 3. Verify exact conduit termination locations required for boxes, enclosures, and equipment.
  - 4. Coordinate work to provide roof penetrations that preserve integrity of roofing system and do not void roof warranty.
  - 5. Notify Architect of conflicts with or deviations from Contract Documents. Obtain direction before proceeding with work.
- B. Sequencing:
  - 1. Do not begin installation of conductors and cables until installation of conduit between termination points is complete.

### **PART 2 PRODUCTS**

#### **2.01 CONDUIT APPLICATIONS**

- A. Do not use conduit and associated fittings for applications other than as permitted by NFPA 70, manufacturer's instructions, and product listing.
- B. Unless otherwise indicated and where not otherwise restricted, use conduit types indicated for specified applications. Where more than one listed application applies, comply with most restrictive requirements. Where conduit type for particular application is not specified, use galvanized steel rigid metal conduit.
- C. Underground:
  - 1. Under Slab on Grade: Use rigid PVC conduit.
  - 2. Exterior, Direct-Buried: Use stainless steel electrical metallic tubing (EMT), rigid PVC conduit, or reinforced thermosetting resin conduit (RTRC).
  - 3. Where rigid polyvinyl chloride (PVC) conduit is provided, transition to galvanized steel rigid metal conduit (RMC) or galvanized steel intermediate metal conduit (IMC) where emerging from underground.
  - 4. Where rigid polyvinyl (PVC) conduit larger than 2-inch (53 mm) trade size is provided, use galvanized steel rigid metal conduit (RMC) elbows, galvanized steel intermediate metal conduit (IMC) elbows, PVC-coated galvanized steel rigid metal conduit (RMC) elbows, or concrete-encased PVC elbows for bends.

#### **2.02 CONDUIT - GENERAL REQUIREMENTS**

- A. Comply with NFPA 70.
- B. Provide conduit, fittings, supports, and accessories required for complete raceway system.
- C. Provide products listed, classified, and labeled as suitable for purpose intended.
- D. Where conduit size is not indicated, size to comply with NFPA 70 but not less than applicable minimum size requirements specified.

#### **2.03 GALVANIZED STEEL RIGID METAL CONDUIT (RMC)**

- A. Description: NFPA 70, Type RMC galvanized steel rigid metal conduit complying with ANSI C80.1 and listed and labeled as complying with UL 6.
- B. Fittings:
  - 1. Nonhazardous Locations: Use fittings complying with NEMA FB 1 and listed and labeled as complying with UL 514B or UL 6.
  - 2. Material: Use steel or malleable iron.
  - 3. Connectors and Couplings: Use threaded type fittings only. Threadless fittings, including set screw and compression/gland types, are not permitted.

#### **2.04 GALVANIZED STEEL INTERMEDIATE METAL CONDUIT (IMC)**

- A. Description: NFPA 70, Type IMC galvanized steel intermediate metal conduit complying with ANSI C80.6 and listed and labeled as complying with UL 1242.
- B. Fittings:
  - 1. Nonhazardous Locations: Use fittings complying with NEMA FB 1 and listed and labeled as complying with UL 514B or UL 1242.
  - 2. Material: Use steel or malleable iron.
  - 3. Connectors and Couplings: Use threaded type fittings only. Threadless fittings, including set screw and compression/gland types, are not permitted.

#### **2.05 PVC-COATED GALVANIZED STEEL RIGID METAL CONDUIT (RMC)**

- A. Description: NFPA 70, Type RMC galvanized steel rigid metal conduit with external polyvinyl chloride (PVC) coating complying with NEMA RN 1 and listed and labeled as complying with UL 6.
- B. Exterior Coating: Polyvinyl chloride (PVC), nominal thickness of 40 mil, 0.040 inch (1.02 mm).
- C. PVC-Coated Boxes and Fittings:
  - 1. Manufacturer: Same as manufacturer of PVC-coated conduit to be installed.
  - 2. Nonhazardous Locations: Use boxes and fittings listed and labeled as complying with UL 514A, UL 514B, or UL 6.
  - 3. Material: Use steel or malleable iron.
  - 4. Exterior Coating: Polyvinyl chloride (PVC), minimum thickness of 40 mil, 0.040 inch (1.02 mm).
- D. PVC-Coated Supports: Furnish with exterior coating of polyvinyl chloride (PVC), minimum thickness of 15 mil, 0.015 inch (0.38 mm).

#### **2.06 GALVANIZED STEEL ELECTRICAL METALLIC TUBING (EMT)**

- A. Description: NFPA 70, Type EMT galvanized steel electrical metallic tubing complying with ANSI C80.3 and listed and labeled as complying with UL 797.
- B. Fittings:
  - 1. Description: Fittings complying with NEMA FB 1 and listed and labeled as complying with UL 514B.
  - 2. Material: Use steel or malleable iron.
  - 3. Connectors and Couplings: Use compression/gland or set-screw type.
    - a. Do not use indenter type connectors and couplings.

#### **2.07 RIGID POLYVINYL CHLORIDE (PVC) CONDUIT**

- A. Description: NFPA 70, Type PVC rigid polyvinyl chloride conduit complying with NEMA TC 2 and listed and labeled as complying with UL 651; Schedule 40 unless otherwise indicated, Schedule 80 where subject to physical damage; rated for use with conductors rated 90 degrees C.
- B. Fittings:
  - 1. Manufacturer: Same as manufacturer of conduit to be connected.
  - 2. Description: Fittings complying with NEMA TC 3 and listed and labeled as complying with UL 651; material to match conduit.

#### **2.08 REINFORCED THERMOSETTING RESIN CONDUIT (RTRC)**

- A. Description: NFPA 70, Type RTRC reinforced thermosetting resin conduit complying with NEMA TC 14 (SERIES).
- B. Supports: As recommended by manufacturer.
- C. Fittings: Same type and manufacturer as conduit to be connected.

#### **2.09 ACCESSORIES**

- A. Conduit Joint Compound: Corrosion-resistant, electrically conductive compound listed as complying with UL 2419; suitable for use with conduit to be installed.

- B. Solvent Cement for PVC Conduit and Fittings: As recommended by manufacturer of conduit and fittings to be installed.
- C. Epoxy Adhesive for RTRC Conduit and Fittings: As recommended by manufacturer of conduit and fittings to be installed.

## **PART 3 EXECUTION**

### **3.01 EXAMINATION**

- A. Verify that field measurements are as indicated.
- B. Verify that mounting surfaces are ready to receive conduits.
- C. Verify that conditions are satisfactory for installation prior to starting work.

### **3.02 INSTALLATION**

- A. Install products in accordance with manufacturer's instructions.
- B. Install conduit in accordance with NECA 1.
- C. Galvanized Steel Rigid Metal Conduit (RMC): Install in accordance with NECA 101.
- D. Intermediate Metal Conduit (IMC): Install in accordance with NECA 101.
- E. PVC-Coated Galvanized Steel Rigid Metal Conduit (RMC): Install using only tools approved by manufacturer.
- F. Rigid Polyvinyl Chloride (PVC) Conduit: Install in accordance with NECA 111.
- G. Conduit Routing:
  - 1. Unless dimensioned, conduit routing indicated is diagrammatic.
  - 2. When conduit destination is indicated without specific routing, determine exact routing required.
  - 3. Conceal conduits unless specifically indicated to be exposed.
  - 4. Conduits in the following areas may be exposed, unless otherwise indicated:
    - a. Electrical rooms.
    - b. Mechanical equipment rooms.
  - 5. Unless otherwise approved, do not route exposed conduits:
    - a. Across floors.
    - b. Across roofs.
    - c. Across top of parapet walls.
    - d. Across building exterior surfaces.
  - 6. Conduits installed underground or embedded in concrete may be routed in shortest possible manner unless otherwise indicated. Route other conduits parallel or perpendicular to building structure and surfaces, following surface contours where practical.
  - 7. Arrange conduit to maintain adequate headroom, clearances, and access.
  - 8. Arrange conduit to provide no more than equivalent of four 90-degree bends between pull points.
  - 9. Arrange conduit to provide no more than 150 feet (46 m) between pull points.
  - 10. Route conduits above water and drain piping where possible.
  - 11. Arrange conduit to prevent moisture traps. Provide drain fittings at low points and at sealing fittings where moisture may collect.
- H. Conduit Support:
  - 1. Secure and support conduits in accordance with NFPA 70 using suitable supports and methods approved by authorities having jurisdiction; see Section 260529.
  - 2. Provide independent support from building structure. Do not provide support from piping, ductwork, or other systems.
  - 3. Installation Above Suspended Ceilings: Do not provide support from ceiling support system. Do not provide support from ceiling grid or allow conduits to lay on ceiling tiles.
  - 4. Use conduit strap to support single surface-mounted conduit.

- a. Use clamp back spacer with conduit strap for damp and wet locations to provide space between conduit and mounting surface.
  - 5. Use metal channel/strut with accessory conduit clamps to support multiple parallel surface-mounted conduits.
- I. Connections and Terminations:
  - 1. Use approved zinc-rich paint or conduit joint compound on field-cut threads of galvanized steel conduits prior to making connections.
  - 2. Where two threaded conduits must be joined and neither can be rotated, use three-piece couplings or split couplings. Do not use running threads.
  - 3. Use suitable adapters where required to transition from one type of conduit to another.
  - 4. Terminate threaded conduits in boxes and enclosures using threaded hubs or double lock nuts for dry locations and raintight hubs for wet locations.
  - 5. Provide insulating bushings, insulated throats, or listed metal fittings with smooth, rounded edges at conduit terminations to protect conductors.
  - 6. Secure joints and connections to provide mechanical strength and electrical continuity.
- J. Penetrations:
  - 1. Do not penetrate or otherwise notch or cut structural members, including footings and grade beams, without approval of Structural Engineer.
  - 2. Make penetrations perpendicular to surfaces unless otherwise indicated.
  - 3. Provide sleeves for penetrations as indicated or as required to facilitate installation. Set sleeves flush with exposed surfaces unless otherwise indicated or required.
  - 4. Conceal bends for conduit risers emerging above ground.
  - 5. Where conduits penetrate waterproof membrane, seal as required to maintain integrity of membrane.
  - 6. Make penetrations for roof-mounted equipment within associated equipment openings and curbs where possible to minimize roofing system penetrations. Where penetrations are necessary, seal as indicated or as required to preserve integrity of roofing system and maintain roof warranty.
  - 7. Install firestopping to preserve fire resistance rating of partitions and other elements; see Section 078400.
- K. Concrete Encasement: Where conduits not otherwise embedded within concrete are indicated to be concrete-encased, provide minimum concrete cover of 3 inches (76 mm) on all sides unless otherwise indicated; see Section 033000.
- L. Conduit Movement Provisions: Where conduits are subject to movement, provide expansion and expansion/deflection fittings to prevent damage to enclosed conductors or connected equipment. This includes, but is not limited to:
  - 1. Where conduits cross structural joints intended for expansion, contraction, or deflection.
  - 2. Where calculated in accordance with NFPA 70 for rigid polyvinyl chloride (PVC) conduit installed above ground to compensate for thermal expansion and contraction.
  - 3. Where calculated in accordance with NFPA 70 for reinforced thermosetting resin conduit (RTRC) conduit installed above ground to compensate for thermal expansion and contraction.
  - 4. Where conduits are subject to earth movement by settlement or frost.
- M. Conduit Sealing:
  - 1. Use foam conduit sealant to prevent entry of moisture and gases. This includes, but is not limited to:
    - a. Where conduits enter building from outside.
    - b. Where service conduits enter building from underground distribution system.
    - c. Where conduits enter building from underground.
    - d. Where conduits may transport moisture to contact live parts.
  - 2. Where conduits cross barriers between areas of potential substantial temperature differential, use foam conduit sealant at accessible point near penetration to prevent condensation. This includes, but is not limited to:
    - a. Where conduits pass from outdoors into conditioned interior spaces.

- b. Where conduits pass from unconditioned interior spaces into conditioned interior spaces.

N. Provide grounding and bonding; see Section 260526.

### **3.03 FIELD QUALITY CONTROL**

- A. See Section 014000 - Quality Requirements for additional requirements.
- B. Repair cuts and abrasions in galvanized finishes using zinc-rich paint recommended by manufacturer. Replace components that exhibit signs of corrosion.
- C. Where coating of PVC-coated galvanized steel rigid metal conduit (RMC) contains cuts or abrasions, repair in accordance with manufacturer's instructions.
- D. Correct deficiencies and replace damaged or defective conduits.

### **3.04 CLEANING**

- A. Clean interior of conduits to remove moisture and foreign matter.

### **3.05 PROTECTION**

- A. Immediately after installation of conduit, use suitable manufactured plugs to provide protection from entry of moisture and foreign material and do not remove until ready for installation of conductors.

**END OF SECTION**



**SECTION 260533.16**  
**BOXES FOR ELECTRICAL SYSTEMS**

**PART 1 GENERAL**

**1.01 SECTION INCLUDES**

- A. Outlet and device boxes up to 100 cubic inches (1,650 cu cm), including those used as junction and pull boxes.
- B. Cabinets and enclosures, including junction and pull boxes larger than 100 cubic inches (1,650 cu cm).

**1.02 RELATED REQUIREMENTS**

- A. Section 083100 - Access Doors and Panels: Panels for maintaining access to concealed boxes.
- B. Section 260526 - Grounding and Bonding for Electrical Systems.
- C. Section 260529 - Hangers and Supports for Electrical Systems.
- D. Section 260533.13 - Conduit for Electrical Systems:
  - 1. Conduit bodies and other fittings.
- E. Section 262726 - Wiring Devices:
  - 1. Wall plates.

**1.03 REFERENCE STANDARDS**

- A. NECA 1 - Standard for Good Workmanship in Electrical Construction; 2015.
- B. NECA 130 - Standard for Installing and Maintaining Wiring Devices; 2016.
- C. NEMA 250 - Enclosures for Electrical Equipment (1000 Volts Maximum); 2020.
- D. NEMA FB 1 - Fittings, Cast Metal Boxes, and Conduit Bodies for Conduit, Electrical Metallic Tubing, and Cable; 2014.
- E. NEMA OS 1 - Sheet-Steel Outlet Boxes, Device Boxes, Covers, and Box Supports; 2013 (Reaffirmed 2020).
- F. NFPA 70 - National Electrical Code; Most Recent Edition Adopted by Authority Having Jurisdiction, Including All Applicable Amendments and Supplements.
- G. UL 50 - Enclosures for Electrical Equipment, Non-Environmental Considerations; Current Edition, Including All Revisions.
- H. UL 50E - Enclosures for Electrical Equipment, Environmental Considerations; Current Edition, Including All Revisions.
- I. UL 508A - Industrial Control Panels; Current Edition, Including All Revisions.
- J. UL 514A - Metallic Outlet Boxes; Current Edition, Including All Revisions.

**1.04 ADMINISTRATIVE REQUIREMENTS**

- A. Coordination:
  - 1. Coordinate the work with other trades to avoid placement of ductwork, piping, equipment, or other potential obstructions within the dedicated equipment spaces and working clearances for electrical equipment required by NFPA 70.
  - 2. Coordinate arrangement of electrical equipment with the dimensions and clearance requirements of the actual equipment to be installed.
  - 3. Coordinate minimum sizes of boxes with the actual installed arrangement of conductors, clamps, support fittings, and devices, calculated according to NFPA 70.
  - 4. Coordinate minimum sizes of pull boxes with the actual installed arrangement of connected conduits, calculated according to NFPA 70.
  - 5. Coordinate the placement of boxes with millwork, furniture, devices, equipment, etc. installed under other sections or by others.
  - 6. Coordinate the work with other trades to preserve insulation integrity.

7. Coordinate the work with other trades to provide walls suitable for installation of flush-mounted boxes where indicated.
8. Notify Architect of any conflicts with or deviations from Contract Documents. Obtain direction before proceeding with work.

#### **1.05 SUBMITTALS**

- A. See Section 013000 - Administrative Requirements, for submittal procedures.
- B. Product Data: Provide manufacturer's standard catalog pages and data sheets for cabinets and enclosures, boxes for hazardous (classified) locations, floor boxes, and underground boxes/enclosures.

#### **1.06 QUALITY ASSURANCE**

- A. Comply with requirements of NFPA 70.

#### **1.07 DELIVERY, STORAGE, AND HANDLING**

- A. Receive, inspect, handle, and store products in accordance with manufacturer's instructions.

### **PART 2 PRODUCTS**

#### **2.01 BOXES**

- A. General Requirements:
  1. Do not use boxes and associated accessories for applications other than as permitted by NFPA 70 and product listing.
  2. Provide all boxes, fittings, supports, and accessories required for a complete raceway system and to accommodate devices and equipment to be installed.
  3. Provide products listed, classified, and labeled as suitable for the purpose intended.
  4. Where box size is not indicated, size to comply with NFPA 70 but not less than applicable minimum size requirements specified.
  5. Provide grounding terminals within boxes where equipment grounding conductors terminate.
- B. Outlet and Device Boxes Up to 100 cubic inches (1,650 cu cm), Including Those Used as Junction and Pull Boxes:
  1. Use sheet-steel boxes for dry locations unless otherwise indicated or required.
  2. Use cast iron boxes or cast aluminum boxes for damp or wet locations unless otherwise indicated or required; furnish with compatible weatherproof gasketed covers.
  3. Use suitable concrete type boxes where flush-mounted in concrete.
  4. Use suitable masonry type boxes where flush-mounted in masonry walls.
  5. Use raised covers suitable for the type of wall construction and device configuration where required.
  6. Use shallow boxes where required by the type of wall construction.
  7. Do not use "through-wall" boxes designed for access from both sides of wall.
  8. Sheet-Steel Boxes: Comply with NEMA OS 1, and list and label as complying with UL 514A.
  9. Cast Metal Boxes: Comply with NEMA FB 1, and list and label as complying with UL 514A; furnish with threaded hubs.
  10. Boxes for Supporting Luminaires and Ceiling Fans: Listed as suitable for the type and weight of load to be supported; furnished with fixture stud to accommodate mounting of luminaire where required.
  11. Boxes for Ganged Devices: Use multigang boxes of single-piece construction. Do not use field-connected gangable boxes unless specifically indicated or permitted.
  12. Wall Plates: Comply with Section 262726.
- C. Cabinets and Enclosures, Including Junction and Pull Boxes Larger Than 100 cubic inches (1,650 cu cm):
  1. Comply with NEMA 250, and list and label as complying with UL 50 and UL 50E, or UL 508A.
  2. NEMA 250 Environment Type, Unless Otherwise Indicated:

3. Junction and Pull Boxes Larger Than 100 cubic inches (1,650 cu cm):
  - a. Provide screw-cover or hinged-cover enclosures unless otherwise indicated.

### **PART 3 EXECUTION**

#### **3.01 EXAMINATION**

- A. Verify that field measurements are as indicated.
- B. Verify that mounting surfaces are ready to receive boxes.
- C. Verify that conditions are satisfactory for installation prior to starting work.

#### **3.02 INSTALLATION**

- A. Install products in accordance with manufacturer's instructions.
- B. Install boxes in accordance with NECA 1 (general workmanship) and, where applicable, NECA 130, including mounting heights specified in those standards where mounting heights are not indicated.
- C. Arrange equipment to provide minimum clearances in accordance with manufacturer's instructions and NFPA 70.
- D. Flush-mount boxes in finished areas unless specifically indicated to be surface-mounted.
- E. Unless otherwise indicated, boxes may be surface-mounted where exposed conduits are indicated or permitted.
- F. Box Locations:
  1. Locate boxes to be accessible. Provide access panels in accordance with Section 083100 as required where approved by the Architect.
  2. Unless otherwise indicated, where multiple outlet boxes are installed at the same location at different mounting heights, install along a common vertical center line.
  3. Do not install flush-mounted boxes on opposite sides of walls back-to-back. Provide minimum 6 inches (150 mm) horizontal separation unless otherwise indicated.
- G. Box Supports:
  1. Secure and support boxes in accordance with NFPA 70 and Section 260529 using suitable supports and methods approved by the authority having jurisdiction.
  2. Provide independent support from building structure except for cast metal boxes (other than boxes used for fixture support) supported by threaded conduit connections in accordance with NFPA 70. Do not provide support from piping, ductwork, or other systems.
- H. Install boxes plumb and level.
- I. Flush-Mounted Boxes:
  1. Install boxes in noncombustible materials such as concrete, tile, gypsum, plaster, etc. so that front edge of box or associated raised cover is not set back from finished surface more than 1/4 inch (6 mm) or does not project beyond finished surface.
  2. Install boxes in combustible materials such as wood so that front edge of box or associated raised cover is flush with finished surface.
  3. Repair rough openings around boxes in noncombustible materials such as concrete, tile, gypsum, plaster, etc. so that there are no gaps or open spaces greater than 1/8 inch (3 mm) at the edge of the box.
- J. Install boxes as required to preserve insulation integrity.
- K. Install permanent barrier between ganged wiring devices when voltage between adjacent devices exceeds 300 V.
- L. Install firestopping to preserve fire resistance rating of partitions and other elements, using materials and methods specified in Section 078400.
- M. Close unused box openings.
- N. Install blank wall plates on junction boxes and on outlet boxes with no devices or equipment installed or designated for future use.

O. Provide grounding and bonding in accordance with Section 260526.

**3.03 CLEANING**

A. Clean interior of boxes to remove dirt, debris, plaster and other foreign material.

**3.04 PROTECTION**

A. Immediately after installation, protect boxes from entry of moisture and foreign material until ready for installation of conductors.

**END OF SECTION**

**SECTION 260553  
IDENTIFICATION FOR ELECTRICAL SYSTEMS**

**PART 1 GENERAL**

**1.01 RELATED REQUIREMENTS**

- A. Section 260519 - Low-Voltage Electrical Power Conductors and Cables: Color coding for power conductors and cables 600 V and less; vinyl color coding electrical tape.

**1.02 REFERENCE STANDARDS**

- A. NFPA 70 - National Electrical Code; Most Recent Edition Adopted by Authority Having Jurisdiction, Including All Applicable Amendments and Supplements.
- B. UL 969 - Marking and Labeling Systems; Current Edition, Including All Revisions.

**1.03 ADMINISTRATIVE REQUIREMENTS**

- A. Coordination:
  - 1. Verify final designations for equipment, systems, and components to be identified prior to fabrication of identification products.
- B. Sequencing:
  - 1. Do not conceal items to be identified, in locations such as above suspended ceilings, until identification products have been installed.
  - 2. Do not install identification products until final surface finishes and painting are complete.

**PART 2 PRODUCTS**

**2.01 IDENTIFICATION REQUIREMENTS**

- A. Identification for Equipment:
  - 1. Use identification nameplate to identify each piece of electrical distribution and control equipment and associated sections, compartments, and components.
    - a. Panelboards:
      - 1) Identify power source and circuit number. Include location when not within sight of equipment.
      - 2) Use typewritten circuit directory to identify load(s) served for panelboards with a door. Identify spares and spaces using pencil.
      - 3) For power panelboards without a door, use identification nameplate to identify load(s) served for each branch device. Do not identify spares and spaces.
  - 2. Available Fault Current Documentation: Use identification label to identify the available fault current and date calculations were performed at locations requiring documentation by NFPA 70 including but not limited to the following.
    - a. Service equipment.
    - b. Industrial control panels.
    - c. Motor control centers.
    - d. Elevator control panels.
    - e. Industrial machinery.
  - 3. Arc Flash Hazard Warning Labels: Use warning labels to identify arc flash hazards for electrical equipment, such as switchboards, panelboards, industrial control panels, meter socket enclosures, and motor control centers that are likely to require examination, adjustment, servicing, or maintenance while energized.
- B. Identification for Conductors and Cables:
  - 1. Color Coding for Power Conductors 600 V and Less: Comply with Section 260519.
  - 2. Use identification nameplate or identification label to identify color code for ungrounded and grounded power conductors inside door or enclosure at each piece of feeder or branch-circuit distribution equipment when premises has feeders or branch circuits served by more than one nominal voltage system.
- C. Identification for Luminaires:
  - 1. Use permanent red dot on luminaire frame to identify luminaires connected to emergency power system.

## 2.02 IDENTIFICATION NAMEPLATES AND LABELS

- A. Identification Nameplates:
  - 1. Materials:
    - a. Indoor Clean, Dry Locations: Use plastic nameplates.
    - b. Outdoor Locations: Use plastic, stainless steel, or aluminum nameplates suitable for exterior use.
  - 2. Plastic Nameplates: Two-layer or three-layer laminated acrylic or electrically non-conductive phenolic with beveled edges; minimum thickness of 1/16 inch (1.6 mm); engraved text.
  - 3. Stainless Steel Nameplates: Minimum thickness of 1/32 inch (0.8 mm); engraved or laser-etched text.
  - 4. Aluminum Nameplates: Anodized; minimum thickness of 1/32 inch (0.8 mm); engraved or laser-etched text.
  - 5. Mounting Holes for Mechanical Fasteners: Two, centered on sides for sizes up to 1 inch (25 mm) high; Four, located at corners for larger sizes.
- B. Identification Labels:
  - 1. Materials: Use self-adhesive laminated plastic labels; UV, chemical, water, heat, and abrasion resistant.
  - 2. Text: Use factory pre-printed or machine-printed text. Do not use handwritten text unless otherwise indicated.

## 2.03 WIRE AND CABLE MARKERS

- A. Markers for Conductors and Cables: Use wrap-around self-adhesive vinyl cloth, wrap-around self-adhesive vinyl self-laminating, heat-shrink sleeve, plastic sleeve, plastic clip-on, or vinyl split sleeve type markers suitable for the conductor or cable to be identified.
- B. Markers for Conductor and Cable Bundles: Use plastic marker tags secured by nylon cable ties.
- C. Legend: Power source and circuit number or other designation indicated.
- D. Text: Use factory pre-printed or machine-printed text, all capitalized unless otherwise indicated.
- E. Minimum Text Height: 1/8 inch (3 mm).
- F. Color: Black text on white background unless otherwise indicated.

## 2.04 UNDERGROUND WARNING TAPE

- A. Materials: Use non-detectable type polyethylene tape suitable for direct burial, unless otherwise indicated.
- B. Non-detectable Type Tape: 6 inches (152 mm) wide, with minimum thickness of 4 mil (0.1 mm).
- C. Legend: Type of service, continuously repeated over full length of tape.
- D. Color:

## 2.05 WARNING SIGNS AND LABELS

- A. Comply with ANSI Z535.2 or ANSI Z535.4 as applicable.
- B. Warning Signs:
  - 1. Materials:
  - 2. Minimum Size: 7 by 10 inches (178 by 254 mm) unless otherwise indicated.
- C. Warning Labels:
  - 1. Materials: Use factory pre-printed or machine-printed self-adhesive polyester or self-adhesive vinyl labels; UV, chemical, water, heat, and abrasion resistant; produced using materials recognized to UL 969.
  - 2. Machine-Printed Labels: Use thermal transfer process printing machines and accessories recommended by label manufacturer.
  - 3. Minimum Size: 2 by 4 inches (51 mm by 102 mm) unless otherwise indicated.

## **PART 3 EXECUTION**

### **3.01 PREPARATION**

- A. Clean surfaces to receive adhesive products according to manufacturer's instructions.

### **3.02 INSTALLATION**

- A. Install products in accordance with manufacturer's instructions.
- B. Install identification products to be plainly visible for examination, adjustment, servicing, and maintenance. Unless otherwise indicated, locate products as follows:
  - 1. Surface-Mounted Equipment: Enclosure front.
  - 2. Flush-Mounted Equipment: Inside of equipment door.
  - 3. Free-Standing Equipment: Enclosure front; also enclosure rear for equipment with rear access.
  - 4. Elevated Equipment: Legible from the floor or working platform.
  - 5. Branch Devices: Adjacent to device.
  - 6. Interior Components: Legible from the point of access.
  - 7. Conductors and Cables: Legible from the point of access.
- C. Install identification products centered, level, and parallel with lines of item being identified.
- D. Secure nameplates to exterior surfaces of enclosures using stainless steel screws and to interior surfaces using self-adhesive backing or epoxy cement.
- E. Install self-adhesive labels and markers to achieve maximum adhesion, with no bubbles or wrinkles and edges properly sealed.
- F. Install underground warning tape above buried lines with one tape per trench at 3 inches (75 mm) below finished grade.
- G. Mark all handwritten text, where permitted, to be neat and legible.

### **3.03 FIELD QUALITY CONTROL**

- A. See Section 014000 - Quality Requirements, for additional requirements.
- B. Replace self-adhesive labels and markers that exhibit bubbles, wrinkles, curling or other signs of improper adhesion.

**END OF SECTION**

**SECTION 260583  
WIRING CONNECTIONS**

**PART 1 GENERAL**

**1.01 SECTION INCLUDES**

- A. Electrical connections to equipment.

**1.02 RELATED REQUIREMENTS**

- A. Section 260519 - Low-Voltage Electrical Power Conductors and Cables.
- B. Section 260533.13 - Conduit for Electrical Systems.
- C. Section 260533.16 - Boxes for Electrical Systems.
- D. Section 262726 - Wiring Devices.
- E. Section 262816.16 - Enclosed Switches.

**1.03 REFERENCE STANDARDS**

- A. NEMA WD 1 - General Color Requirements for Wiring Devices; 1999 (Reaffirmed 2020).
- B. NEMA WD 6 - Wiring Devices - Dimensional Specifications; 2021.
- C. NFPA 70 - National Electrical Code; Most Recent Edition Adopted by Authority Having Jurisdiction, Including All Applicable Amendments and Supplements.

**1.04 ADMINISTRATIVE REQUIREMENTS**

- A. Coordination:
  - 1. Obtain and review shop drawings, product data, manufacturer's wiring diagrams, and manufacturer's instructions for equipment furnished under other sections.
  - 2. Determine connection locations and requirements.
- B. Sequencing:
  - 1. Install rough-in of electrical connections before installation of equipment is required.
  - 2. Make electrical connections before required start-up of equipment.

**PART 2 PRODUCTS**

**2.01 MATERIALS**

- A. Cords and Caps: NEMA WD 6; match receptacle configuration at outlet provided for equipment.
  - 1. Colors: Comply with NEMA WD 1.
  - 2. Cord Construction: NFPA 70, Type SO, multiconductor flexible cord with identified equipment grounding conductor, suitable for use in damp locations.
  - 3. Size: Suitable for connected load of equipment, length of cord, and rating of branch circuit overcurrent protection.
- B. Disconnect Switches: As specified in Section 262816.16 and in individual equipment sections.
- C. Wiring Devices: As specified in Section 262726.
- D. Flexible Conduit: As specified in Section 260533.13.
- E. Wire and Cable: As specified in Section 260519.
- F. Boxes: As specified in Section 260533.16.

**2.02 EQUIPMENT CONNECTIONS**

**PART 3 EXECUTION**

**3.01 EXAMINATION**

- A. Verify that equipment is ready for electrical connection, wiring, and energization.

**3.02 ELECTRICAL CONNECTIONS**

- A. Make electrical connections in accordance with equipment manufacturer's instructions.



- B. Make conduit connections to equipment using flexible conduit. Use liquidtight flexible conduit with watertight connectors in damp or wet locations.
- C. Connect heat producing equipment using wire and cable with insulation suitable for temperatures encountered.
- D. Provide receptacle outlet to accommodate connection with attachment plug.
- E. Provide cord and cap where field-supplied attachment plug is required.
- F. Install suitable strain-relief clamps and fittings for cord connections at outlet boxes and equipment connection boxes.
- G. Install disconnect switches, controllers, control stations, and control devices to complete equipment wiring requirements.
- H. Install terminal block jumpers to complete equipment wiring requirements.
- I. Install interconnecting conduit and wiring between devices and equipment to complete equipment wiring requirements.

**END OF SECTION**

**SECTION 260923  
LIGHTING CONTROL DEVICES**

**PART 1 GENERAL**

**1.01 SECTION INCLUDES**

- A. Occupancy sensors.

**1.02 RELATED REQUIREMENTS**

- A. Section 260526 - Grounding and Bonding for Electrical Systems.
- B. Section 260529 - Hangers and Supports for Electrical Systems
- C. Section 260533.16 - Boxes for Electrical Systems.
- D. Section 260553 - Identification for Electrical Systems: Identification products and requirements.
- E. Section 262726 - Wiring Devices: Devices for manual control of lighting, including wall switches, wall dimmers, and fan speed controllers.

**1.03 REFERENCE STANDARDS**

- A. NECA 1 - Standard for Good Workmanship in Electrical Construction; 2015.
- B. NECA 130 - Standard for Installing and Maintaining Wiring Devices; 2016.
- C. NFPA 70 - National Electrical Code; Most Recent Edition Adopted by Authority Having Jurisdiction, Including All Applicable Amendments and Supplements.

**1.04 ADMINISTRATIVE REQUIREMENTS**

**1.05 SUBMITTALS**

- A. See Section 013000 - Administrative Requirements, for submittal procedures.
- B. Product Data: Include ratings, configurations, standard wiring diagrams, dimensions, colors, service condition requirements, and installed features.
- C. Shop Drawings:

**1.06 QUALITY ASSURANCE**

- A. Comply with requirements of NFPA 70.

**1.07 DELIVERY, STORAGE, AND PROTECTION**

- A. Store products in a clean, dry space in original manufacturer's packaging in accordance with manufacturer's written instructions until ready for installation.

**1.08 FIELD CONDITIONS**

**1.09 WARRANTY**

- A. See Section 017800 - Closeout Submittals, for additional warranty requirements.
- B. Provide five year manufacturer warranty for all occupancy sensors.

**PART 2 PRODUCTS**

**2.01 LIGHTING CONTROL DEVICES - GENERAL REQUIREMENTS**

- A. Provide products listed, classified, and labeled as suitable for the purpose intended.
- B. Unless specifically indicated to be excluded, provide all required conduit, wiring, connectors, hardware, components, accessories, etc. as required for a complete operating system.

**2.02 OCCUPANCY SENSORS**

- A. All Occupancy Sensors:
  - 1. Description: Factory-assembled commercial specification grade devices for indoor use capable of sensing both major motion, such as walking, and minor motion, such as small desktop level movements, according to published coverage areas, for automatic control of load indicated.
  - 2. Sensor Technology:

3. Provide LED to visually indicate motion detection with separate color LEDs for each sensor type in dual technology units.
  4. Operation: Unless otherwise indicated, occupancy sensor to turn load on when occupant presence is detected and to turn load off when no occupant presence is detected during an adjustable turn-off delay time interval.
  5. Turn-Off Delay: Field adjustable, with time delay settings up to 30 minutes.
  6. Compatibility (Non-Dimming Sensors): Suitable for controlling incandescent lighting, low-voltage lighting with electronic and magnetic transformers, fluorescent lighting with electronic and magnetic ballasts, and fractional motor loads, with no minimum load requirements.
- B. Wall Switch Occupancy Sensors:
1. All Wall Switch Occupancy Sensors:
    - a. Description: Occupancy sensors designed for installation in standard wall box at standard wall switch mounting height with a field of view of 180 degrees, integrated manual control capability, and no leakage current to load in off mode.
    - b. Manual-Off Override Control: When used to turn off load while in automatic-on mode, unit to revert back to automatic mode after no occupant presence is detected during the delayed-off time interval.
- C. Ceiling Mounted Occupancy Sensors:
1. All Ceiling Mounted Occupancy Sensors:
    - a. Description: Low profile occupancy sensors designed for ceiling installation.
    - b. Unless otherwise indicated or required to control the load indicated on drawings, provide low voltage units, for use with separate compatible accessory power packs.
  2. Passive Infrared/Ultrasonic Dual Technology Ceiling Mounted Occupancy Sensors:

## **PART 3 EXECUTION**

### **3.01 EXAMINATION**

- A. Verify that field measurements are as indicated.
- B. Verify that outlet boxes are installed in proper locations and at proper mounting heights and are properly sized to accommodate devices and conductors in accordance with NFPA 70.
- C. Verify that openings for outlet boxes are neatly cut and will be completely covered by devices or wall plates.
- D. Verify that final surface finishes are complete, including painting.
- E. Verify that branch circuit wiring installation is completed, tested, and ready for connection to lighting control devices.
- F. Verify that the service voltage and ratings of lighting control devices are appropriate for the service voltage and load requirements at the location to be installed.
- G. Verify that conditions are satisfactory for installation prior to starting work.

### **3.02 PREPARATION**

- A. Provide extension rings to bring outlet boxes flush with finished surface.
- B. Clean dirt, debris, plaster, and other foreign materials from outlet boxes.

### **3.03 INSTALLATION**

- A. Install lighting control devices in accordance with NECA 1 (general workmanship) and, where applicable, NECA 130, including mounting heights specified in those standards unless otherwise indicated.
- B. Coordinate locations of outlet boxes provided under Section 260533.16 as required for installation of lighting control devices provided under this section.
- C. Install lighting control devices in accordance with manufacturer's instructions.
- D. Unless otherwise indicated, connect lighting control device grounding terminal or conductor to branch circuit equipment grounding conductor and to outlet box with bonding jumper.

- E. Install lighting control devices plumb and level, and held securely in place.
- F. Where required and not furnished with lighting control device, provide wall plate in accordance with Section 262726.
- G. Provide required supports in accordance with Section 260529.
- H. Where applicable, install lighting control devices and associated wall plates to fit completely flush to mounting surface with no gaps and rough opening completely covered without strain on wall plate. Repair or reinstall improperly installed outlet boxes or improperly sized rough openings. Do not use oversized wall plates in lieu of meeting this requirement.
- I. Occupancy Sensor Locations:
  - 1. Locate ultrasonic and dual technology passive infrared/ultrasonic occupancy sensors a minimum of 4 feet (1.2 m) from air supply ducts or other sources of heavy air flow and as per manufacturer's recommendations, in order to minimize false triggers.

### **3.04 ADJUSTING**

- A. Adjust devices and wall plates to be flush and level.
- B. Adjust occupancy sensor settings to minimize undesired activations while optimizing energy savings, and to achieve desired function as indicated or as directed by Architect.
- C. Where indicated or as directed by Architect, install factory masking material or adjust integral blinders on passive infrared (PIR) and dual technology occupancy sensor lenses to block undesired motion detection.

### **3.05 CLEANING**

- A. Clean exposed surfaces to remove dirt, paint, or other foreign material and restore to match original factory finish.

### **3.06 CLOSEOUT ACTIVITIES**

- A. Training: Train Owner's personnel on operation, adjustment, programming, and maintenance of lighting control devices.
  - 1. Use operation and maintenance manual as training reference, supplemented with additional training materials as required.

**END OF SECTION**

## **SECTION 262416 PANELBOARDS**

### **PART 1 GENERAL**

#### **1.01 SECTION INCLUDES**

- A. Lighting and appliance panelboards.
- B. Load centers.
- C. Overcurrent protective devices for panelboards.

#### **1.02 RELATED REQUIREMENTS**

- A. Section 260526 - Grounding and Bonding for Electrical Systems.
- B. Section 260529 - Hangers and Supports for Electrical Systems.
- C. Section 260553 - Identification for Electrical Systems: Identification products and requirements.
- D. Section 264300 - Surge Protective Devices.

#### **1.03 REFERENCE STANDARDS**

- A. FS W-C-375 - Circuit Breakers, Molded Case; Branch Circuit and Service; 2013e, with Amendments (2022).
- B. NECA 1 - Standard for Good Workmanship in Electrical Construction; 2015.
- C. NECA 407 - Standard for Installing and Maintaining Panelboards; 2015.
- D. NEMA 250 - Enclosures for Electrical Equipment (1000 Volts Maximum); 2020.
- E. NEMA PB 1 - Panelboards; 2011.
- F. NEMA PB 1.1 - General Instructions for Proper Installation, Operation and Maintenance of Panelboards Rated 1000 Volts or Less; 2023.
- G. NFPA 70 - National Electrical Code; Most Recent Edition Adopted by Authority Having Jurisdiction, Including All Applicable Amendments and Supplements.
- H. UL 50 - Enclosures for Electrical Equipment, Non-Environmental Considerations; Current Edition, Including All Revisions.
- I. UL 50E - Enclosures for Electrical Equipment, Environmental Considerations; Current Edition, Including All Revisions.
- J. UL 67 - Panelboards; Current Edition, Including All Revisions.
- K. UL 489 - Molded-Case Circuit Breakers, Molded-Case Switches and Circuit Breaker Enclosures; Current Edition, Including All Revisions.

#### **1.04 ADMINISTRATIVE REQUIREMENTS**

- A. Coordination:
  - 1. Coordinate the work with other trades to avoid placement of ductwork, piping, equipment, or other potential obstructions within the dedicated equipment spaces and working clearances for electrical equipment required by NFPA 70.
  - 2. Coordinate arrangement of electrical equipment with the dimensions and clearance requirements of the actual equipment to be installed.
  - 3. Coordinate the work with other trades to provide walls suitable for installation of flush-mounted panelboards where indicated.
  - 4. Verify with manufacturer that conductor terminations are suitable for use with the conductors to be installed.
  - 5. Notify Architect of any conflicts with or deviations from Contract Documents. Obtain direction before proceeding with work.

#### **1.05 SUBMITTALS**

- A. See Section 013000 - Administrative Requirements, for submittal procedures.

- B. Product Data: Provide manufacturer's standard catalog pages and data sheets for panelboards, enclosures, overcurrent protective devices, and other installed components and accessories.

#### **1.06 QUALITY ASSURANCE**

- A. Comply with requirements of NFPA 70.

#### **1.07 DELIVERY, STORAGE, AND HANDLING**

- A. Receive, inspect, handle, and store panelboards in accordance with manufacturer's instructions and NECA 407.
- B. Store in a clean, dry space. Maintain factory wrapping or provide an additional heavy canvas or heavy plastic cover to protect units from dirt, water, construction debris, and traffic.
- C. Handle carefully in accordance with manufacturer's written instructions to avoid damage to panelboard internal components, enclosure, and finish.

#### **1.08 FIELD CONDITIONS**

- A. Maintain ambient temperature within the following limits during and after installation of panelboards:
  - 1. Panelboards Containing Circuit Breakers: Between 23 degrees F (-5 degrees C) and 104 degrees F (40 degrees C).

### **PART 2 PRODUCTS**

#### **2.01 PANELBOARDS - GENERAL REQUIREMENTS**

- A. Provide products listed, classified, and labeled as suitable for the purpose intended.
- B. Unless otherwise indicated, provide products suitable for continuous operation under the following service conditions:
  - 1. Altitude: Less than 6,600 feet (2,000 m).
  - 2. Ambient Temperature:
    - a. Panelboards Containing Circuit Breakers: Between 23 degrees F (-5 degrees C) and 104 degrees F (40 degrees C).
- C. Short Circuit Current Rating:
- D. Mains: Configure for top or bottom incoming feed as indicated or as required for the installation.
- E. Branch Overcurrent Protective Devices: Replaceable without disturbing adjacent devices.
- F. Bussing: Sized in accordance with UL 67 temperature rise requirements.
  - 1. Provide solidly bonded equipment ground bus in each panelboard, with a suitable lug for each feeder and branch circuit equipment grounding conductor.
- G. Conductor Terminations: Suitable for use with the conductors to be installed.
- H. Enclosures: Comply with NEMA 250, and list and label as complying with UL 50 and UL 50E.
  - 1. Environment Type per NEMA 250: Unless otherwise indicated, as specified for the following installation locations:
  - 2. Boxes: Galvanized steel unless otherwise indicated.
    - a. Provide wiring gutters sized to accommodate the conductors to be installed.
  - 3. Fronts:
    - a. Fronts for Surface-Mounted Enclosures: Same dimensions as boxes.
    - b. Fronts for Flush-Mounted Enclosures: Overlap boxes on all sides to conceal rough opening.
  - 4. Lockable Doors: All locks keyed alike unless otherwise indicated.
- I. Future Provisions: Prepare all unused spaces for future installation of devices including bussing, connectors, mounting hardware and all other required provisions.
- J. Surge Protective Devices: Where factory-installed, internally mounted surge protective devices are provided in accordance with Section 264300, list and label panelboards as a complete assembly including surge protective device.

## **2.02 LIGHTING AND APPLIANCE PANELBOARDS**

- A. Description: Panelboards complying with NEMA PB 1, lighting and appliance branch circuit type, circuit breaker type, and listed and labeled as complying with UL 67; ratings, configurations and features as indicated on the drawings.
- B. Conductor Terminations:
  - 1. Main and Neutral Lug Material: Aluminum, suitable for terminating aluminum or copper conductors.
  - 2. Main and Neutral Lug Type: Mechanical.
- C. Bussing:
  - 1. Phase Bus Connections: Arranged for sequential phasing of overcurrent protective devices.
  - 2. Phase and Neutral Bus Material: Aluminum.
  - 3. Ground Bus Material: Aluminum.
- D. Circuit Breakers: Thermal magnetic bolt-on type unless otherwise indicated.
- E. Enclosures:
  - 1. Provide surface-mounted or flush-mounted enclosures as indicated.
  - 2. Provide clear plastic circuit directory holder mounted on inside of door.

## **2.03 LOAD CENTERS**

- A. Description: Circuit breaker type load centers listed and labeled as complying with UL 67; ratings, configurations, and features as indicated on the drawings.
- B. Bussing:
  - 1. Phase Bus Connections: Arranged for sequential phasing of overcurrent protective devices.
  - 2. Bus Material: Aluminum or copper.
- C. Circuit Breakers: Thermal magnetic plug-in type.
- D. Enclosures:
  - 1. Provide flush-mounted enclosures unless otherwise indicated.
  - 2. Provide circuit directory label on inside of door or individual circuit labels adjacent to circuit breakers.

## **2.04 OVERCURRENT PROTECTIVE DEVICES**

- A. Molded Case Circuit Breakers:
  - 1. Description: Quick-make, quick-break, over center toggle, trip-free, trip-indicating circuit breakers listed and labeled as complying with UL 489, and complying with FS W-C-375 where applicable; ratings, configurations, and features as indicated on the drawings.
  - 2. Interrupting Capacity:
    - a. Provide circuit breakers with interrupting capacity as required to provide the short circuit current rating indicated, but not less than:
    - b. Fully Rated Systems: Provide circuit breakers with interrupting capacity not less than the short circuit current rating indicated.
  - 3. Conductor Terminations:
    - a. Lug Material: Aluminum, suitable for terminating aluminum or copper conductors.
  - 4. Thermal Magnetic Circuit Breakers: For each pole, furnish thermal inverse time tripping element for overload protection and magnetic instantaneous tripping element for short circuit protection.
  - 5. Multi-Pole Circuit Breakers: Furnish with common trip for all poles.

## **2.05 SOURCE QUALITY CONTROL**

- A. Factory test panelboards according to NEMA PB 1.

## **PART 3 EXECUTION**

### **3.01 EXAMINATION**

- A. Verify that field measurements are as indicated.
- B. Verify that the ratings and configurations of the panelboards and associated components are consistent with the indicated requirements.
- C. Verify that mounting surfaces are ready to receive panelboards.
- D. Verify that conditions are satisfactory for installation prior to starting work.

### **3.02 INSTALLATION**

- A. Perform work in accordance with NECA 1 (general workmanship).
- B. Install products in accordance with manufacturer's instructions.
- C. Install panelboards in accordance with NECA 407 and NEMA PB 1.1.
- D. Arrange equipment to provide minimum clearances in accordance with manufacturer's instructions and NFPA 70.
- E. Provide required support and attachment in accordance with Section 260529.
- F. Install panelboards plumb.
- G. Install flush-mounted panelboards so that trims fit completely flush to wall with no gaps and rough opening completely covered.
- H. Mount panelboards such that the highest position of any operating handle for circuit breakers or switches does not exceed 79 inches (2000 mm) above the floor or working platform.
- I. Provide minimum of six spare 1 inch (27 mm) trade size conduits out of each flush-mounted panelboard stubbed into accessible space above ceiling and below floor.
- J. Provide grounding and bonding in accordance with Section 260526.
- K. Install all field-installed branch devices, components, and accessories.
- L. Provide filler plates to cover unused spaces in panelboards.

### **3.03 ADJUSTING**

- A. Adjust tightness of mechanical and electrical connections to manufacturer's recommended torque settings.
- B. Adjust alignment of panelboard fronts.

### **3.04 CLEANING**

- A. Clean dirt and debris from panelboard enclosures and components according to manufacturer's instructions.
- B. Repair scratched or marred exterior surfaces to match original factory finish.

**END OF SECTION**



**SECTION 262726  
WIRING DEVICES - LUTRON**

**PART 1 GENERAL**

**1.01 SECTION INCLUDES**

- A. Mechanical wall switches.
- B. Wall dimmers and electronic switches.
- C. Receptacles.
- D. Wall plates.

**1.02 RELATED REQUIREMENTS**

- A. Section 260526 - Grounding and Bonding for Electrical Systems.
- B. Section 260533.16 - Boxes for Electrical Systems.
- C. Section 260553 - Identification for Electrical Systems: Identification products and requirements.

**1.03 REFERENCE STANDARDS**

- A. ASTM D4674 - Standard Practice for Accelerated Testing for Color Stability of Plastics Exposed to Indoor Office Environments; 2019.
- B. ASTM E308 - Standard Practice for Computing the Colors of Objects by Using the CIE System; 2022.
- C. IEC 61000-4-2 - Electromagnetic Compatibility (EMC) - Part 4-2: Testing and Measurement Techniques - Electrostatic Discharge Immunity Test; 2008.
- D. IEEE C62.41.2 - IEEE Recommended Practice on Characterization of Surges in Low-Voltage (1000 V and less) AC Power Circuits; 2002 (Corrigendum 2012).
- E. ISO 9001 - Quality Management Systems — Requirements; 2015.
- F. NECA 1 - Standard for Good Workmanship in Electrical Construction; 2015.
- G. NECA 130 - Standard for Installing and Maintaining Wiring Devices; 2016.
- H. NEMA WD 1 - General Color Requirements for Wiring Devices; 1999 (Reaffirmed 2020).
- I. NEMA WD 6 - Wiring Devices - Dimensional Specifications; 2021.
- J. NFPA 70 - National Electrical Code; Most Recent Edition Adopted by Authority Having Jurisdiction, Including All Applicable Amendments and Supplements.
- K. UL 20 - General-Use Snap Switches; Current Edition, Including All Revisions.
- L. UL 498 - Attachment Plugs and Receptacles; Current Edition, Including All Revisions.
- M. UL 508 - Industrial Control Equipment; Current Edition, Including All Revisions.
- N. UL 514C - Nonmetallic Outlet Boxes, Flush-Device Boxes, and Covers; Current Edition, Including All Revisions.
- O. UL 943 - Ground-Fault Circuit-Interrupters; Current Edition, Including All Revisions.
- P. UL 1472 - Solid-State Dimming Controls; Current Edition, Including All Revisions.

**1.04 ADMINISTRATIVE REQUIREMENTS**

- A. Coordination:
  - 1. Coordinate the placement of wiring devices with millwork, furniture, equipment, etc. installed under other sections or by others.
  - 2. Coordinate wiring device ratings and configurations with the electrical requirements of actual equipment to be installed.
  - 3. Coordinate the placement of wall controls with actual installed door swings.
  - 4. Notify Architect of any conflicts or deviations from the contract documents to obtain direction prior to proceeding with work.
- B. Sequencing:

1. Do not install wiring devices until final surface finishes and painting are complete.

#### **1.05 SUBMITTALS**

- A. See Section 013000 - Administrative Requirements for submittal procedures.
- B. Product Data: Provide manufacturer's catalog information showing dimensions, colors, and configurations.
  1. Wall Dimmers: Include derating information for ganged multiple devices.

#### **1.06 QUALITY ASSURANCE**

- A. Conform to requirements of NFPA 70.
- B. Manufacturer Qualifications:
  1. Company with not less than ten years of experience manufacturing lighting controls, including products using wireless communication between devices.
  2. Registered to ISO 9001, including in-house engineering for product design activities.
  3. Provides factory direct technical support hotline available 24 hours per day, 7 days per week.
  4. Qualified to supply specified products and to honor claims against product presented in accordance with warranty.

#### **1.07 DELIVERY, STORAGE, AND PROTECTION**

- A. Store products in a clean, dry space in original manufacturer's packaging in accordance with manufacturer's written instructions until ready for installation.

#### **1.08 FIELD CONDITIONS**

- A. Maintain field conditions within manufacturer's required service conditions during and after installation.
  1. Basis of Design System Requirements - Lutron, Unless Otherwise Indicated:
    - a. Ambient Temperature:
      - 1) Lighting Controls: Between 32 and 104 degrees F (0 and 40 degrees C).
    - b. Relative Humidity: Less than 90 percent, non-condensing.
    - c. Protect lighting controls from dust.

#### **1.09 WARRANTY**

- A. See Section 017800 - Closeout Submittals, for additional warranty requirements.
- B. Wallbox Dimmers, Switches, and Fan Speed Controllers: One year 100 percent parts coverage, no manufacturer labor coverage.

### **PART 2 PRODUCTS**

#### **2.01 MANUFACTURERS**

- A. Basis of Design Manufacturer: Lutron Electronics Company, Inc: [www.lutron.com/#sle](http://www.lutron.com/#sle).

#### **2.02 WIRING DEVICES - GENERAL REQUIREMENTS**

- A. Provide products listed and classified by Underwriters Laboratories Inc. as suitable for the purpose specified and indicated.
- B. Provide wiring devices suitable for intended use and with ratings adequate for load served.
- C. Unless specifically indicated to be excluded, provide all required equipment, conduit, boxes, wiring, connectors, hardware, supports, accessories, programming, etc. as necessary for a complete operating system that provides the control intent indicated.
- D. Design lighting control equipment for 10 year operational life while operating continually at any temperature in an ambient temperature range of 32 degrees F (0 degrees C) to 104 degrees F (40 degrees C) and 90 percent non-condensing relative humidity.
- E. Electrostatic Discharge Tolerance: Design and test equipment to withstand electrostatic discharges without impairment when tested according to IEC 61000-4-2.
- F. Power Failure Recovery: When power is interrupted for periods up to 10 years and subsequently restored, lights to automatically return to same levels (dimmed setting, full on, or

full off) as prior to power interruption.

G. Device Finishes:

1. Standard Colors: Comply with NEMA WD 1 where applicable.
2. Color Variation in Same Product Family: Maximum delta E of 1, CIE L\*a\*b color units per ASTM E308.
3. Visible Parts: Exhibit ultraviolet color stability when tested with multiple actinic light sources as defined in ASTM D4674. Provide proof of testing upon request.

## 2.03 MECHANICAL WALL SWITCHES

- A. Comply with NEMA WD 6, where applicable, and list as complying with UL 20.

## 2.04 WALL DIMMERS AND ELECTRONIC SWITCHES

A. General Requirements:

1. Utilize air gap off, activated when user selects "off" to disconnect the load from line supply.
2. Provide air gap service switch accessible without removing faceplate.
3. Operates at the rated capacity across the full ambient temperature range including modified capacities for ganged configurations which require removal of fins.
4. Provide radio frequency interference suppression.
5. Surge Tolerance: Designed and tested to withstand surges of 6,000 V, 200 amps according to IEEE C62.41.2 without impairment to performance.
6. Dimmers: Provide full range, continuously variable control of light intensity.
7. Dimmers for Electronic Low Voltage (ELV) Transformers:
  - a. Provide circuitry designed to control the input of electronic (solid-state) low voltage (ELV) transformers. Do not use dimmers that utilize standard phase control.
  - b. Provide resettable overload protection that provides automatic shut-off when dimmer capacity is exceeded. Do not use protection methods that are non-resettable or require device to be removed from outlet box.
  - c. Designed to withstand a short, per UL 1472, between load hot and either neutral or ground without damage to dimmer.
8. Dimmers for Magnetic Low Voltage (MLV) Transformers:
  - a. Provide circuitry designed to control and provide a symmetrical AC waveform to input of magnetic low voltage transformers per UL 1472.
  - b. Magnetic low voltage transformers to operate below rated current or temperature.
9. Fluorescent Dimmers:
  - a. Provides direct control of fluorescent dimming ballasts up to the ballast manufacturer's specified rating.
10. Electronic Switches:
  - a. Listed as complying with UL 20, UL 508, and UL 1472.

## 2.05 RECEPTACLES

- A. Comply with NEMA WD 6, and list as complying with UL 498.
- B. NEMA configurations specified are according to NEMA WD 6.
- C. GFCI Receptacles: Provide with feed-through protection, light to indicate ground fault tripped condition and loss of protection, and with test and reset buttons of same color as device; list as complying with UL 943, class A.

## 2.06 WALL PLATES

- A. Manufacturer: Same as manufacturer of devices, for aesthetically compatible installation.
- B. Provide screwless wall plates with concealed mounting hardware and alignment adapter plate, suitable for the quantity and types of devices to be installed.
- C. List as complying with UL 514C.

## PART 3 EXECUTION

### 3.01 EXAMINATION

- A. Verify that field measurements are as shown on the drawings.

- B. Verify that ratings and configurations of devices are consistent with the indicated requirements.
- C. Verify that mounting surfaces are ready to receive devices.
- D. Verify that conditions are satisfactory for installation prior to starting work.

### **3.02 PREPARATION**

- A. Clean dirt, debris, plaster, and other foreign materials from outlet boxes.

### **3.03 INSTALLATION**

- A. Perform work in a neat and workmanlike manner in accordance with NECA 1 and, where applicable, NECA 130, except for mounting heights specified in those standards.
- B. Coordinate locations of outlet boxes provided under Section 260533.16 as required for installation of devices provided under this section.
- C. Where multiple devices are installed at the same location and at the same mounting height, gang devices together under a common wall plate.
- D. Install products in accordance with manufacturer's instructions.
- E. Install permanent barrier between ganged devices when voltage between adjacent devices exceeds 300 V.
- F. For isolated ground receptacles, connect grounding terminal only to identified branch circuit isolated equipment grounding conductor. Do not connect grounding terminal to outlet box or normal branch circuit equipment grounding conductor.
- G. Install wall dimmers to achieve full rating specified after derating for ganging as instructed by manufacturer.
- H. Install wall plates to fit completely flush to wall with no gaps and rough opening completely covered without strain on wall plate. Repair or reinstall improperly installed outlet boxes or improperly sized rough openings.
- I. Identify devices in accordance with Section 260553.

### **3.04 FIELD QUALITY CONTROL**

- A. See Section 014000 - Quality Requirements, for additional requirements.
- B. Test each receptacle to verify operation and proper polarity.
- C. Test each GFCI receptacle for proper tripping operation according to manufacturer's instructions.
- D. Correct defective work, adjust for proper operation, and retest until entire system complies with contract documents.

### **3.05 CLEANING**

- A. Clean exposed surfaces to remove dirt, paint, or other foreign material and restore to match original factory finish.

### **3.06 PROTECTION**

- A. Protect installed products from subsequent construction operations.

**END OF SECTION**

**SECTION 265100  
INTERIOR LIGHTING**

**PART 1 GENERAL**

**1.01 SECTION INCLUDES**

- A. Interior luminaires.
- B. Emergency lighting units.
- C. Exit signs.

**1.02 RELATED REQUIREMENTS**

- A. Section 260529 - Hangers and Supports for Electrical Systems.
- B. Section 260533.16 - Boxes for Electrical Systems.
- C. Section 260553 - Identification for Electrical Systems: Identification products and requirements.
- D. Section 262726 - Wiring Devices: Manual wall switches and wall dimmers.
- E. Section 265600 - Exterior Lighting.

**1.03 REFERENCE STANDARDS**

- A. NECA/IESNA 500 - Standard for Installing Indoor Lighting Systems; 2006.
- B. NECA/IESNA 502 - Standard for Installing Industrial Lighting Systems; 2006.
- C. NFPA 70 - National Electrical Code; Most Recent Edition Adopted by Authority Having Jurisdiction, Including All Applicable Amendments and Supplements.
- D. NFPA 101 - Life Safety Code; Most Recent Edition Adopted by Authority Having Jurisdiction, Including All Applicable Amendments and Supplements.
- E. UL 924 - Emergency Lighting and Power Equipment; Current Edition, Including All Revisions.
- F. UL 1598 - Luminaires; Current Edition, Including All Revisions.

**1.04 ADMINISTRATIVE REQUIREMENTS**

- A. Coordination:
  - 1. Coordinate the installation of luminaires with mounting surfaces installed under other sections or by others. Coordinate the work with placement of supports, anchors, etc. required for mounting. Coordinate compatibility of luminaires and associated trims with mounting surfaces at installed locations.
  - 2. Coordinate the placement of luminaires with structural members, ductwork, piping, equipment, diffusers, fire suppression system components, and other potential conflicts installed under other sections or by others.
  - 3. Coordinate the placement of exit signs with furniture, equipment, signage or other potential obstructions to visibility installed under other sections or by others.
  - 4. Notify Architect of any conflicts or deviations from Contract Documents to obtain direction prior to proceeding with work.

**1.05 QUALITY ASSURANCE**

- A. Comply with requirements of NFPA 70.
- B. Manufacturer Qualifications: Company specializing in manufacturing the products specified in this section with minimum three years documented experience.

**1.06 DELIVERY, STORAGE, AND PROTECTION**

- A. Receive, handle, and store products according to NECA/IESNA 500 (commercial lighting), NECA/IESNA 502 (industrial lighting), and manufacturer's written instructions.
- B. Keep products in original manufacturer's packaging and protect from damage until ready for installation.

### **1.07 FIELD CONDITIONS**

- A. Maintain field conditions within manufacturer's required service conditions during and after installation.

### **1.08 WARRANTY**

- A. See Section 017800 - Closeout Submittals, for additional warranty requirements.
- B. Provide 3-year manufacturer warranty for LED luminaires, including drivers.

## **PART 2 PRODUCTS**

### **2.01 LUMINAIRE TYPES**

- A. Furnish products as indicated in luminaire schedule included on the drawings.

### **2.02 LUMINAIRES**

- A. Provide products that comply with requirements of NFPA 70.
- B. Provide products that are listed and labeled as complying with UL 1598, where applicable.
- C. Provide products listed, classified, and labeled as suitable for the purpose intended.
- D. Unless otherwise indicated, provide complete luminaires including lamp(s) and all sockets, ballasts, reflectors, lenses, housings and other components required to position, energize and protect the lamp and distribute the light.
- E. Unless specifically indicated to be excluded, provide all required conduit, boxes, wiring, connectors, hardware, supports, trims, accessories, etc. as necessary for a complete operating system.
- F. Provide products suitable to withstand normal handling, installation, and service without any damage, distortion, corrosion, fading, discoloring, etc.

### **2.03 EMERGENCY LIGHTING UNITS**

- A. Description: Emergency lighting units complying with NFPA 101 and all applicable state and local codes, and listed and labeled as complying with UL 924.
- B. Operation: Upon interruption of normal power source or brownout condition exceeding 20 percent voltage drop from nominal, solid-state control automatically switches connected lamps to integral battery power for minimum of 90 minutes of rated emergency illumination, and automatically recharges battery upon restoration of normal power source.
- C. Battery:
  - 1. Size battery to supply all connected lamps, including emergency remote heads where indicated.
- D. Diagnostics: Provide power status indicator light and accessible integral test switch to manually activate emergency operation.
- E. Provide low-voltage disconnect to prevent battery damage from deep discharge.

### **2.04 EXIT SIGNS**

- A. Description: Exit signs complying with NFPA 101 and applicable state and local codes, and listed and labeled as complying with UL 924.
  - 1. Number of Faces: Single- or double-face as indicated or as required for installed location.
  - 2. Directional Arrows: As indicated or as required for installed location.
- B. Powered Exit Signs: Internally illuminated with LEDs unless otherwise indicated.

## **PART 3 EXECUTION**

### **3.01 EXAMINATION**

- A. Verify that field measurements are as indicated.
- B. Verify that outlet boxes are installed in proper locations and at proper mounting heights and are properly sized to accommodate conductors in accordance with NFPA 70.
- C. Verify that suitable support frames are installed where required.

- D. Verify that branch circuit wiring installation is completed, tested, and ready for connection to luminaires.
- E. Verify that conditions are satisfactory for installation prior to starting work.

### **3.02 PREPARATION**

- A. Provide extension rings to bring outlet boxes flush with finished surface.
- B. Clean dirt, debris, plaster, and other foreign materials from outlet boxes.

### **3.03 INSTALLATION**

- A. Coordinate locations of outlet boxes provided under Section 260533.16 as required for installation of luminaires provided under this section.
- B. Install products in accordance with manufacturer's instructions.
- C. Install luminaires securely, in a neat and workmanlike manner, as specified in NECA 500 (commercial lighting) and NECA 502 (industrial lighting).
- D. Provide required support and attachment in accordance with Section 260529.
- E. Install luminaires plumb and square and aligned with building lines and with adjacent luminaires.
- F. Install accessories furnished with each luminaire.
- G. Bond products and metal accessories to branch circuit equipment grounding conductor.
- H. Emergency Lighting Units:
- I. Exit Signs:
- J. Install lamps in each luminaire.

### **3.04 FIELD QUALITY CONTROL**

- A. See Section 014000 - Quality Requirements, for additional requirements.
- B. Inspect each product for damage and defects.
- C. Operate each luminaire after installation and connection to verify proper operation.
- D. Test self-powered exit signs, emergency lighting units, and fluorescent emergency power supply units to verify proper operation upon loss of normal power supply.
- E. Correct wiring deficiencies and repair or replace damaged or defective products. Repair or replace excessively noisy ballasts as determined by Architect.

### **3.05 ADJUSTING**

- A. Aim and position adjustable luminaires to achieve desired illumination as indicated or as directed by Architect. Secure locking fittings in place.
- B. Aim and position adjustable emergency lighting unit lamps to achieve optimum illumination of egress path as required or as directed by Architect or authority having jurisdiction.
- C. Exit Signs with Field-Selectable Directional Arrows: Set as indicated or as required to properly designate egress path as directed by Architect or authority having jurisdiction.

### **3.06 CLEANING**

- A. Clean surfaces according to NECA 500 (commercial lighting), NECA 502 (industrial lighting), and manufacturer's instructions to remove dirt, fingerprints, paint, or other foreign material and restore finishes to match original factory finish.

### **3.07 PROTECTION**

- A. Protect installed luminaires from subsequent construction operations.

**END OF SECTION**

**SECTION 265600  
EXTERIOR LIGHTING**

**PART 1 GENERAL**

**1.01 SECTION INCLUDES**

- A. Exterior luminaires.
- B. Poles and accessories.
- C. Luminaire accessories.

**1.02 RELATED REQUIREMENTS**

- A. Section 260526 - Grounding and Bonding for Electrical Systems.
- B. Section 260529 - Hangers and Supports for Electrical Systems.
- C. Section 260533.16 - Boxes for Electrical Systems.
- D. Section 260923 - Lighting Control Devices.
- E. Section 262726 - Wiring Devices: Receptacles for installation in poles.
- F. Section 265100 - Interior Lighting.

**1.03 REFERENCE STANDARDS**

- A. NECA 1 - Standard for Good Workmanship in Electrical Construction; 2015.
- B. NECA/IESNA 501 - Standard for Installing Exterior Lighting Systems; 2000 (Reaffirmed 2006).
- C. NFPA 70 - National Electrical Code; Most Recent Edition Adopted by Authority Having Jurisdiction, Including All Applicable Amendments and Supplements.
- D. UL 1598 - Luminaires; Current Edition, Including All Revisions.

**1.04 ADMINISTRATIVE REQUIREMENTS**

**1.05 SUBMITTALS**

- A. See Section 013000 - Administrative Requirements, for submittal procedures.
- B. Product Data: Provide manufacturer's standard catalog pages and data sheets including detailed information on luminaire construction, dimensions, ratings, finishes, mounting requirements, listings, service conditions, photometric performance, weight, effective projected area (EPA), and installed accessories; include model number nomenclature clearly marked with all proposed features.
- C. Certificates for Poles and Accessories: Manufacturer's documentation that products are suitable for the luminaires to be installed and comply with designated structural design criteria.

**1.06 QUALITY ASSURANCE**

- A. Comply with requirements of NFPA 70.

**1.07 DELIVERY, STORAGE, AND HANDLING**

- A. Receive, handle, and store products according to NECA/IESNA 501 and manufacturer's written instructions.
- B. Keep products in original manufacturer's packaging and protect from damage until ready for installation.

**1.08 WARRANTY**

- A. See Section 017800 - Closeout Submittals, for additional warranty requirements.
- B. Provide 3-year manufacturer warranty for LED replacement lamps.

**PART 2 PRODUCTS**

**2.01 LUMINAIRE TYPES**

- A. Furnish products as indicated in luminaire schedule included on the drawings.



## **2.02 LUMINAIRES**

- A. Provide products that comply with requirements of NFPA 70.
- B. Provide products that are listed and labeled as complying with UL 1598, where applicable.
- C. Provide products listed, classified, and labeled as suitable for the purpose intended.
- D. Unless otherwise indicated, provide complete luminaires including lamp(s) and all sockets, ballasts, reflectors, lenses, housings and other components required to position, energize and protect the lamp and distribute the light.
- E. Unless specifically indicated to be excluded, provide all required conduit, boxes, wiring, connectors, hardware, poles, foundations, supports, trims, accessories, etc. as necessary for a complete operating system.
- F. Provide products suitable to withstand normal handling, installation, and service without any damage, distortion, corrosion, fading, discoloring, etc.

## **2.03 POLES**

- A. All Poles:
  - 1. Provide poles and associated support components suitable for the luminaire(s) and associated supports and accessories to be installed.
  - 2. Material: Steel, unless otherwise indicated.
  - 3. Shape: Square straight, unless otherwise indicated.
  - 4. Finish: Match luminaire finish, unless otherwise indicated.

## **2.04 ACCESSORIES**

### **PART 3 EXECUTION**

#### **3.01 PREPARATION**

- A. Provide extension rings to bring outlet boxes flush with finished surface.
- B. Clean dirt, debris, plaster, and other foreign materials from outlet boxes.

#### **3.02 INSTALLATION**

- A. Coordinate locations of outlet boxes provided under Section 260533.16 as required for installation of luminaires provided under this section.
- B. Install products in accordance with manufacturer's instructions.
- C. Install luminaires in accordance with NECA/IESNA 501.
- D. Provide required support and attachment in accordance with Section 260529.
- E. Install luminaires plumb and square and aligned with building lines and with adjacent luminaires.
- F. Install accessories furnished with each luminaire.
- G. Bond products and metal accessories to branch circuit equipment grounding conductor.
- H. Install lamps in each luminaire.

#### **3.03 FIELD QUALITY CONTROL**

- A. See Section 014000 - Quality Requirements, for additional requirements.
- B. Inspect each product for damage and defects.
- C. Operate each luminaire after installation and connection to verify proper operation.
- D. Correct wiring deficiencies and repair or replace damaged or defective products. Repair or replace excessively noisy ballasts as determined by Architect.

#### **3.04 ADJUSTING**

- A. Aim and position adjustable luminaires to achieve desired illumination as indicated or as directed by Architect. Secure locking fittings in place.

**3.05 CLEANING**

- A. Clean surfaces according to NECA/IESNA 501 and manufacturer's instructions to remove dirt, fingerprints, paint, or other foreign material and restore finishes to match original factory finish.

**3.06 PROTECTION**

- A. Protect installed luminaires from subsequent construction operations.

**END OF SECTION**

## **SECTION 271000 STRUCTURED CABLING**

### **PART 1 GENERAL**

#### **1.01 SECTION INCLUDES**

- A. Communications system design requirements.
- B. Communications pathways.
- C. Copper cable and terminations.
- D. Communications outlets.
- E. Communications grounding and bonding.
- F. Communications identification.

#### **1.02 RELATED REQUIREMENTS**

- A. Section 260526 - Grounding and Bonding for Electrical Systems.
- B. Section 260533.16 - Boxes for Electrical Systems.
- C. Section 260553 - Identification for Electrical Systems: Identification products.
- D. Section 262726 - Wiring Devices.

#### **1.03 REFERENCE STANDARDS**

- A. BICSI N1 - Installation Practices for Telecommunications and ICT Cabling and Related Cabling Infrastructure, 1st Edition; 2019.
- B. ICEA S-90-661 - Category 3 and 5E Individually Unshielded Twisted Pairs, Indoor Cables (With or Without an Overall Shield) for Use in General Purpose and LAN Communication Wiring Systems; 2021.
- C. NFPA 70 - National Electrical Code; Most Recent Edition Adopted by Authority Having Jurisdiction, Including All Applicable Amendments and Supplements.
- D. TIA-568 (SET) - Commercial Building Telecommunications Cabling Standard Set; 2020.
- E. TIA-568.2 - Balanced Twisted-Pair Telecommunications Cabling and Components Standards; 2018d, with Addenda (2020).
- F. TIA-569 - Telecommunications Pathways and Spaces; 2019e, with Addendum (2022).
- G. TIA-606 - Administration Standard for Telecommunications Infrastructure; 2021d.
- H. TIA-607 - Generic Telecommunications Bonding and Grounding (Earthing) for Customer Premises; 2019d, with Addendum (2021).
- I. UL 444 - Communications Cables; Current Edition, Including All Revisions.
- J. UL 514C - Nonmetallic Outlet Boxes, Flush-Device Boxes, and Covers; Current Edition, Including All Revisions.
- K. UL 1863 - Communications-Circuit Accessories; Current Edition, Including All Revisions.

#### **1.04 ADMINISTRATIVE REQUIREMENTS**

- A. Coordination:
  - 1. Coordinate requirements for service entrance and entrance facilities with Communications Service Provider.
  - 2. Coordinate the work with other trades to avoid placement of other utilities or obstructions within the spaces dedicated for communications equipment.
  - 3. Coordinate arrangement of communications equipment with the dimensions and clearance requirements of the actual equipment to be installed.
  - 4. Notify Architect of any conflicts with or deviations from Contract Documents. Obtain direction before proceeding with work.

#### **1.05 SUBMITTALS**

- A. See Section 013000 - Administrative Requirements, for submittal procedures.

- B. Product Data: Provide manufacturer's standard catalog pages and data sheets for each product.
- C. Shop Drawings: Show compliance with requirements on isometric schematic diagram of network layout, showing cable routings, telecommunication closets, rack and enclosure layouts and locations, service entrance, and grounding, prepared and approved by BICSI Registered Communications Distribution Designer (RCDD).
- D. Field Test Reports.

## **1.06 QUALITY ASSURANCE**

### **1.07 DELIVERY, STORAGE, AND HANDLING**

- A. Store products in manufacturer's unopened packaging until ready for installation.
- B. Keep stored products clean and dry.

## **PART 2 PRODUCTS**

### **2.01 SYSTEM DESIGN**

- A. Provide a complete permanent system of cabling and pathways for voice and data communications, including cables, conduits and wireways, pull wires, support structures, enclosures and cabinets, and outlets.
  - 1. Provide fixed cables and pathways that comply with NFPA 70 and TIA-607 and are UL listed or third party independent testing laboratory certified.
  - 2. Provide connection devices that are rated for operation under conditions of 32 to 140 degrees F (0 to 60 degrees C) at relative humidity of 0 to 95 percent, noncondensing.
  - 3. In this project, the term plenum is defined as return air spaces above ceilings, inside ducts, under raised floors, and other air-handling spaces.
- B. Main Distribution Frame (MDF): Centrally located support structure for terminating horizontal cables that extend to telecommunications outlets, functioning as point of presence to external service provider.
  - 1. Locate main distribution frame as indicated on the drawings.
- C. Cabling to Outlets: Specified horizontal cabling, wired in star topology to distribution frame located at center hub of star; also referred to as "links".

### **2.02 COPPER CABLE AND TERMINATIONS**

- A. Copper Backbone Cable:
  - 1. Description: 100 ohm, balanced twisted pair cable complying with TIA-568.2, ICEA S-90-661, and listed and labeled as complying with UL 444; arranged in 25-pair binder groups.
  - 2. Cable Type: TIA-568.2 Category 3 UTP (unshielded twisted pair); 24 AWG.
  - 3. Cable Capacity: Quantity of pairs as indicated on drawings.
  - 4. Cable Applications:
    - a. Plenum Applications: Use listed NFPA 70 Type CMP plenum cable.
    - b. Riser Applications: Use listed NFPA 70 Type CMR riser cable or Type CMP plenum cable.
- B. Copper Horizontal Cable:
  - 1. Description: 100 ohm, balanced twisted pair cable complying with TIA-568.2 and listed and labeled as complying with UL 444.
  - 2. Cable Type - Voice and Data: TIA-568.2 Category 6 UTP (unshielded twisted pair); 23 AWG.
  - 3. Cable Capacity: 4-pair.
  - 4. Cable Applications: Use listed NFPA 70 Type CMP plenum cable unless otherwise indicated.
- C. Copper Cable Terminations: Insulation displacement connection (IDC) type using appropriate tool; use screw connections only where specifically indicated.

- D. Jacks and Connectors: Modular RJ-45, non-keyed, terminated with 110-style insulation displacement connectors (IDC); high impact thermoplastic housing; suitable for and complying with same standard as specified horizontal cable; UL 1863 listed.
  - 1. Performance: 500 mating cycles.
  - 2. Voice and Data Jacks: 8-position modular jack, color-coded for both T568A and T568B wiring configurations.

### **2.03 COMMUNICATIONS OUTLETS**

- A. Outlet Boxes: Comply with Section 260533.16.
  - 1. Provide depth as required to accommodate cable manufacturer's recommended minimum conductor bend radius.
- B. Wall Plates:
  - 1. Comply with system design standards and UL 514C.
  - 2. Accepts modular jacks/inserts.
  - 3. Capacity:
    - a. Data or Combination Voice/Data Outlets: \_\_\_\_\_.
  - 4. Wall Plate Material/Finish - Flush-Mounted Outlets: Match wiring device and wall plate finishes specified in Section 262726.

### **2.04 GROUNDING AND BONDING COMPONENTS**

- A. Comply with TIA-607.

### **2.05 IDENTIFICATION PRODUCTS**

- A. Comply with TIA-606.

## **PART 3 EXECUTION**

### **3.01 INSTALLATION - GENERAL**

- A. Comply with latest editions and addenda of TIA-568 (SET) (cabling), TIA-569 (pathways), TIA-607 (grounding and bonding), BICSI N1, NFPA 70, and SYSTEM DESIGN as specified in PART 2.
- B. Comply with Communication Service Provider requirements.
- C. Grounding and Bonding: Perform in accordance with TIA-607 and NFPA 70.

### **3.02 INSTALLATION OF PATHWAYS**

- A. Install pathways with the following minimum clearances:
  - 1. 48 inches (1220 mm) from motors, generators, frequency converters, transformers, x-ray equipment, and uninterruptible power systems.
  - 2. 12 inches (300 mm) from power conduits and cables and panelboards.
  - 3. 5 inches (125 mm) from fluorescent and high frequency lighting fixtures.
  - 4. 6 inches (150 mm) from flues, hot water pipes, and steam pipes.
- B. Outlet Boxes:
  - 1. Coordinate locations of outlet boxes provided under Section 260533.16 as required for installation of telecommunications outlets provided under this section.

### **3.03 INSTALLATION OF EQUIPMENT AND CABLING**

- A. Cabling:
  - 1. Do not bend cable at radius less than manufacturer's recommended bend radius; for unshielded twisted pair use bend radius of not less than 4 times cable diameter.
  - 2. Do not over-cinch or crush cables.
  - 3. Do not exceed manufacturer's recommended cable pull tension.
  - 4. When installing in conduit, use only lubricants approved by cable manufacturer and do not chafe or damage outer jacket.
- B. Service Loops (Slack or Excess Length): Provide the following minimum extra length of cable, looped neatly:
  - 1. At Distribution Frames: 120 inches (3000 mm).

2. At Outlets - Copper: 12 inches (305 mm).
- C. Copper Cabling:
  1. Category 5e and Above: Maintain cable geometry; do not untwist more than 1/2 inch (12 mm) from point of termination.
  2. For 4-pair cables in conduit, do not exceed 25 pounds (110 N) pull tension.
  3. Use T568B wiring configuration.
- D. Identification:
  1. Use wire and cable markers to identify cables at each end.
  2. Use manufacturer-furnished label inserts, identification labels, or engraved wallplate to identify each jack at communications outlets with unique identifier.

### **3.04 FIELD QUALITY CONTROL**

- A. See Section 014000 - Quality Requirements, for additional requirements.
- B. Comply with inspection and testing requirements of specified installation standards.
- C. Visual Inspection:
  1. Inspect cable jackets for certification markings.
  2. Inspect cable terminations for color coded labels of proper type.
  3. Inspect outlet plates and patch panels for complete labels.
- D. Testing - Copper Cabling and Associated Equipment:
  1. Test backbone cables after termination but before cross-connection.
  2. Test backbone cables for DC loop resistance, shorts, opens, intermittent faults, and polarity between connectors and between conductors and shield, if cable has overall shield.
  3. Category 3 Backbone: Perform attenuation test.
  4. Category 3 Links: Test each pair for short circuit continuity, short to ground, crosses, reversed polarity, operational and ring-back, and dial tone.
  5. Category 5e and Above Backbone: Perform near end cross talk (NEXT) and attenuation tests.
  6. Category 5e and Above Links: Perform tests for wire map, length, attenuation, NEXT, and propagation delay.
- E. Final Testing: After all work is complete, including installation of telecommunications outlets, and telephone dial tone service is active, test each voice jack for dial tone.

**END OF SECTION**

**SECTION 282000  
VIDEO SURVEILLANCE**

**PART 1 GENERAL**

**1.01 SECTION INCLUDES**

- A. Video surveillance system requirements.

**1.02 RELATED REQUIREMENTS**

- A. Section 260526 - Grounding and Bonding for Electrical Systems.
- B. Section 260529 - Hangers and Supports for Electrical Systems.
- C. Section 260553 - Identification for Electrical Systems: Identification products and requirements.
- D. Section 271000 - Structured Cabling: Data cables for IP video surveillance system network connections.

**1.03 REFERENCE STANDARDS**

- A. 47 CFR 15 - Radio Frequency Devices; current edition.
- B. NECA 1 - Standard for Good Workmanship in Electrical Construction; 2015.
- C. NECA 303 - Standard for Installing and Maintaining Closed-Circuit Television (CCTV) Systems; 2019.
- D. NFPA 70 - National Electrical Code; Most Recent Edition Adopted by Authority Having Jurisdiction, Including All Applicable Amendments and Supplements.

**1.04 ADMINISTRATIVE REQUIREMENTS**

- A. Coordination:
  - 1. Coordinate the placement of cameras with structural members, ductwork, piping, equipment, luminaires, diffusers, fire suppression system components, and other potential conflicts installed under other sections or by others.
  - 2. Coordinate the work with other installers to provide power for cameras and equipment at required locations.
  - 3. Notify Architect of any conflicts with or deviations from Contract Documents. Obtain direction before proceeding with work.

**1.05 SUBMITTALS**

- A. See Section 013000 - Administrative Requirements, for submittal procedures.
- B. Shop Drawings: Include plan views indicating locations of system components and proposed size, type, and routing of conduits and/or cables. Include elevations and details of proposed equipment arrangements. Include system interconnection schematic diagrams. Include requirements for interface with other systems.
- C. Product Data: Provide manufacturer's standard catalog pages and data sheets for each system component. Include ratings, configurations, standard wiring diagrams, dimensions, finishes, service condition requirements, and installed features.
- D. Operation and Maintenance Data: Include detailed information on system operation, equipment programming and setup, replacement parts, and recommended maintenance procedures and intervals.

**1.06 QUALITY ASSURANCE**

- A. Comply with the following:
  - 1. NFPA 70.
  - 2. Applicable TIA/EIA standards.
- B. Manufacturer Qualifications: Company specializing in manufacturing the products specified in this section with minimum three years documented experience.

## **PART 2 PRODUCTS**

### **2.01 VIDEO SURVEILLANCE SYSTEM**

- A. Provide new video surveillance system consisting of all required equipment, conduit, boxes, wiring, connectors, hardware, supports, accessories, software, system programming, etc. as necessary for a complete operating system that provides the functional intent indicated.
- B. System Description: IP system with connection to network (IP) cameras.
- C. Provide products listed, classified, and labeled as suitable for the purpose intended.
- D. Electromagnetic Interference/Radio Frequency Interference (EMI/RFI) Limits: Comply with FCC requirements of 47 CFR 15, for Class B, consumer application.

## **PART 3 EXECUTION**

### **3.01 EXAMINATION**

- A. Verify that field measurements are as indicated.
- B. Verify that ratings and configurations of system components are consistent with the indicated requirements.
- C. Verify that mounting surfaces are ready to receive system components.
- D. Verify that branch circuit wiring installation is completed, tested, and ready for connection to system where applicable.
- E. Verify that conditions are satisfactory for installation prior to starting work.

### **3.02 INSTALLATION**

- A. Install video surveillance system in accordance with NECA 1 (general workmanship) and NECA 303.
- B. Install products in accordance with manufacturer's instructions.
- C. Provide required support and attachment in accordance with Section 260529.
- D. Provide grounding and bonding in accordance with Section 260526.
- E. Identify system wiring and components in accordance with Section 260553.

### **3.03 FIELD QUALITY CONTROL**

- A. See Section 014000 - Quality Requirements, for additional requirements.
- B. Prepare and start system in accordance with manufacturer's instructions.
- C. Adjust cameras to provide desired field of view and produce suitable images under all service lighting conditions.
- D. Program system parameters according to requirements of Owner.
- E. Test for proper interface with other systems.
- F. Correct defective work, adjust for proper operation, and retest until entire system complies with Contract Documents.

### **3.04 CLEANING**

- A. Clean exposed surfaces to remove dirt, paint, or other foreign material and restore to match original factory finish.

### **3.05 PROTECTION**

- A. Protect installed system components from subsequent construction operations.

**END OF SECTION**



**SECTION 284600  
FIRE DETECTION AND ALARM**

**PART 1 GENERAL**

**1.01 SECTION INCLUDES**

- A. Fire alarm system design and installation, including all components, wiring, and conduit.
- B. Transmitters for communication with supervising station.

**1.02 RELATED REQUIREMENTS**

- A. Section 233300 - Air Duct Accessories: Smoke dampers monitored and controlled by fire alarm system.

**1.03 REFERENCE STANDARDS**

- A. 36 CFR 1191 - Americans with Disabilities Act (ADA) Accessibility Guidelines for Buildings and Facilities; Architectural Barriers Act (ABA) Accessibility Guidelines; current edition.
- B. ADA Standards - 2010 ADA Standards for Accessible Design; 2010.
- C. IEEE C62.41.2 - IEEE Recommended Practice on Characterization of Surges in Low-Voltage (1000 V and less) AC Power Circuits; 2002 (Corrigendum 2012).
- D. NFPA 70 - National Electrical Code; Most Recent Edition Adopted by Authority Having Jurisdiction, Including All Applicable Amendments and Supplements.
- E. NFPA 72 - National Fire Alarm and Signaling Code; Most Recent Edition Cited by Referring Code or Reference Standard.

**1.04 SUBMITTALS**

- A. See Section 013000 - Administrative Requirements, for submittal procedures.
- B. Proposal Documents: Submit the following with cost/time proposal:
  - 1. NFPA 72 "Record of Completion", filled out to the extent known at the time.
  - 2. Manufacturer's detailed data sheet for each control unit, initiating device, and notification appliance.
  - 3. Certification by Contractor that the system design will comply with Contract Documents.
  - 4. Proposed maintenance contract.
- C. Drawings must be prepared using AutoCAD Release \_\_\_\_.
- D. Evidence of designer qualifications.
- E. Design Documents: Submit all information required for plan review and permitting by authorities having jurisdiction, including but not limited to floor plans, riser diagrams, and description of operation:
  - 1. Copy (if any) of list of data required by authority having jurisdiction.
  - 2. NFPA 72 "Record of Completion", filled out to the extent known at the time.
  - 3. Clear and concise description of operation, with input/output matrix similar to that shown in NFPA 72 Appendix A-7-5-2.2(9), and complete listing of software required.
  - 4. System zone boundaries and interfaces to fire safety systems.
  - 5. Location of all components, circuits, and raceways; mark components with identifiers used in control unit programming.
  - 6. Circuit layouts; number, size, and type of raceways and conductors; conduit fill calculations; spare capacity calculations; notification appliance circuit voltage drop calculations.
  - 7. List of all devices on each signaling line circuit, with spare capacity indicated.
  - 8. Manufacturer's detailed data sheet for each component, including wiring diagrams, installation instructions, and circuit length limitations.
  - 9. Description of power supplies; if secondary power is by battery include calculations demonstrating adequate battery power.
  - 10. Certification by either the manufacturer of the control unit or by the manufacturer of each other component that the components are compatible with the control unit.

11. Certification by the manufacturer of the control unit that the system design complies with Contract Documents.
  12. Certification by Contractor that the system design complies with Contract Documents.
- F. Evidence of installer qualifications.
- G. Evidence of instructor qualifications; training lesson plan outline.
- H. Evidence of maintenance contractor qualifications, if different from installer.
- I. Inspection and Test Reports:
1. Submit inspection and test plan prior to closeout demonstration.
  2. Submit documentation of satisfactory inspections and tests.
  3. Submit NFPA 72 "Inspection and Test Form," filled out.
- J. Operating and Maintenance Data: See Section 017800 for additional requirements; revise and resubmit until acceptable; have one set available during closeout demonstration:
1. Complete set of specified design documents, as approved by authority having jurisdiction.
  2. Additional printed set of project record documents and closeout documents, bound or filed in same manuals.
  3. Contact information for firm that will be providing contract maintenance and trouble call-back service.
  4. List of recommended spare parts, tools, and instruments for testing.
  5. Replacement parts list with current prices, and source of supply.
  6. Detailed troubleshooting guide and large scale input/output matrix.
  7. Preventive maintenance, inspection, and testing schedule complying with NFPA 72; provide printed copy and computer format acceptable to Owner.
  8. Detailed but easy to read explanation of procedures to be taken by non-technical administrative personnel in the event of system trouble, when routine testing is being conducted, for fire drills, and when entering into contracts for remodeling.
- K. Project Record Documents: See Section 017800 for additional requirements; have one set available during closeout demonstration:
1. Complete set of floor plans showing actual installed locations of components, conduit, and zones.
  2. "As installed" wiring and schematic diagrams, with final terminal identifications.
  3. "As programmed" operating sequences, including control events by device, updated input/output chart, and voice messages by event.
- L. Closeout Documents:
1. Certification by manufacturer that the system has been installed in compliance with manufacturer's installation requirements, is complete, and is in satisfactory operating condition.
  2. NFPA 72 "Record of Completion", filled out completely and signed by installer and authorized representative of authority having jurisdiction.

#### **1.05 QUALITY ASSURANCE**

- A. Designer Qualifications: NICET Level III or IV (3 or 4) certified fire alarm technician or registered fire protection engineer, employed by fire alarm control panel manufacturer, Contractor, or installer, with experience designing fire alarm systems in the jurisdictional area of the authorities having jurisdiction.
- B. Installer Qualifications: Firm with minimum 3 years documented experience installing fire alarm systems of the specified type and providing contract maintenance service as a regular part of their business.
1. Authorized representative of control unit manufacturer; submit manufacturer's certification that installer is authorized; include name and title of manufacturer's representative making certification.
  2. Installer Personnel: At least 2 years of experience installing fire alarm systems.
  3. Supervisor: NICET level III or IV (3 or 4) certified fire alarm technician; furnish name and address.

- C. Maintenance Contractor Qualifications: Same entity as installer or different entity with specified qualifications.
- D. Instructor Qualifications: Experienced in technical instruction, understanding fire alarm theory, and able to provide the required training; trained by fire alarm control unit manufacturer.

## **PART 2 PRODUCTS**

### **2.01 FIRE ALARM SYSTEM**

- A. Fire Alarm System: Provide a new automatic fire detection and alarm system:
  - 1. Provide all components necessary, regardless of whether shown in Contract Documents or not.
  - 2. Protected Premises: Entire building shown on drawings.
  - 3. Comply with the following; where requirements conflict, order of precedence of requirements is as listed:
    - a. ADA Standards.
    - b. The requirements of the local authority having jurisdiction , which is \_\_\_\_\_.
    - c. Applicable local codes.
    - d. Contract Documents (drawings and specifications).
    - e. NFPA 72; where the word "should" is used consider that provision mandatory; where conflicts between requirements require deviation from NFPA 72, identify deviations clearly on design documents.
  - 4. Evacuation Alarm: Multiple smoke zones; allow for evacuation notification of any individual zone or combination of zones, in addition to general evacuation of entire premises.
  - 5. Voice Notification: Provide emergency voice/alarm communications with multichannel capability; digital.
  - 6. General Evacuation Zones: Each smoke zone is considered a general evacuation zone unless otherwise indicated, with alarm notification in all zones on the same floor, on the floor above, and the floor below.
  - 7. Program notification zones and voice messages as directed by Owner.
  - 8. Fire Command Center: Location indicated on drawings.
  - 9. Fire Alarm Control Unit: New, located at fire command center.
- B. Supervising Stations and Fire Department Connections:
  - 1. Public Fire Department Notification: By on-premises supervising station.
  - 2. On-Premises Supervising Station: Existing proprietary station operated by Owner, located at \_\_\_\_\_.
  - 3. Means of Transmission to On-Premises Supervising Station: Directly connected noncoded system.
- C. Circuits:
  - 1. Initiating Device Circuits (IDC): Class B, Style A.
  - 2. Signaling Line Circuits (SLC) Within Single Building: Class B, Style 0.5.
  - 3. Notification Appliance Circuits (NAC): Class B, Style W.
- D. Power Sources:
  - 1. Primary: Dedicated branch circuits of the facility power distribution system.
  - 2. Secondary: Storage batteries.
  - 3. Capacity: Sufficient to operate entire system for period specified by NFPA 72.
  - 4. Each Computer System: Provide uninterruptible power supply (UPS).

### **2.02 FIRE SAFETY SYSTEMS INTERFACES**

- A. Supervision: Provide supervisory signals in accordance with NFPA 72 for the following:
- B. Alarm: Provide alarm initiation in accordance with NFPA 72 for the following:
- C. Elevators:
  - 1. Elevator lobby, hoistway, and machine room smoke detectors: Elevator recall for fire fighters' service.

2. Elevator Machine Room Heat Detector: Shut down elevator power prior to hoistway sprinkler activation.

D. HVAC:

1. Duct Smoke Detectors: Close dampers indicated; shut down air handlers indicated.

## 2.03 COMPONENTS

A. General:

1. Provide flush mounted units where installed in finish areas; in unfinished areas, surface mounted unit are acceptable.
2. Provide legible, permanent labels for each control device, using identification used in operation and maintenance data.

B. Fire Alarm Control Units: Analog, addressable type; listed, classified, and labeled as suitable for the purpose intended.

C. Master Control Unit: \_\_\_\_\_.

D. Initiating Devices:

1. Addressable Systems:
  - a. Addressable Devices: Individually identifiable by addressable fire alarm control unit.
  - b. Provide suitable addressable interface modules as indicated or as required for connection to conventional (non-addressable) devices and other components that provide a dry closure output.

E. Notification Appliances:

F. Circuit Conductors: Copper or optical fiber; provide 200 feet (60 m) extra; color code and label.

G. Surge Protection: In accordance with IEEE C62.41.2 category B combination waveform and NFPA 70; except for optical fiber conductors.

H. Locks and Keys: Deliver keys to Owner.

I. Instruction Charts: Printed instruction chart for operators, showing steps to be taken when a signal is received (normal, alarm, supervisory, and trouble); easily readable from normal operator's station.

1. Frame: Stainless steel or aluminum with polycarbonate or glass cover.
2. Provide one for each control unit where operations are to be performed.
3. Obtain approval of Owner prior to mounting; mount in location acceptable to Owner.
4. Provide extra copy with operation and maintenance data submittal.

## PART 3 EXECUTION

### 3.01 INSTALLATION

- A. Install in accordance with applicable codes, NFPA 72, NFPA 70, and Contract Documents.
- B. Conceal all wiring, conduit, boxes, and supports where installed in finished areas.
- C. Obtain Owner's approval of locations of devices, before installation.
- D. Install instruction cards and labels.

### 3.02 INSPECTION AND TESTING FOR COMPLETION

- A. Notify Owner 7 days prior to beginning completion inspections and tests.
- B. Notify authorities having jurisdiction and comply with their requirements for scheduling inspections and tests and for observation by their personnel.
- C. Provide the services of the installer's supervisor or person with equivalent qualifications to supervise inspection and testing, correction, and adjustments.
- D. Prepare for testing by ensuring that all work is complete and correct; perform preliminary tests as required.
- E. Provide all tools, software, and supplies required to accomplish inspection and testing.
- F. Perform inspection and testing in accordance with NFPA 72 and requirements of local authorities; document each inspection and test.

- G. Correct defective work, adjust for proper operation, and retest until entire system complies with Contract Documents.

### **3.03 OWNER PERSONNEL INSTRUCTION**

- A. Provide the following instruction to designated Owner personnel:
  - 1. Hands-On Instruction: On-site, using operational system.
  - 2. Classroom Instruction: Owner furnished classroom, on-site or at other local facility.
- B. Administrative: One-hour session(s) covering issues necessary for non-technical administrative staff; classroom:
  - 1. Initial Training: 1 session pre-closeout.
- C. Basic Operation: One-hour sessions for attendant personnel, security officers, and engineering staff; combination of classroom and hands-on:
  - 1. Initial Training: 1 session pre-closeout.
- D. Furnish the services of instructors and teaching aids; have copies of operation and maintenance data available during instruction.

### **3.04 CLOSEOUT**

- A. Closeout Demonstration: Demonstrate proper operation of all functions to Owner.
  - 1. Be prepared to conduct any of the required tests.
  - 2. Have at least one copy of operation and maintenance data, preliminary copy of project record drawings, input/output matrix, and operator instruction chart(s) available during demonstration.
  - 3. Have authorized technical representative of control unit manufacturer present during demonstration.
  - 4. Demonstration may be combined with inspection and testing required by authority having jurisdiction; notify authority having jurisdiction in time to schedule demonstration.
  - 5. Repeat demonstration until successful.

### **3.05 MAINTENANCE**

- A. See Section 017000 - Execution and Closeout Requirements, for additional requirements relating to maintenance service.
- B. Provide to Owner, a proposal as an alternate to the base bid, for a maintenance contract for entire warranty period, to include the work described below; include the total cost of contract, proposal to be valid at least until 30 days after date of Substantial Completion.
- C. Perform routine inspection, testing, and preventive maintenance required by NFPA 72, including:
  - 1. Maintenance of fire safety interface and supervisory devices connected to fire alarm system.
  - 2. Repairs required, unless due to improper use, accidents, or negligence beyond the control of the maintenance contractor.
  - 3. Record keeping required by NFPA 72 and authorities having jurisdiction.
- D. Provide trouble call-back service upon notification by Owner:
  - 1. Provide on-site response within 2 hours of notification.
  - 2. Include allowance for call-back service during normal working hours at no extra cost to Owner.
  - 3. Owner will pay for call-back service outside of normal working hours on an hourly basis, based on actual time spent at site and not including travel time; include hourly rate and definition of normal working hours in maintenance contract.
- E. Provide a complete description of preventive maintenance, systematic examination, adjustment, cleaning, inspection, and testing, with a detailed schedule.
- F. Maintain a log at each fire alarm control unit, listing the date and time of each inspection and call-back visit, the condition of the system, nature of the trouble, correction performed, and parts replaced. Submit duplicate of each log entry to Owner's representative upon completion of site visit.

G. Comply with Owner's requirements for access to facility and security.

**END OF SECTION**

**SECTION 311000  
SITE CLEARING**

**PART 2 PRODUCTS -- NOT USED**

**PART 3 EXECUTION**

**2.01 SITE CLEARING**

- A. Comply with other requirements specified in Section 017000.
- B. Minimize production of dust due to clearing operations; do not use water if that will result in ice, flooding, sedimentation of public waterways or storm sewers, or other pollution.

**2.02 VEGETATION**

- A. Do not remove or damage vegetation beyond the limits indicated on drawings.
- B. Install substantial, highly visible fences at least 3 feet high (at least 1 m high) to prevent inadvertent damage to vegetation to remain:
  - 1. At vegetation removal limits.
- C. In areas where vegetation must be removed but no construction will occur other than pervious paving, remove vegetation with minimum disturbance of the subsoil.
- D. Vegetation Removed: Do not burn, bury, landfill, or leave on site, except as indicated.
  - 1. Chip, grind, crush, or shred vegetation for mulching, composting, or other purposes; preference should be given to on-site uses.
  - 2. Trees: Sell if marketable; if not, treat as specified for other vegetation removed; remove stumps and roots to depth of 18 inches (450 mm).
  - 3. Sod: Re-use on site if possible; otherwise sell if marketable, and if not, treat as specified for other vegetation removed.
- E. Restoration: If vegetation outside removal limits or within specified protective fences is damaged or destroyed due to subsequent construction operations, replace at no cost to Owner.

**2.03 DEBRIS**

- A. Remove debris, junk, and trash from site.
- B. Leave site in clean condition, ready for subsequent work.
- C. Clean up spillage and wind-blown debris from public and private lands.

**END OF SECTION**

**SECTION 312200  
GRADING**

**PART 1 GENERAL**

**1.01 SECTION INCLUDES**

- A. Removal of topsoil.
- B. Rough grading the site for site structures.
- C. Finish grading.

**1.02 RELATED REQUIREMENTS**

- A. Section 312316 - Excavation.
- B. Section 312323 - Fill: Filling and compaction.
- C. Section 329219 - Seeding: Finish ground cover.

**PART 2 PRODUCTS**

**2.01 MATERIALS**

- A. Topsoil: Topsoil excavated on-site.
  - 1. Graded.
  - 2. Free of roots, rocks larger than 1/2 inch (12 mm), subsoil, debris, large weeds and foreign matter.
- B. Other Fill Materials: See Section 312323.

**PART 3 EXECUTION**

**3.01 EXAMINATION**

- A. Verify that survey bench mark and intended elevations for the Work are as indicated.
- B. Verify the absence of standing or ponding water.

**3.02 PREPARATION**

- A. Identify required lines, levels, contours, and datum.
- B. Stake and flag locations of known utilities.
- C. Locate, identify, and protect from damage above- and below-grade utilities to remain.
- D. Provide temporary means and methods to remove all standing or ponding water from areas prior to grading.
- E. Protect site features to remain, including but not limited to existing structures, sidewalks, paving, and curbs, from damage by grading equipment and vehicular traffic.
- F. Protect trees to remain by providing substantial fencing around entire tree at the outer tips of its branches; no grading is to be performed inside this line.
- G. Protect plants and lawns to remain as a portion of final landscaping.

**3.03 ROUGH GRADING**

- A. Remove topsoil from areas to be further excavated, re-landscaped, or re-graded, without mixing with foreign materials.
- B. Do not remove topsoil when wet.
- C. Remove subsoil from areas to be further excavated, re-landscaped, or re-graded.
- D. Do not remove wet subsoil, unless it is subsequently processed to obtain optimum moisture content.
- E. When excavating through roots, perform work by hand and cut roots with sharp axe.
- F. Stability: Replace damaged or displaced subsoil to same requirements as for specified fill.
- G. Remove and replace soils deemed unsuitable by classification and which are excessively moist due to lack surface water control.



### **3.04 SOIL REMOVAL AND STOCKPILING**

- A. Stockpile topsoil to be re-used on site; remove remainder from site.
- B. Stockpile subsoil to be re-used on site; remove remainder from site.
- C. Stockpiles: Use areas designated on site; pile depth not to exceed 8 feet (2.5 m); protect from erosion.

### **3.05 FINISH GRADING**

- A. Before Finish Grading:
  - 1. Verify building and trench backfilling have been inspected.
  - 2. Verify subgrade has been contoured and compacted.
- B. Remove debris, roots, branches, stones, in excess of 1/2 inch (13 mm) in size. Remove soil contaminated with petroleum products.
- C. In areas where vehicles or equipment have compacted soil, scarify surface to depth of 3 inches (75 mm).
- D. Place topsoil in areas where seeding are indicated.
- E. Place topsoil where required to level finish grade.
- F. Place topsoil to the following compacted thicknesses:
  - 1. Areas to be Seeded with Grass: 6 inches (150 mm).
  - 2. Shrub Beds: 18 inches (450 mm).
- G. Place topsoil during dry weather.
- H. Remove roots, weeds, rocks, and foreign material while spreading.
- I. Near plants spread topsoil manually to prevent damage.
- J. Fine grade topsoil to eliminate uneven areas and low spots. Maintain profiles and contour of subgrade.
- K. Lightly compact placed topsoil.
- L. Maintain stability of topsoil during inclement weather. Replace topsoil in areas where surface water has eroded thickness below specifications.

### **3.06 TOLERANCES**

- A. Top Surface of Subgrade: Plus or minus 0.10 foot (1-3/16 inches) (30 mm) from required elevation.
- B. Top Surface of Finish Grade: Plus or minus 0.04 foot (1/2 inch) (13 mm).

### **3.07 REPAIR AND RESTORATION**

- A. Existing Facilities, Utilities, and Site Features to Remain: If damaged due to this work, repair or replace to original condition.
- B. Other Existing Vegetation to Remain: If damaged due to this work, replace with vegetation of equivalent species and size.

### **3.08 FIELD QUALITY CONTROL**

- A. See Section 312323 for compaction density testing.

**END OF SECTION**

**SECTION 312316  
EXCAVATION**

**PART 1 GENERAL**

**1.01 SECTION INCLUDES**

- A. Excavating for footings, slabs-on-grade, paving, and site structures.
- B. Trenching for utilities outside the building to utility main connections.

**PART 2 PRODUCTS**

**PART 3 EXECUTION**

**3.01 EXCAVATING**

- A. Excavate to accommodate new structures and construction operations.
- B. Notify Architect of unexpected subsurface conditions and discontinue affected Work in area until notified to resume work.
- C. Provide temporary means and methods, as required, to remove all water from excavations until directed by Architect. Remove and replace soils deemed suitable by classification and which are excessively moist due to lack of dewatering or surface water control.

**3.02 FILLING AND BACKFILLING**

- A. Do not fill or backfill until all debris, water, unsatisfactory soil materials, obstructions, and deleterious materials have been removed from excavation.

**3.03 FIELD QUALITY CONTROL**

- A. See Section 014000 - Quality Requirements, for general requirements for field inspection and testing.
- B. Provide for visual inspection of load-bearing excavated surfaces by Architect before placement of foundations.

**3.04 CLEANING**

- A. Stockpile excavated material to be re-used in area designated on site in accordance with Section 312200.
- B. Remove excavated material that is unsuitable for re-use from site.
- C. Remove excess excavated material from site.

**3.05 PROTECTION**

- A. Divert surface flow from rains or water discharges from the excavation.
- B. Prevent displacement of banks and keep loose soil from falling into excavation; maintain soil stability.
- C. Protect open excavations from rainfall, runoff, freezing groundwater, or excessive drying so as to maintain foundation subgrade in satisfactory, undisturbed condition.
- D. Protect bottom of excavations and soil adjacent to and beneath foundation from freezing.
- E. Keep excavations free of standing water and completely free of water during concrete placement.

**END OF SECTION**

**SECTION 312323  
FILL**

**PART 1 GENERAL**

**1.01 SECTION INCLUDES**

- A. Filling, backfilling, and compacting for footings, paving, and site structures.
- B. Backfilling and compacting for utilities outside the building to utility main connections.
- C. Filling holes, pits, and excavations generated as a result of removal (demolition) operations.

**1.02 RELATED REQUIREMENTS**

- A. Section 329119 - Landscape Grading.

**REFERENCE STANDARDS**

- B. ASTM D2487 - Standard Practice for Classification of Soils for Engineering Purposes (Unified Soil Classification System); 2017, with Editorial Revision (2020).

**1.03 SUBMITTALS**

- A. See Section 013000 - Administrative Requirements, for submittal procedures.
- B. Materials Sources: Submit name of imported materials source.

**1.04 DELIVERY, STORAGE, AND HANDLING**

- A. When necessary, store materials on site in advance of need.
- B. When fill materials need to be stored on site, locate stockpiles where indicated.
  - 1. Separate differing materials with dividers or stockpile separately to prevent intermixing.
  - 2. Prevent contamination.
  - 3. Protect stockpiles from erosion and deterioration of materials.

**PART 2 PRODUCTS**

**2.01 FILL MATERIALS**

- A. General Fill: Subsoil excavated on-site.
  - 1. Graded.
  - 2. Free of lumps larger than 3 inches (75 mm), rocks larger than 2 inches (50 mm), and debris.
  - 3. Complying with ASTM D2487 Group Symbol CL.

**2.02 SOURCE QUALITY CONTROL**

- A. See Section 014000 - Quality Requirements, for general requirements for testing and analysis of soil material.
- B. If tests indicate materials do not meet specified requirements, change material and retest.

**PART 3 EXECUTION**

**3.01 EXAMINATION**

- A. Identify required lines, levels, contours, and datum locations.
- B. Verify areas to be filled are not compromised with surface or ground water.

**3.02 PREPARATION**

- A. Scarify and proof roll subgrade surface to a depth of 6 inches (150 mm) to identify soft spots.
- B. Cut out soft areas of subgrade not capable of compaction in place. Backfill with general fill.
- C. Compact subgrade to density equal to or greater than requirements for subsequent fill material.
- D. Until ready to fill, maintain excavations and prevent loose soil from falling into excavation.

**3.03 FILLING**

- A. Fill to contours and elevations indicated using unfrozen materials.
- B. Employ a placement method that does not disturb or damage other work.

- C. Systematically fill to allow maximum time for natural settlement. Do not fill over porous, wet, frozen or spongy subgrade surfaces.
- D. Maintain optimum moisture content of fill materials to attain required compaction density.
- E. Slope grade away from building minimum 2 inches in 10 feet (50 mm in 3 m), unless noted otherwise. Make gradual grade changes. Blend slope into level areas.
- F. Correct areas that are over-excavated.
  - 1. Other areas: Use general fill, flush to required elevation, compacted to minimum 97 percent of maximum dry density.
- G. Compaction Density Unless Otherwise Specified or Indicated:
- H. Reshape and re-compact fills subjected to vehicular traffic.
- I. Maintain temporary means and methods, as required, to remove all water while fill is being placed as required, or until directed by the Architect. Remove and replace soils deemed unsuitable by classification and which are excessively moist due to lack of dewatering or surface water control.

### **3.04 FILL AT SPECIFIC LOCATIONS**

- A. Use general fill unless otherwise specified or indicated.
- B. At Footings:
  - 1. Use general fill.
  - 2. Fill up to subgrade elevation.
  - 3. Compact each lift to 90 percent of maximum dry density.
  - 4. Do not backfill against unsupported foundation walls.
  - 5. Backfill simultaneously on each side of unsupported foundation walls until supports are in place.
- C. At Lawn Areas:
  - 1. Use general fill.
  - 2. Fill up to 6 inches (150 mm) below finish grade elevations.
  - 3. Fill up to subgrade elevations.
  - 4. Compact to 95 percent of maximum dry density.
  - 5. See Section 329119 for topsoil placement.

### **3.05 TOLERANCES**

- A. Top Surface of General Filling: Plus or minus 1 inch (25 mm) from required elevations.

### **3.06 CLEANING**

- A. See Section 017419 - Construction Waste Management and Disposal, for additional requirements.
- B. Remove unused stockpiled materials, leave area in a clean and neat condition. Grade stockpile area to prevent standing surface water.
- C. Leave borrow areas in a clean and neat condition. Grade to prevent standing surface water.

**END OF SECTION**

**SECTION 321216  
ASPHALT PAVING**

**PART 1 GENERAL**

**1.01 RELATED REQUIREMENTS**

- A. Section 312200 - Grading: Preparation of site for paving and base.
- B. Section 321123 - Aggregate Base Courses: Aggregate base course.

**1.02 REFERENCE STANDARDS**

- A. AI MS-2 - Asphalt Mix Design Methods; 2015.
- B. ASTM C136/C136M - Standard Test Method for Sieve Analysis of Fine and Coarse Aggregates; 2019.
- C. ASTM D946 - Standard Specification for Penetration-Graded Asphalt Cement for Use in Pavement Construction; 2009a.
- D. ASTM D4318 - Standard Test Methods for Liquid Limit, Plastic Limit, and Plasticity Index of Soils; 2017, with Editorial Revision (2018).

**1.03 QUALITY ASSURANCE**

- A. Perform Work in accordance with State of Indiana Highways standard.
- B. Mixing Plant: Complying with State of Indiana Highways standard.
- C. Obtain materials from same source throughout.

**1.04 FIELD CONDITIONS**

- A. Do not place asphalt when ambient air or base surface temperature is less than 40 degrees F (4 degrees C), or surface is wet or frozen.

**PART 2 PRODUCTS**

**2.01 MATERIALS**

- A. Asphalt Cement: ASTM D946.
- B. Aggregate for Base Course: In accordance with State of Indiana Highways standards.
- C. Aggregate for Binder Course: In accordance with State of Indiana Highways standards.
- D. Fine Aggregate: In accordance with State of Indiana Highways standards.
- E. Tack Coat: Homogeneous, medium curing, liquid asphalt.

**2.02 ASPHALT PAVING MIXES AND MIX DESIGN**

- A. Submit proposed mix design of each class of mix for review prior to beginning of work.

**2.03 SOURCE QUALITY CONTROL**

- A. Test mix design and samples in accordance with AI MS-2.

**PART 3 EXECUTION**

**3.01 EXAMINATION**

- A. Verify that compacted subgrade is dry and ready to support paving and imposed loads.
- B. Verify gradients and elevations of base are correct.

**3.02 PLACING ASPHALT PAVEMENT - SINGLE COURSE**

- A. Install Work in accordance with State of Indiana Highways standards.
- B. Place asphalt within 24 hours of applying primer or tack coat.
- C. Compact pavement by rolling to specified density. Do not displace or extrude pavement from position. Hand compact in areas inaccessible to rolling equipment.
- D. Perform rolling with consecutive passes to achieve even and smooth finish without roller marks.

**3.03 PLACING ASPHALT PAVEMENT - DOUBLE COURSE**

- A. Place asphalt binder course within 24 hours of applying primer or tack coat.
- B. Place asphalt wearing course within two hours of placing and compacting binder course.
- C. Compact pavement by rolling to specified density. Do not displace or extrude pavement from position. Hand compact in areas inaccessible to rolling equipment.
- D. Perform rolling with consecutive passes to achieve even and smooth finish, without roller marks.

**3.04 FIELD QUALITY CONTROL**

- A. See Section 014000 - Quality Requirements, for general requirements for quality control.
- B. Provide field inspection and testing. Take samples and perform tests in accordance with AI MS-2.

**END OF SECTION**

**SECTION 321313  
CONCRETE PAVING**

**PART 1 GENERAL**

**1.01 SECTION INCLUDES**

Concrete sidewalks, stair steps, integral curbs, and gutters.

**1.02 RELATED REQUIREMENTS**

- A. Section 031000 - Concrete Forming and Accessories.  
Section 033000 - Cast-in-Place Concrete.  
Section 312200 - Grading: Preparation of site for paving and base and preparation of subsoil at pavement perimeter for planting.
- Section 312323 - Fill: Compacted subbase for paving.
- Section 321123 - Aggregate Base Courses

**1.03 REFERENCE STANDARDS**

- A. ACI PRC-211.1 - Selecting Proportions for Normal-Density and High Density-Concrete - Guide; 2022.
- B. ACI PRC-305 - Guide to Hot Weather Concreting; 2020.
- C. ACI PRC-306 - Guide to Cold Weather Concreting; 2016.
- D. ACI SPEC-301 - Specifications for Concrete Construction; 2020.
- E. ASTM A615/A615M - Standard Specification for Deformed and Plain Carbon-Steel Bars for Concrete Reinforcement; 2022.
- F. ASTM A1064/A1064M - Standard Specification for Carbon-Steel Wire and Welded Wire Reinforcement, Plain and Deformed, for Concrete; 2022.
- G. ASTM C39/C39M - Standard Test Method for Compressive Strength of Cylindrical Concrete Specimens; 2023.
- H. ASTM C94/C94M - Standard Specification for Ready-Mixed Concrete; 2023.
- I. ASTM C173/C173M - Standard Test Method for Air Content of Freshly Mixed Concrete by the Volumetric Method; 2023.
- J. ASTM D1751 - Standard Specification for Preformed Expansion Joint Filler for Concrete Paving and Structural Construction (Nonextruding and Resilient Asphalt Types); 2023.
- K. ASTM D1752 - Standard Specification for Preformed Sponge Rubber, Cork, and Recycled PVC Expansion Joint Fillers for Concrete Paving and Structural Construction; 2018 (Reapproved 2023).

**1.04 SUBMITTALS**

- A. See Section 013000 - Administrative Requirements, for submittal procedures.
- B. Product Data: Provide data on joint filler, admixtures, and curing compound.
- C. Design Data: Indicate pavement thickness, designed concrete strength, reinforcement, and typical details.

**PART 2 PRODUCTS**

**2.01 PAVING ASSEMBLIES**

- A. Comply with applicable requirements of ACI SPEC-301.
- B. Concrete Sidewalks and Median Barrier: 3,000 psi (20.7 MPa) 28 day concrete, 4 inches (100 mm) thick, buff color Portland cement, exposed aggregate finish.

**2.02 FORM MATERIALS**

- A. Form Materials: As specified in Section 031000, comply with ACI SPEC-301.

- B. Joint Filler: Preformed; non-extruding bituminous type (ASTM D1751) or sponge rubber or cork (ASTM D1752).
  - 1. Thickness: 1/2 inch (12 mm).

### **2.03 REINFORCEMENT**

- A. Steel Welded Wire Reinforcement: Plain type, ASTM A1064/A1064M; in flat sheets; unfinished.
- B. Dowels: ASTM A615/A615M, Grade 40 - 40,000 psi (280 MPa) yield strength; deformed billet steel bars; unfinished finish.

### **2.04 CONCRETE MATERIALS**

- A. Obtain cementitious materials from same source throughout.
- B. Concrete Materials: As specified in Section 033000.

### **2.05 ACCESSORIES**

### **2.06 CONCRETE MIX DESIGN**

- A. Proportioning Normal Weight Concrete: Comply with ACI PRC-211.1 recommendations.
- B. Concrete Properties:
  - 1. Compressive strength, when tested in accordance with ASTM C39/C39M at 28 days; 3000 psi (20 MPa).
  - 2. Water-Cement Ratio: Maximum 40 percent by weight.
  - 3. Total Air Content: 4 percent, determined in accordance with ASTM C173/C173M.
  - 4. Maximum Slump: 3 inches (75 mm).
  - 5. Maximum Aggregate Size: 3/4 inch (19 mm).

### **2.07 MIXING**

- A. Transit Mixers: Comply with ASTM C94/C94M.

## **PART 3 EXECUTION**

### **3.01 EXAMINATION**

- A. Verify compacted subgrade is acceptable and ready to support paving and imposed loads.
- B. Verify gradients and elevations of base are correct.

### **3.02 SUBBASE**

- A. See Section 321123 for construction of base course for work of this Section.

### **3.03 PREPARATION**

- A. Moisten base to minimize absorption of water from fresh concrete.
- B. Notify Architect minimum 24 hours prior to commencement of concreting operations.

### **3.04 FORMING**

- A. Place and secure forms to correct location, dimension, profile, and gradient.
- B. Assemble formwork to permit easy stripping and dismantling without damaging concrete.
- C. Place joint filler vertical in position, in straight lines. Secure to formwork during concrete placement.

### **3.05 REINFORCEMENT**

- A. Place reinforcement at midheight of slabs-on-grade.
- B. Interrupt reinforcement at contraction joints.
- C. Place dowels to achieve pavement and curb alignment as detailed.

### **3.06 COLD AND HOT WEATHER CONCRETING**

- A. Follow recommendations of ACI PRC-305 when concreting during hot weather.
- B. Follow recommendations of ACI PRC-306 when concreting during cold weather.



- C. Do not place concrete when base surface temperature is less than 40 degrees F (4 degrees C), or surface is wet or frozen.

### **3.07 PLACING CONCRETE**

- A. Do not place concrete when base surface is wet.
- B. Ensure reinforcement, inserts, embedded parts, formed joints and \_\_\_\_\_ are not disturbed during concrete placement.
- C. Place concrete continuously over the full width of the panel and between predetermined construction joints. Do not break or interrupt successive pours such that cold joints occur.

### **3.08 JOINTS**

- A. Align curb, gutter, and sidewalk joints.
- B. Place 3/8 inch (10 mm) wide expansion joints at 20 foot (6 m) intervals and to separate paving from vertical surfaces and other components and in pattern indicated.
  - 1. Form joints with joint filler extending from bottom of pavement to within 1/2 inch (13 mm) of finished surface.
  - 2. Secure to resist movement by wet concrete.
- C. Provide scored joints.
  - 1. At 3 feet (1 m) intervals.
  - 2. Between sidewalks and curbs.
  - 3. Between curbs and pavement.
- D. Saw cut contraction joints 3/16 inch (5 mm) wide at an optimum time after finishing. Cut 1/3 into depth of slab.

### **3.09 FINISHING**

- A. Sidewalk Paving: Light broom, texture perpendicular to direction of travel with troweled and radiused edge 1/4 inch radius (6 mm radius).
- B. Place curing compound on exposed concrete surfaces immediately after finishing. Apply in accordance with manufacturer's instructions.

### **3.10 TOLERANCES**

- A. Maximum Variation of Surface Flatness: 1/4 inch (6 mm) in 10 ft (3 m).
- B. Maximum Variation From True Position: 1/4 inch (6 mm).

### **3.11 PROTECTION**

- A. Immediately after placement, protect pavement from premature drying, excessive hot or cold temperatures, and mechanical injury.
- B. Do not permit pedestrian traffic over pavement until 75 percent design strength of concrete has been achieved.

**END OF SECTION**

**SECTION 321623  
SIDEWALKS**

**PART 2 PRODUCTS**

**END OF SECTION**

**SECTION 329219  
SEEDING**

**PART 1 GENERAL**

**1.01 SECTION INCLUDES**

- A. Preparation of subsoil.
- B. Placing topsoil.
- C. Seeding, mulching and fertilizer.
- D. Maintenance.

**1.02 RELATED REQUIREMENTS**

- A. Section 312200 - Grading: Preparation of subsoil topsoil in preparation for the work of this section.

**1.03 DEFINITIONS**

- A. Weeds: Include Dandelion, Jimsonweed, Quackgrass, Horsetail, Morning Glory, Rush Grass, Mustard, Lambsquarter, Chickweed, Cress, Crabgrass, Canadian Thistle, Nutgrass, Poison Oak, Blackberry, Tansy Ragwort, Bermuda Grass, Johnson Grass, Poison Ivy, Nut Sedge, Nimble Will, Bindweed, Bent Grass, Wild Garlic, Perennial Sorrel, and Brome Grass.

**1.04 SUBMITTALS**

- A. See Section 013000 - Administrative Requirements, for submittal procedures.
- B. Certificate: Certify seed mixture approval by authority having jurisdiction.

**PART 2 PRODUCTS**

**2.01 REGULATORY REQUIREMENTS**

- A. Provide certificate of compliance from authority having jurisdiction indicating approval of seed mixture.

**2.02 SEED MIXTURE**

- A. Seed Mixture:
  - 1. Kentucky Blue Grass: 50 percent.
  - 2. Creeping Red Fescue Grass: 30 percent.
  - 3. Red Top: 10 percent.
  - 4. Norlea Perennial Rye: 10 percent.

**2.03 SOIL MATERIALS**

- A. Topsoil: Excavated from site and free of weeds.

**2.04 ACCESSORIES**

- A. Mulching Material: Oat or wheat straw, free from weeds, foreign matter detrimental to plant life, and dry. Hay or chopped cornstalks are not acceptable.

**PART 3 EXECUTION**

**3.01 PREPARATION**

- A. Prepare subgrade in accordance with Section 312200.
- B. Place topsoil in accordance with Section 312200.

**3.02 SEEDING**

- A. Apply seed at a rate of 5 lbs per 1000 sq ft (\_\_\_\_) evenly in two intersecting directions. Rake in lightly.
- B. Do not seed areas in excess of that which can be mulched on same day.
- C. Do not sow immediately following rain, when ground is too dry, or during windy periods.
- D. Immediately following seeding and compacting, apply mulch to a thickness of 1/8 inches (3 mm). Maintain clear of shrubs and trees.

- E. Apply water with a fine spray immediately after each area has been mulched. Saturate to 4 inches (100 mm) of soil.
- F. Following germination, immediately re-seed areas without germinated seeds that are larger than 4 by 4 inches (100 by 100 mm).

### **3.03 PROTECTION**

- A. Cover seeded slopes where grade is 4 inches per foot or greater with erosion fabric. Roll fabric onto slopes without stretching or pulling.
- B. At sides of ditches, lay fabric laps in direction of water flow. Lap ends and edges minimum 6 inches (150 mm).

### **3.04 MAINTENANCE**

- A. Provide maintenance at no extra cost to Owner; Owner will pay for water.
- B. See Section 017000 - Execution Requirements, for additional requirements relating to maintenance service.
- C. Mow grass at regular intervals to maintain at a maximum height of 2-1/2 inches (65 mm). Do not cut more than 1/3 of grass blade at any one mowing.
- D. Neatly trim edges and hand clip where necessary.
- E. Immediately remove clippings after mowing and trimming.
- F. Water to prevent grass and soil from drying out.
- G. Roll surface to remove minor depressions or irregularities.
- H. Control growth of weeds. Apply herbicides in accordance with manufacturer's instructions. Remedy damage resulting from improper use of herbicides.
- I. Immediately reseed areas that show bare spots.
- J. Protect seeded areas with warning signs during maintenance period.

**END OF SECTION**

**SECTION 330561  
CONCRETE MANHOLES**

**PART 1 GENERAL**

**1.01 SECTION INCLUDES**

- A. Precast concrete manholes.
- B. Frames and covers.

**1.02 REFERENCE STANDARDS**

- A. ASTM A48/A48M - Standard Specification for Gray Iron Castings; 2022.
- B. ASTM C478/C478M - Standard Specification for Circular Precast Reinforced Concrete Manhole Sections; 2020.
- C. ASTM C923/C923M - Standard Specification for Resilient Connectors Between Reinforced Concrete Manhole Structures, Pipes, and Laterals; 2020.

**1.03 SUBMITTALS**

- A. See Section 013000 - Administrative Requirements, for submittal procedures.
- B. Shop Drawings: Indicate manhole locations, elevations, piping sizes and elevations of penetrations.

**PART 2 PRODUCTS**

**2.01 CONCRETE MANHOLES**

- A. Manhole Sections: Reinforced precast concrete in accordance with ASTM C478/C478M, with resilient connectors complying with ASTM C923/C923M.
- B. Concrete: As specified in Section 03 3000.
- C. Concrete Reinforcement: As specified in Section 03 3000.

**PART 3 EXECUTION**

**3.01 EXAMINATION**

- A. Verify items provided by other sections of work are properly sized and located.
- B. Verify that built-in items are in proper location, and ready for roughing into Work.
- C. Verify excavation for manholes is correct.

**3.02 INSTALLATION**

- A. Establish elevations and pipe inverts for inlets and outlets as indicated in drawings.
- B. Precast Concrete Manholes:
  - 1. Place base section plumb and level.
  - 2. Install joint sealant uniformly around section lip.
- C. Frames and Covers:
  - 1. Place frame plumb and level.
  - 2. Place grate in frame securely.

**3.03 FIELD QUALITY CONTROL**

- A. See Section 014000 - Quality Requirements for additional requirements.
- B. Perform field inspection for pipe invert elevations.
- C. If inspections indicate work does not meet specified requirements, adjust work and reinspect at no cost to Owner.

**END OF SECTION**

**SECTION 331416  
SITE WATER UTILITY DISTRIBUTION PIPING**

**PART 1 GENERAL**

**1.01 SECTION INCLUDES**

- A. Water pipe for site conveyance lines.

**1.02 RELATED REQUIREMENTS**

- A. Section 033000 - Cast-in-Place Concrete: Concrete for thrust restraints.
- B. Section 312316.13 - Trenching: Excavating, bedding, and backfilling.

**1.03 PRICE AND PAYMENT PROCEDURES**

- A. See Section 012200 - Unit Prices, for additional unit price requirements.

**1.04 REFERENCE STANDARDS**

- A. ASTM D3035 - Standard Specification for Polyethylene (PE) Plastic Pipe (DR-PR) Based on Controlled Outside Diameter; 2022.
- B. AWWA C901 - Polyethylene (PE) Pressure Pipe and Tubing, 3/4 In. (19 mm) Through 3 In. (76 mm), for Water Service; 2020.

**PART 2 PRODUCTS**

**2.01 WATER PIPE**

- A. Polyethylene Pipe: ASTM D3035, for 45 psig pressure rating (ASTM D3035, for 315 kPa pressure rating):
- B. Polyethylene Pipe: AWWA C901:
- C. Trace Wire: Magnetic detectable conductor, clear plastic covering, imprinted with "Water Service" in large letters.

**2.02 ACCESSORIES**

**PART 3 EXECUTION**

**3.01 EXAMINATION**

- A. Verify that building service connection and municipal utility water main size, location, and invert are as indicated.

**3.02 PREPARATION**

- A. Cut pipe ends square, ream pipe and tube ends to full pipe diameter, remove burrs.
- B. Remove scale and dirt on inside and outside before assembly.
- C. Prepare pipe connections to equipment with flanges or unions.

**3.03 TRENCHING**

- A. See the sections on excavation and fill for additional requirements.
- B. Backfill around sides and to top of pipe with cover fill, tamp in place and compact, then complete backfilling.

**3.04 INSTALLATION - PIPE**

- A. Maintain separation of water main from sewer piping in accordance with Indiana code.
- B. Route pipe in straight line.
- C. Install pipe to allow for expansion and contraction without stressing pipe or joints.
- D. Slope water pipe and position drains at low points.
- E. Install trace wire 6 inches (150 mm) above top of pipe; coordinate with Section 312316.13.

**END OF SECTION**

**SECTION 333113  
SITE SANITARY SEWERAGE GRAVITY PIPING**

**PART 1 GENERAL**

**1.01 SECTION INCLUDES**

- A. Sanitary sewerage drainage piping, fittings, and accessories.
- B. Connection of building sanitary drainage system to municipal sewers.

**1.02 RELATED REQUIREMENTS**

- A. Section 033000 - Cast-in-Place Concrete: Concrete for cleanout base pad construction.
- B. Section 312316.13 - Trenching: Excavating, bedding, and backfilling.
- C. Section 312323 - Fill: Bedding and backfilling.
- D. Section 330561 - Concrete Manholes.

**1.03 DEFINITIONS**

- A. Bedding: Fill placed under, beside and directly over pipe, prior to subsequent backfill operations.

**1.04 REFERENCE STANDARDS**

- A. ASTM D1785 - Standard Specification for Poly(Vinyl Chloride) (PVC) Plastic Pipe, Schedules 40, 80, and 120; 2021a.
- B. ASTM D2321 - Standard Practice for Underground Installation of Thermoplastic Pipe for Sewers and Other Gravity-Flow Applications; 2020.
- C. ASTM D2729 - Standard Specification for Poly(Vinyl Chloride) (PVC) Sewer Pipe and Fittings; 2021.
- D. ASTM D3350 - Standard Specification for Polyethylene Plastics Pipe and Fittings Materials; 2021.

**1.05 SUBMITTALS**

- A. See Section 013000 - Administrative Requirements, for submittal procedures.

**PART 2 PRODUCTS**

**2.01 SEWER PIPE MATERIALS**

- A. Provide products that comply with applicable code(s).
- B. Plastic Pipe: ASTM D1785, Schedule 40, Poly(Vinyl Chloride) (PVC) material; inside nominal diameter of 6 inches (150 mm), bell and spigot style solvent sealed joint end.
- C. Fittings: Same material as pipe molded or formed to suit pipe size and end design, in required tee, bends, elbows, cleanouts, reducers, traps and other configurations required.

**PART 3 EXECUTION**

**3.01 GENERAL**

- A. Perform work in accordance with applicable code(s).

**3.02 TRENCHING**

- A. See Section 312316.13 for additional requirements.
- B. Backfill around sides and to top of pipe with cover fill, tamp in place and compact, then complete backfilling.

**3.03 INSTALLATION - PIPE**

- A. Install pipe, fittings, and accessories in accordance with manufacturer's instructions. Seal watertight.
  - 1. Plastic Pipe: Also comply with ASTM D2321.
- B. Lay pipe to slope gradients noted on layout drawings; with maximum variation from true slope of 1/8 inch (3 mm) in 10 feet (3 m).

- C. Connect to building sanitary sewer outlet and municipal sewer system , through installed sleeves.

**3.04 INSTALLATION - CLEANOUTS**

- A. Form bottom of excavation clean and smooth to correct elevation.
- B. Form and place cast-in-place concrete base pad, with provision for sanitary sewer pipe end sections.
- C. Establish elevations and pipe inverts for inlets and outlets as indicated.
- D. Mount lid and frame level in grout, secured to top cone section to elevation indicated.

**3.05 PROTECTION**

- A. Protect pipe and bedding cover from damage or displacement until backfilling operation is in progress.

**END OF SECTION**



**SECTION 334211  
STORMWATER GRAVITY PIPING**

**PART 1 GENERAL**

**1.01 SECTION INCLUDES**

- A. Stormwater drainage piping.
- B. Stormwater pipe accessories.

**1.02 RELATED REQUIREMENTS**

- A. Section 033000 - Cast-in-Place Concrete: Concrete for cleanout base pad construction.
- B. Section 312316 - Excavation: Excavating of trenches.
- C. Section 312323 - Fill: Bedding and backfilling.
- D. Section 330561 - Concrete Manholes.

**1.03 REFERENCE STANDARDS**

- A. AASHTO M 252 - Standard Specification for Corrugated Polyethylene Drainage Pipe; 2023.
- B. AASHTO M 294 - Standard Specification for Corrugated Polyethylene Pipe, 300- to 1500-mm (12- to 60-in.) Diameter; 2021.
- C. ASTM A48/A48M - Standard Specification for Gray Iron Castings; 2022.
- D. ASTM D1785 - Standard Specification for Poly(Vinyl Chloride) (PVC) Plastic Pipe, Schedules 40, 80, and 120; 2021a.
- E. ASTM D2321 - Standard Practice for Underground Installation of Thermoplastic Pipe for Sewers and Other Gravity-Flow Applications; 2020.
- F. ASTM D2729 - Standard Specification for Poly(Vinyl Chloride) (PVC) Sewer Pipe and Fittings; 2021.
- G. ASTM D3350 - Standard Specification for Polyethylene Plastics Pipe and Fittings Materials; 2021.

**1.04 SUBMITTALS**

- A. See Section 013000 - Administrative Requirements, for submittal procedures.
- B. Product Data: Provide data indicating pipe, pipe accessories.
- C. Project Record Documents:
  - 1. Record location of pipe runs, connections, and invert elevations.
  - 2. Identify and describe unexpected variations to subsoil conditions or discovery of uncharted utilities.

**PART 2 PRODUCTS**

**2.01 STORMWATER PIPE MATERIALS**

- A. Provide products that comply with applicable code(s).
- B. Plastic Pipe: ASTM D1785, Schedule 40, Poly Vinyl Chloride (PVC) material; bell and spigot style solvent sealed joint end.
- C. Plastic Pipe: ASTM D3350, High Density Polyethylene (HDPE) corrugated wall pipe with integrally formed smooth liner; meeting the requirements of AASHTO M 252, Type S, for diameters between 3 inches (75 mm) and 10 inches (250 mm) and AASHTO M 294, Type S, for diameters between 12 inches (300 mm) and 60 inches (1500 mm), soil-tight, bell and spigot joints with rubber gaskets, with pipe and fittings manufactured from virgin PE compounds with cell classification 3254420C.

**2.02 PIPE ACCESSORIES**

- A. Fittings: Same material as pipe molded or formed to suit pipe size and end design, in required tee, bends, elbows, cleanouts, reducers, traps and other configurations required.

- B. Downspout Boots: Smooth interior without boxed corners or choke points; include integral lug slots and on-body cleanout and cover with neoprene gaskets.
  - 1. Configuration: Angular.
  - 2. Material: Cast iron; ASTM A48/A48M; casting thickness 3/8 inch (9.5 mm), minimum.
  - 3. Finish: Manufacturer's standard factory applied primer finish.
  - 4. Accessories: Manufacturer's standard stainless steel fasteners, stainless steel building wall anchors, and rubber coupling.

### **PART 3 EXECUTION**

#### **3.01 TRENCHING**

- A. See Section 312316 - Excavation and Section 312323 - Fill for additional requirements.
- B. Backfill around sides and to top of pipe with cover fill, tamp in place and compact, then complete backfilling.

#### **3.02 INSTALLATION**

- A. Install pipe, fittings, and accessories in accordance with manufacturer's instructions. Seal watertight.
  - 1. Plastic Pipe: Also comply with ASTM D2321.
- B. Lay pipe to slope gradients noted on layout drawings; with maximum variation from true slope of 1/8 inch (3 mm) in 10 feet (3 m).
- C. Connect to building storm drainage system, foundation drainage system, and utility/municipal system.

**END OF SECTION**